



VAN'S AIRCRAFT
TOTAL PERFORMANCE

RV-12 **MAINTENANCE MANUAL**



Aircraft Serial Number: _____

REVISION SUMMARY

CHAPTER	REVISION	DATE
COVER PAGE	9.4	09/29/19
ii	9.4	09/29/19
iii	7	09/29/19
iv-viii	7	12/18/18
1	9	09/29/19
2	1	04/16/10
3	6	09/29/19
4	3	12/18/18
5	6	12/18/18
6	4	07/16/16
7	2	04/03/14
8	5	12/18/18
9	6	12/18/18
10	1	04/16/10
11	4	07/16/16
12	5	07/16/16
13	5	04/03/14
14	3	09/29/19
15	1	04/16/10
16	1	04/16/10
17	4	12/18/18
18	9	09/29/19
19	3	07/16/16
20	4	12/18/18

OWNER/OPERATOR RESPONSIBILITIES

For continued airworthiness of an RV-12 aircraft, the owner/operator must comply with the following requirements as dictated in ASTM F 2295 Section 5.

- ❑ **Each owner/operator of an RV-12 shall read and comply with the maintenance manual and continued airworthiness information and instructions provided by Van's Aircraft Inc.**
- ❑ **Each owner/operator of an RV-12 shall provide Van's Aircraft Inc. with up to date contact information so that Van's Aircraft may send the owner/operator supplemental notification bulletins.**

Van's Aircraft, Inc.
14401 Keil Road, NE
Aurora, OR 97002 USA

Phone: 503.678.6545 Fax: 503.678.6560
Website: www.vansaircraft.com
email: orders@vansaircraft.com

- ❑ **The owner/operator of an RV-12 shall notify Van's Aircraft Inc. of any safety of flight issue or significant service difficulty upon discovery using the Feedback Form provided in the Maintenance Manual.**
- ❑ **The owner/operator of an RV-12 shall comply with all Van's Aircraft Inc. issued notices of corrective action and comply with all applicable aviation authority regulations in regard to maintaining the airworthiness of the LSA. Notices of corrective action are published on the Van's Aircraft web site RV-12 Service Information Page. Or go to <http://www.vansaircraft.com/public/service-rv12.htm>**
- ❑ **An owner of an RV-12 shall ensure that any needed corrective action be completed as specified in a notice, or by the next scheduled annual inspection.**
- ❑ **Should an owner/operator not comply with any mandatory service requirement the RV-12 shall be considered not in compliance with applicable ASTM standards and may be subject to regulatory action by the presiding aviation authority.**
- ❑ **The owner/operator may submit written comments and questions regarding any mandatory Notice to the organization who issued the Notice.**

TABLE OF CONTENTS

CHAPTER 1- GENERAL

INTRODUCTION	1-1
Purpose.....	1-1
Summary.....	1-1
Scope	1-2
Replacement Parts.....	1-3
Method	1-3
APPLICABLE THROUGHOUT	1-4
General Safety	1-4
Safety of Flight Reporting Procedure	1-5
Helpful Terminology	1-5
Abbreviations	1-6
Units.....	1-7
TOOLS AND EXPENDABLES	1-8
ENGINE.....	1-12
LUBRICATIONS AND CAPACITIES	1-13
Engine Oil.....	1-13
Brake Fluid	1-13
Engine Coolant.....	1-14
Fuel	1-14
Tire Pressures.....	1-14
Torque Values.....	1-15
GENERAL PROCEDURES.....	1-16
Lifting & Supporting the fuselage	1-16
WEIGHT AND BALANCE	1-18
EQUIPMENT LIST	1-21

CHAPTER 2- SERVICE SCHEDULE

OVERVIEW	2-1
----------------	-----

CHAPTER 3- INSPECTION.....

OVERVIEW	3-1
INSPECTION DESCRIPTION	3-3
Pre-inspection / Post-inspection.....	3-3
Cockpit	3-5
Radio.....	3-7
Optional Equipment.....	3-7
Emergency Locator Transmitter	3-7
Propeller.....	3-7

Engine	3-8
Firewall Forward.....	3-8
Fuselage	3-10
Landing Gear	3-11
Wing / Center Section/AOA	3-12
Rear Spar Doubler	3-13
Empennage.....	3-14
Angle-Of-Attack System.....	3-17
Paperwork.....	3-17
CHAPTER 4 - STRUCTURAL REPAIRS	4-1
OVERVIEW	4-1
MINIMUM CERTIFICATION.....	4-2
CHAPTER 5 - STRUCTURES	5-1
OVERVIEW	5-2
FUSELAGE.....	5-2
WING AND FLAPERON	5-4
EMPENNAGE.....	5-6
LANDING GEAR.....	5-8
FAIRINGS - WHEEL AND GEAR LEG.....	5-10
SERVICE	5-12
CHAPTER 6 - FLIGHT CONTROLS.....	6-1
OVERVIEW	6-2
SERVICE	6-3
CHAPTER 7 - BRAKE SYSTEM	7-1
OVERVIEW	7-2
SERVICE	7-2
CHAPTER 8 - ELECTRICAL SYSTEM	8-1
OVERVIEW	8-2
SERVICE	8-4
CHAPTER 9 - INSTRUMENTS & AVIONICS.....	9-1
OVERVIEW	9-2
PITOT & STATIC.....	9-3
SERVICE	9-4

CHAPTER 10 - UTILITY SYSTEMS	10-1
OVERVIEW	10-2
HEAT	10-2
VENTILATION	10-3
SERVICE	10-4
CHAPTER 11 - PROPELLER	11-1
OVERVIEW	11-2
SERVICE	11-2
Prop & Hub.....	11-3
CHAPTER 12 - FIREWALL FORWARD	12-1
OVERVIEW	12-2
Engine	12-3
SERVICE	12-3
CHAPTER 13 - FUEL SYSTEM	13-1
OVERVIEW	13-2
Fuel System Schematic.....	13-3
SERVICE	13-3
CHAPTER 14 - EXHAUST SYSTEM	14-1
OVERVIEW	14-2
SERVICE	14-4
CHAPTER 15 - PAINTING AND COATINGS	15-1
OVERVIEW	15-2
SERVICE	15-3
CHAPTER 16 - TROUBLESHOOTING	16-1
CHAPTER 17 - FEEDBACK & REPLACEMENT PARTS	17-1
REPORTING METHODS	17-1
REPLACEMENT PARTS.....	17-2
SUBSTITUTE PARTS	17-3
CHAPTER 18 - SUPPLEMENT	18-1
SERVICE SCHEDULE.....	18-3
INSPECTION CHECKLIST	18-7
3-VIEW	18-25
FEEDBACK FORM.....	18-27

CHAPTER 19 - GLOSSARY 19-1

CHAPTER 20 - INDEX..... 20-1

**NOTE: Pages 1-21 and 1-22 correspond to a particular EFIS installation.
Please remove all pages that do not correspond to your EFIS.
Specific EFIS type is noted next to the page number.**

TABLE OF ILLUSTRATIONS

Figure 1: Tools	1-9
Figure 2: Oil Viscosity.....	1-13
Figure 3: Lifting and supporting	1-17
Figure 4: Remove for inspection	3-4
Figure 5: Control Stops	3-6
Figure 6: Rivet Inspection.....	3-10
Figure 7: Wing Retention Pin Bushing.....	3-13
Figure 7.1: Inspect Rear Spar Doubler.....	3-14
Figure 8: Rudder Stop	3-15
Figure 9: Fuselage	5-3
Figure 10: Wing and Flaperon.....	5-4
Figure 11: Empennage.....	5-6
Figure 12: Landing Gear	5-8
Figure 13: Nose Wheel and Gear Leg Fairings	5-10
Figure 14: Main Wheel Fairings	5-11
Figure 15: Flaperon hinge	5-18
Figure 16: Extracting the DW4K2X bearing.....	5-20
Figure 16.1: Rear Spar Doubler Replacement	5-24
Figure 17: Locking clip removal.....	6-4
Figure 18: Tensioner barrel removal	6-4
Figure 19: Torque tube lubrication	7-4
Figure 20: Optional Wing Tip Lighting	8-3
Figure 21: Fuse panel	8-6
Figure 22: Trim/Servo assembly removal.....	8-8
Figure 23: Pitch-trim servo removal.....	8-8
Figure 24: Stall warning ground	8-10
Figure 25: Snap Bushing.....	8-13
Figure 26: Rotax 912ULS.....	12-3
Figure 27: Carburetor Overview	12-8
Figure 28: Mixture Screw	12-9
Figure 29: Throttle Handle Idle Position	12-10
Figure 30: Vacuum Gauge	12-11
Figure 31: Fuel Pressure Hose Flush.....	13-9

CHAPTER 1 - GENERAL

INTRODUCTION

PURPOSE

The purpose of this manual is to provide guidance to RV-12 owners, pilots, mechanics, regulatory officials, and aircraft/component manufacturers that are certified to perform maintenance, repairs, and alterations on the light sport aircraft covered in this manual.

SUMMARY

This manual contains maintenance instructions for the RV-12 light sport aircraft. The RV-12 is a single engine, fixed tricycle gear, full-cantilever monoplane. The two-seat cockpit is enclosed with a tip-up windscreen/canopy. The occupants sit side-by-side, aft of the engine and forward of the wing spar. Both of the wings are quick removable. The flaperons remain with the wings and self-connect to the control linkage when the wings are installed. The empennage consists of a vertical stabilizer, rudder and stabilator with anti-servo/trim tab.

The airframe is a semi-monocoque aluminum structure, with some steel and fiberglass parts. Fiberglass composite parts are used to finish some non-structural portions of the aircraft.

The pilot and passenger board the aircraft from either side using the boarding step and a reinforced area near the leading edge of the wing. The pilot is seated on the left side (from within the cockpit) of the aircraft. A combination Electronic Flight Information System (EFIS) and Engine monitoring System (EMS) with graphical user interface is used to monitor and report flight and engine performance information to the pilot.

The Rotax 912ULS 100 hp four cylinder engine is enclosed in a fiberglass composite cowling at the front of the aircraft. Engine power is transferred via an integral gearbox to the Sensenich composite propeller.

The pilot and the passenger both have full flight and ground controls. Pitch and roll is controlled from either control stick. The control sticks are linked by push/pull rods and torque tubes to the flaperons, and linked by cables to a stabilator. The flap lever controls the flap function of the flaperons. Yaw is controlled using rudder pedals linked by cables to a traditional rudder that is hinged to a fixed vertical stabilizer. The rudder pedals have integrated left and right foot pedals that are used to independently control the wheel brake on the corresponding side.

SCOPE

• **NOTE: This maintenance manual is intended to be used in conjunction with the RV-12 Kit Assembly Instructions (KAI) when completing maintenance or repair processes.**

All of the service and maintenance requirements that are unique to the RV-12 S-LSA are included in this manual. The general service and maintenance duties that are common to standard aircraft still apply to the RV-12 regardless of the inclusion of those requirements in this manual. All inspection and maintenance and all maintenance log entries must be made in accordance with 14 CFR / FAR's.

The manufacturers of third party components provide manuals that include complete service and maintenance requirements that are specific to these components. The current service and maintenance manuals from any third party manufacturer, such as; engine, propeller, avionics, etc. always take precedence over the related content in this manual. There are references to third party documentation in this manual, as well as some supplementary information which is **for convenience only**. It is recommended to refer directly to the manufacturer's service manuals for complete service information that is unique to applicable components.

The manufacturers that provide operating and/or maintenance manuals to use in conjunction with this manual are as follows:

- ◆ Rotax – engine
- ◆ Sensenich – propeller
- ◆ Matco – wheels and brakes
- ◆ Dynon – EFIS / EMS
- ◆ Garmin – EFIS / EMS, GPS and Nav/comm
- ◆ TCW – Backup Battery
- ◆ FlightCom – intercom
- ◆ ACK – ELT
- ◆ Artex – ELT
- ◆ Odyssey – battery
- ◆ Van's Aircraft – RV-12 Kit Assembly Instructions (KAI).

The service and inspection portions of this manual indicate the minimum certification requirements for a person doing maintenance or repairs on the RV-12. Certification requirements for service and maintenance may vary around the world. It is essential to determine the correct and legal maintenance and certification requirements applicable to the area that the airplane is registered. The documents necessary to determine these requirements for S-LSA in the United States are as follows:

- ◆ RV-12 Maintenance Manual
- ◆ RV-12 Kit Assembly Instructions
- ◆ Federal Aviation Regulations for Light Sport Aircraft Maintenance Technicians
- ◆ Aircraft Inspection, Repair, and Alterations, AC 43.13.

REPLACEMENT PARTS

The RV-12 KAI is the primary reference for replacement part information. Section Four in the KAI is a directory of all part numbers with reference information of where to find it within the main KAI manual. The documentation produced by third party parts manufacturers (listed above) should be used as the primary reference for part information for those components.

METHOD

The pages throughout this maintenance manual are numbered at the bottom with the chapter number followed by a dash and the page number of the applicable chapter. There are many cross-references in this manual. Cross-references within this manual are made using the page numbers, unless otherwise specified. Following is an example of a typical cross-reference to additional information within this manual. *Example: When there is additional information that is related to this sentence the cross-reference to that page will be in parenthesis following the period. (1-2)*

Chapter 1 will introduce general information that is helpful for using this manual. General information includes manual introduction, general safety information, notification methods, abbreviations, collective tool list, list of expendables, lubrication and capacities and general procedures.

Chapter 2 introduces the *service schedule checklist*.

Chapter 3 provides an explanation of the annual/100 hour *inspection checklist* including illustrations that clarify some checkpoints of the aircraft. Read Chapter 1–3 prior to performing the inspection, and use it as a reference during the inspection.

Chapter 4 and following begin with an illustration of the subject discussed, an 'Overview' of the chapter content and a list of 'Components'. The 'Service' section, where applicable, begins with a table of 'Supplies', which includes; 'Tools', 'Expendable' and 'Replaceable' parts. The service section provides instructions for 'General' removal, replacement and installation that are acceptable for the owner or operator to perform. The service section also includes instructions for 'Service Schedule Procedures' which correspond to the items on the 'Service Schedule Checklist'. Each service section task includes a table that summarizes the properties of the task.

The task summary table lists the Tools, Expendable, and replaceable items that are task specific. Only tools specific to the immediate task will be listed. In cases that another task must be done to complete the immediate task, the tools needed for the other task will be given in the instructions that correspond to that task. Some recommended tools will require other tools to be effective; for example: sockets will require a ratchet; drill bits will require a drill. Unless otherwise specified the driving tool is implied rather than listed. The table also includes the 'Service Rating' applicable to the task, the 'Minimum Certification' required to perform the task legally, and 'Additional References' that may be helpful or necessary to complete the task. Each hardware item to be removed in the service instructions will be followed by the quantity (if greater than one) in parenthesis. *For example, an instruction step that requires the removal of one*

bolt, six washers and two nuts will appear as follows: 1. Remove the bolt, washers (6), and nuts (2).

Chapter 16 offers direction for solving potential problems that may puzzle the owner of any aircraft.

Chapter 17 provides instructions for reporting the discovery of anomalies that could compromise the airworthiness of the aircraft.

Chapter 18 includes the *inspection checklist, service schedule checklist* and other helpful documents.

APPLICABLE THROUGHOUT

GENERAL SAFETY

Safety must be considered the first priority when performing maintenance or service on an aircraft or part. The content in this manual is only for use in a safe work environment with all necessary safety equipment readily available and in use when applicable.

Maintenance or repair classified in this manual as owner and SPC and in 14 CFR, FAR 43 Appendix 'A' can be done by an RV-12 owner or operator that possesses a Sport Pilot certificate or higher.

An LSA repairman certificate with a maintenance rating or an FAA issued A&P certificate are the minimum level of certification to perform line maintenance or repairs and the annual condition inspection on an RV-12.

Prior to performing maintenance or repair always disconnect the negative (-) battery cable from the battery.

The strength of an airframe designed using semi-monocoque construction relies on both the skins and the skeleton for complete structural strength. If a skin has been damaged, typically the underlying structure has also been damaged. Carefully inspect any damage to assess the extent of the damage. If the damage is localized to just outer skins, they can be removed and replaced. If inspection indicates that the substructure is also damaged the aircraft manufacturer must be consulted for further assessment.

Every time hardware is removed it must be checked for signs of wear or fatigue. Inspect the head, shank, and threads of bolts, and the edges and threads of nuts. Locking hardware may only be used for one term of service. Safety wire, cotter pins, lock washers and similar hardware are only reliable after one term of service. It is permissible to reuse nylock and all steel style self-locking nuts if it is determined that the self-locking feature has not been degraded. **Always replace questionable hardware.**

Operation in Extreme Conditions: Exposure to extreme climatic conditions, including dust, salt, debris, bugs, will warrant frequent inspections of air filters, coolant radiator, and oil cooler as defined in the Rotax maintenance manual. Frequent exposure to extreme conditions or altitudes demands adjustment of the carburetor and cooling system. Contact an authorized Rotax distributor for consultation.

SAFETY OF FLIGHT REPORTING PROCEDURE

To maintain the highest level of safety and as dictated in ASTM F 2295 Section 5, the FAA requires, and Van's Aircraft Inc. requests notification of any safety of flight issue, or service or maintenance difficulties that could compromise the airworthiness of the RV-12 aircraft. **A feedback form is provided in the Supplement section of this manual. Refer to Chapter 17 for a description of a valuable report and the different reporting methods available.**

HELPFUL TERMINOLOGY

▲ *WARNING: INDICATES AN ACTION NECESSARY TO PREVENT INJURY OR DEATH.*

■ *CAUTION: INDICATES AN ACTION NECESSARY TO PREVENT DAMAGE TO PARTS OR PROPERTY.*

● *NOTE: PROVIDES VALUABLE ADDITIONAL INFORMATION.*

The Glossary provides definitions to many of the terms used throughout this manual.

ABBREVIATIONS

A&P*	Airframe and Power-plant Mechanic	Kph	Kilometers per hour
AKI	Anti-knock index (octane rating)	Kts	Knots
API	American Petroleum Institute	lb	U.S. pound
AST*	Anti-servo/trim tab	LL	Low-Lead
AVGAS	Aviation Gasoline	LSA	Light Sport Aircraft
C	Celsius	LSA-RM*	Light Sport Aircraft – Repairman Maintenance rating
CG	Center of Gravity	ltr	Liter
CHT	Cylinder Head Temperature	m	meter
cm	Centimeter	Max	Maximum
CST*	Category specific training	mb	millibar
EFIS*	Electronic Flight Information System	mi	Statute mile
EGT	Exhaust Gas Temperature	Min	Minimum
ELT*	Emergency Locating Transmitter	ml	Milliliters
EMS	Engine Monitoring System	mm	Millimeter
F	Fahrenheit	mph	miles per hour
FAA	United States Federal Aviation Administration	naut mi	Nautical miles
FAR's	Federal Aviation Regulations	Nm	Newton meters
fl. oz.	fluid ounce (U.S.)	OAT	Outside Air Temperature
ft	Feet	oz	Ounce
ft/lbs	Foot-Pounds	POH*	Pilot Operating Handbook
FWD	Forward	psi	Pounds per Square Inch
gal	Gallon	pt	Pint (U.S.)
GPS*	Global Positioning System	RON	Research Octane Test
HP	Horse Power	RPM	Revolutions Per Minute
ID	Inner Diameter	S-LSA*	Special Light Sport Aircraft
in	Inch (depending on context)	S/N	Serial Number
in ²	Square inches	SAE	Society of Automotive Engineers
in/lb	Inch-Pound	SPC*	Sport Pilot Certified
KAI*	Kit Assembly Instructions	TT	Total Time
kg	kilogram	VDC	Voltage, Direct Current
kPa	Kilopascal		
* -- See glossary for definition			

UNITS:

Speed:				
1 mph	=	1.64 kph	=	0.869 kts
Distances:				
		1 in	=	2.54 cm
1 ft	=	12 in	=	0.305 m
1 mi	=	5,280 ft	=	1.61 km
1 naut mi	=	1.15 mi	=	1.85 km
Mass:				
		1 oz	=	28.3 grams
1 lb	=	16 oz	=	0.454 kg
Pressure:				
		1 psi	=	6.895 kPa
		1 mb	=	0.1 kPa
Volume:				
1.8 cubic in	=	1 fl. oz	=	29.57 ml
1 quart	=	2 pints	=	32 fl. oz
1 gal	=	8 pints	=	3.79 ltr
Torque:				
	=	1 in/lb	=	0.113 Nm
1 ft/lb	=	12 in/lb	=	1.356 Nm
Temperature:				
(F-32)/1.8	=	(1.8 x C)+32		

TOOLS AND EXPENDABLES

There are many aircraft tool suppliers available. An Internet search can be conducted to determine which supplier can provide the necessary tools

• **NOTE: THIS TOOL LIST DOES NOT INCLUDE ALL OF THE TOOLS SUGGESTED FOR THE INSPECTION PROCEDURES.**

TOOLS

<ul style="list-style-type: none"> ◆ Combination wrenches: <ul style="list-style-type: none"> ▪ 1/4 ▪ 5/16 ▪ 11/32 ▪ 3/8 ▪ 7/16 (2) ▪ 1/2 ▪ 9/16 ▪ 11/16 ▪ 1 1/2 ◆ Ratchet ◆ Sockets: <ul style="list-style-type: none"> ▪ 5/16 ▪ 11/32 ▪ 3/8 ▪ 7/16 ▪ 1/2 ▪ 9/16 ▪ 3/4 ▪ 1 1/2 ▪ 10 mm ▪ 11 mm ▪ 13 mm 	<ul style="list-style-type: none"> ◆ Allen wrenches: <ul style="list-style-type: none"> ▪ 3/16 ▪ 1/4 ▪ 5/16 ▪ 4mm ▪ 5mm ▪ 6mm ▪ 8mm ◆ Torque wrench (in/lbs & ft/lbs) ◆ 5/8 or 16 mm spark plug socket ◆ Screwdrivers: <ul style="list-style-type: none"> ▪ #2 Phillips ▪ #3 Phillips ▪ 3/16 Flat Blade ◆ Power-drill ◆ #30 drill bit ◆ Blind rivet tool ◆ Straight edge ◆ Razor knife ◆ Flashlight ◆ Step ladder ◆ Wire cutters ◆ Battery charger ◆ Multi-meter ◆ Syringes 	<ul style="list-style-type: none"> ◆ Wooden dowels 1/2 - 1 inch dia. and 1 1/2 - 1 3/4 in. dia. ◆ Oil Filter wrench ◆ Oil Filter cutter and mallet ◆ Two 25 in. padded stands each rated to support a minimum of 500 pounds ◆ Container (various sizes, suitable for petroleum) ◆ 24-inch length of 1/2-inch I.D. fuel hose ◆ Scouring pad or equivalent ◆ Sandpaper (various grades) ◆ Spark plug gap tool (wire type) ◆ Compression tester ◆ Magnifying Glass ◆ Small square ◆ Tire air pressure gauge ◆ Needle nose pliers ◆ 5-inch "C" clamp ◆ Terminal crimping tool ◆ Locking (vice grip style) pliers ◆ 2 1/2 x 3/16 bolt, washer, nut ◆ Vacuum gauge set ◆ Portable weight scale (tension type) ◆ Fire extinguisher ◆ Pump style oil can with hose ◆ Safety wire twisting pliers
--	--	---

• **NOTE: TOOLS DIFFER IN SIZE AND CONFIGURATION. THE FOLLOWING ILLUSTRATIONS ARE ONLY EXAMPLES OF WHAT A TOOL MAY LOOK LIKE.**

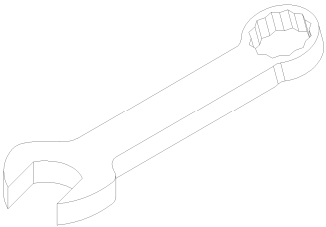
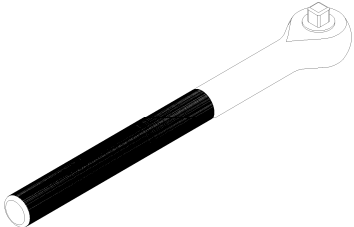
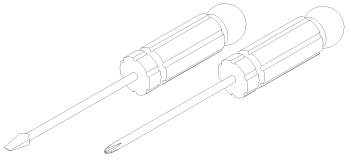


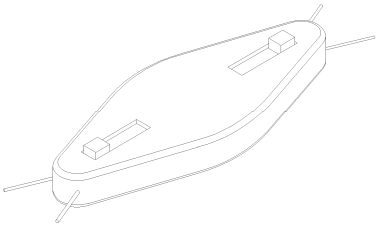
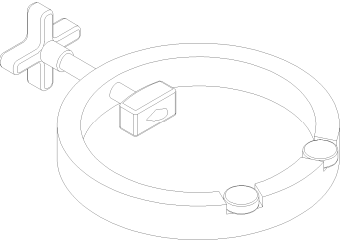
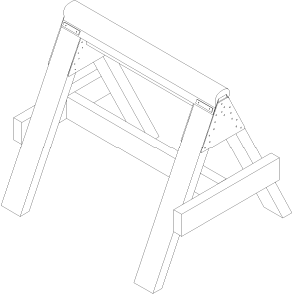
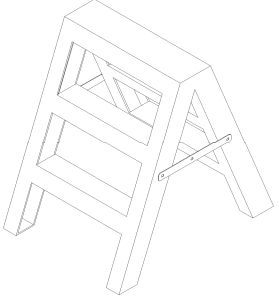
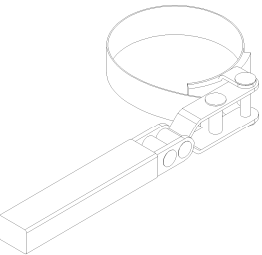
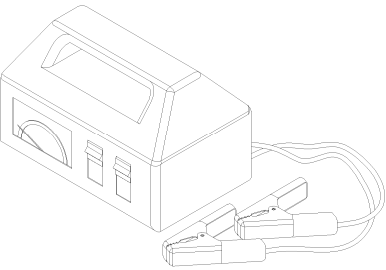
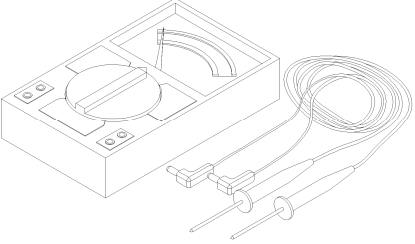
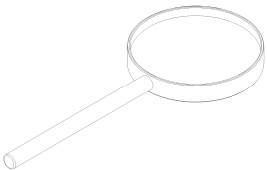
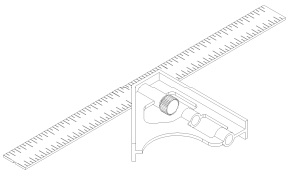
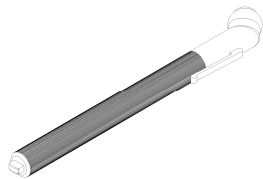
 <p>Combination Wrenches</p>	 <p>Ratchet</p>	 <p>Screwdrivers</p>
 <p>Sockets</p>	 <p>Allen Wrenches</p>	 <p>Gap Gauge</p>
 <p>Oil Filter Cutter</p>	 <p>Heavy Stands</p>	 <p>Step Ladder</p>
 <p>Oil Filter Wrench</p>	 <p>Battery Charger</p>	 <p>Multi-meter</p>
 <p>Magnifying Glass</p>	 <p>Square</p>	 <p>Air Pressure Gauge</p>

Figure 1

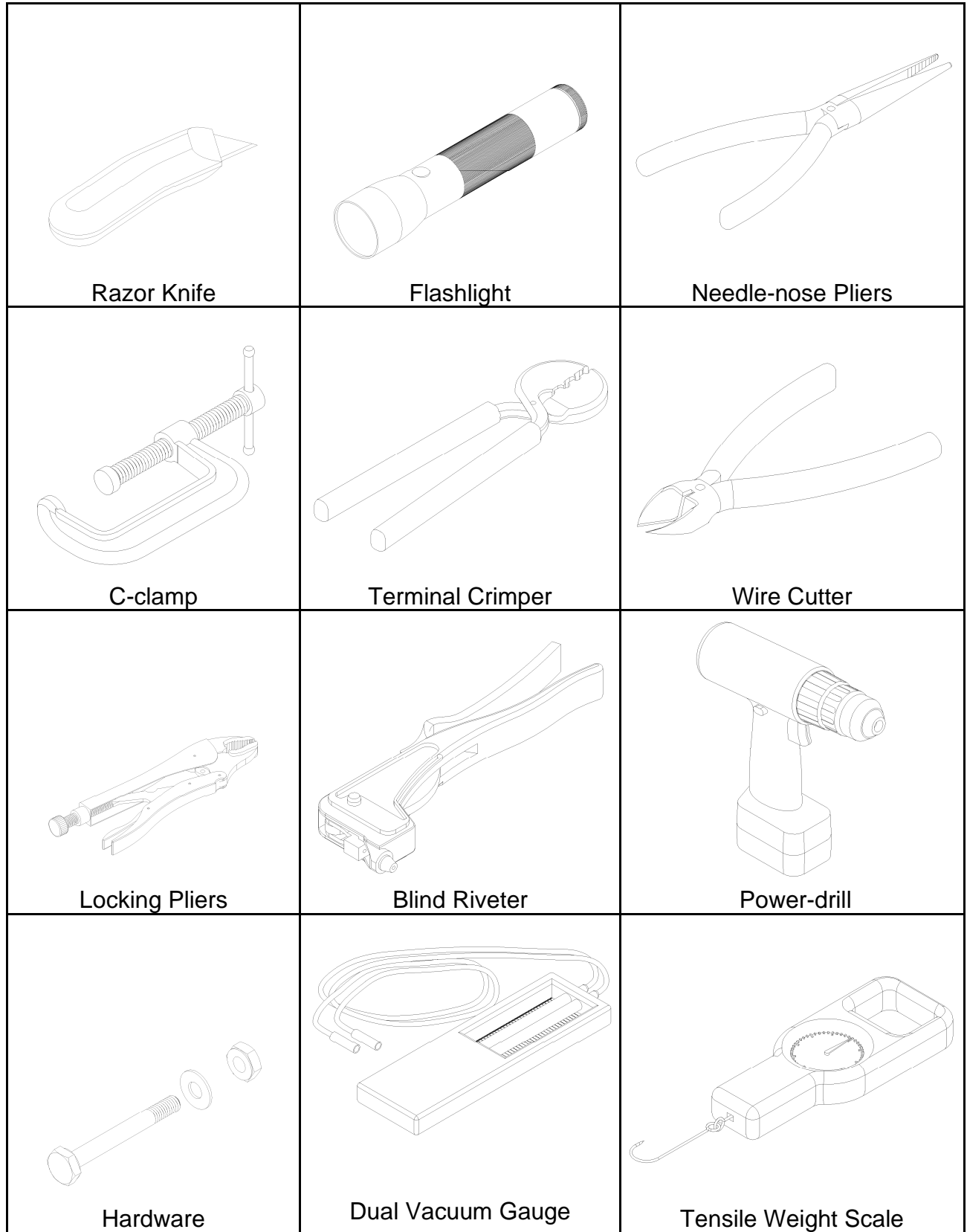


Figure 1

■ **CAUTION: REPLACEMENT PARTS MUST BE OF EQUIVALENT SIZE, TYPE AND RATING AS THE ORIGINAL PARTS FROM THE MANUFACTURER.**

EXPENDABLE

PARTS	PART NUMBER
Oil filter	Rotax 825 701
Copper crush ring (for drain plug)	Rotax 250010
Gas-5 O-ring gasket	GASKET GAS-345
Tire	U-5:00X5 Tire (any aircraft grade 5:00X5, 4 or 6 ply tire is acceptable).
Inner tube	U 5:00X5-6IT (any aircraft grade 5:00X5-6 inner tube is acceptable)
Brake shoe linings	M66-106 (or equivalent)
Fuses	ATO/ATC ¼ " blade style 1, 2, 3, 5, 7.5, 30 Amp rating. All fuse values of 3 amp and higher are required to have LED "blown fuse" indicators.
LUBRICANTS	RECOMMENDATION OR EQUIVALENT
Engine oil	As specified in latest Rotax documentation
Spray lubricant	LPS2 or Tri-Flow
Dry lubricant (candle wax, etc.)	TOOL BOELUBE PASTE
Wheel bearing grease	Aeroshell 22 or equivalent
Thread-lube	Loctite 567 or equivalent
Anti-seize compound, High temp	Loctite Anti-Seize or equivalent
Hydraulic fluid	MIL-H-5606A or MIL- PRF-83282
Air filter oil	EA K&N 99-5050 KIT
MISCELLANEOUS	RECOMMENDATION OR EQUIVALENT
Engine coolant	1:1 Water/Ethylene Glycol (refer to Rotax engine documentation)
Safety wire	WIRE SAFETY .032
Fuel tank sealant	MC-236-B1/2 or MC-236-B2
Plexus Cleaner/Polish	CA CANOPY CLEANER
Cotter pins	MS24665-xyz
Plastic tie wraps	Non-specific
Wire terminals	Male & Female spade, splice, and ring
Blind rivets	LP4-3 (unless otherwise specified)
Grey touch-up paint	PAINT, TOUCHUP PGRAY Cardinal gray #3607-GR-230
Primer	Any protective primer suitable for use on aluminum and/or steel as appropriate
Decorative touch-up paint	From paint process

ENGINE

- **NOTE: THE ENGINE SPECIFICATION INFORMATION IS REFERENCED FROM THE ROTAX 912 SERIES, OPERATOR'S MANUAL, OM REV.4.**

SUMMARY

Make	Rotax 912 ULS
Displacement	1352 cc
Ignition	Ducati Double CDI
Carburetor	Bing
Rated Horsepower	100 Hp @ 5800 RPM

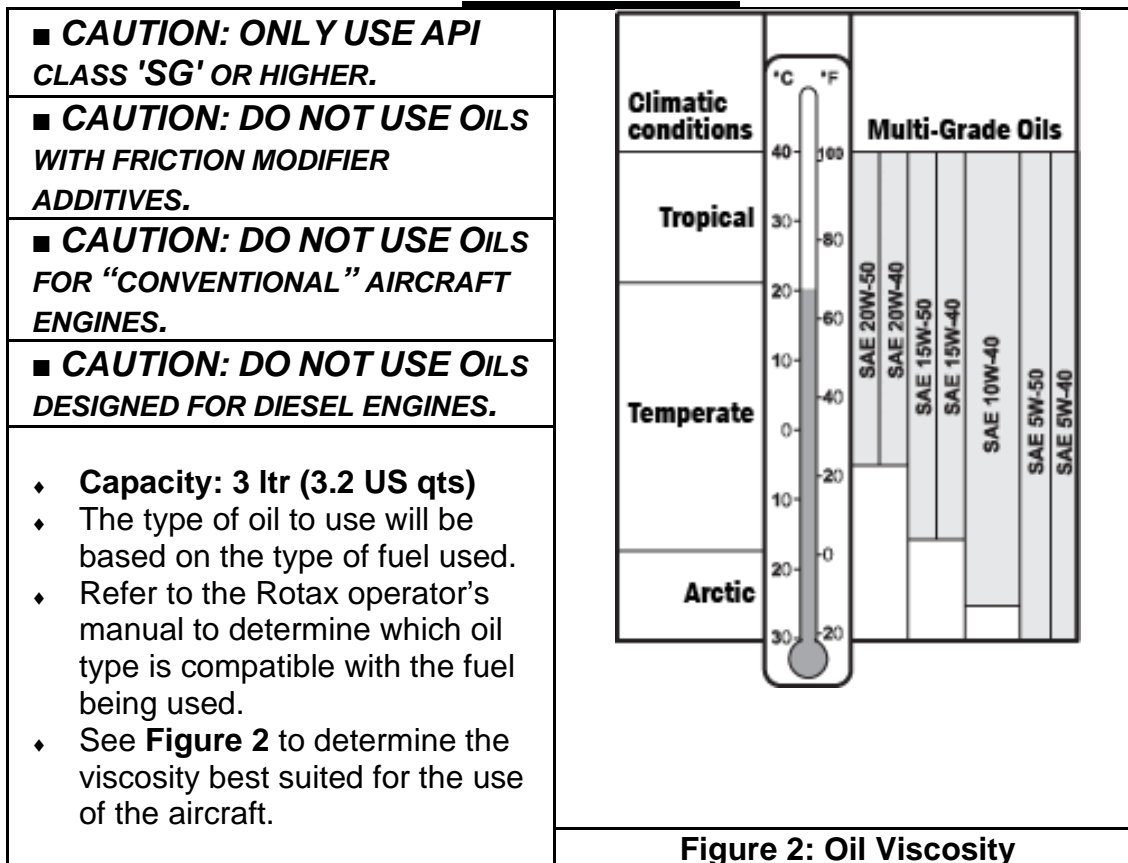
DESCRIPTION

The LSA covered by this manual will have a Rotax 912ULS power plant. The power plant is an over-head valve four-stroke, horizontally opposed four-cylinder. The cylinder heads are liquid cooled. The cylinder barrels are air-cooled. Dual constant depression carburetors regulate the air/fuel mixture. The dual breaker-less, capacitor discharge ignition system provides the electrical energy to the spark plugs.

For engine maintenance requirements and procedures refer to the Rotax Engine Type 912 Series line maintenance and heavy maintenance manuals.

LUBRICATION AND CAPACITIES

ENGINE OIL



BRAKE FLUID

▲ **WARNING: NEVER USE AUTOMOTIVE BRAKE FLUID.**

Use Mil Spec 5606A or MIL-PRF-83282

Brake fluid draining, flushing, and replacing instructions Page 7-5.

CAPACITY:

15.4 fl. oz. (US) (.455 liters)

ENGINE COOLANT

SUITABLE COOLANTS

COOLANT MIX:

50% ethylene glycol concentrate with anticorrosion additives designed for aluminum without sulfates and phosphates,

50% distilled or de-mineralized water.

See the latest version of the Rotax Operators Manual and SI 912-016 for further information on coolant types and limitations.

CAPACITY:

0.6 gallon (US) (2.3 liters)

Fill expansion tank to between the 'min' and 'max' marks in the overflow bottle.

MINIMUM:

Expansion tank 2/3 full + .2 liter (.4 liq pt) in overflow bottle

FUEL

SUITABLE FUEL

91 AKI (premium unleaded automotive)

100 LL Aviation Fuel

See the latest version of the Rotax Operators Manual and SI 912-016 to determine other approved fuel types, limitations and maintenance considerations.

CAPACITY:

19.8 US Gallons (75.0 liters)

TIRE PRESSURES

NOSE TIRE - 22 psi (23 psi maximum)

MAIN TIRES - 25 psi (28 psi maximum)

TORQUE VALUES

Torque applied is for the size of the bolt shank not the wrench size. On smaller bolts use a torque wrench calibrated in inch pounds, not foot pounds.

When tightening fasteners with self-locking nuts the chart values must be modified. The friction drag torque must be determined and then added to the standard torque from the table. Due to the friction of the locking device noticeable torque is required just to turn the nut onto the threads and does nothing to actually tighten the parts together and stretch the bolt (clamp load). This is called friction drag (or prevailing) torque. Run the nut down to where it nearly contacts the washer or bearing surface and check the friction drag torque required to turn the nut. (At least one thread should protrude from the nut). Add the friction drag torque to the standard torque. This sum is referred to as the final (or total) torque, which should register on the indicator or setting for a snap-over type torque wrench.

The propeller manufacturer and the engine manufacturer have specific torque requirements for their equipment. Consult the appropriate manual for that information.

	ft-lb	in-lb	N-m
Oil Tank Drain Screw	18	220	25
Oil Filter	Contact + 3/4 Turn or as Specified		
Magnetic Plug	18	220	25
Water Pump Drain Screw	8	90	10
Carburetor Socket Screws	11	135	15
Spark Plugs 16mm	15	180	20
Exhaust Nuts	9	106	12

AN Bolt size	Bolt size - Threads per inch	Standard nuts AN310, AN315, MS20365	
		Inch pounds	Foot Pounds
AN3	#10-32	20-25	1.6-2.0
AN4	1/4-20	50-70	4.2-5.8
AN5	5/16-24	100-140	8.3-11.6
AN6	3/8-24	160-190	13.3-15.8
AN7	7/16-20	450-500	37.5-41.7
AN8	1/2-20	480-690	40-57.5
AN9	9/16-18	800-1000	66.6-83.3
AN10	5/8-18	1100-1500	91.6-125

(Portions of this information has been adapted from AC 43. 13)

GENERAL PROCEDURES

TIRE REMOVAL	REFER TO 5-1
WING REMOVAL	
CANOPY REMOVAL	
COWL REMOVAL	REFER TO 12-1
OIL LEVEL CHECK	
FUEL SYSTEM DRAINING	REFER TO 13-1
GASCOLATOR SAMPLE	

LIFTING & SUPPORTING THE FUSELAGE

▲ **WARNING:** USE STURDY SUPPORT STANDS THAT ARE EACH CAPABLE OF SUPPORTING AT LEAST 500 POUNDS.

■ **CAUTION:** AVOID CONTACTING ANTENNA, FAIRINGS OR OTHER ACCESSORIES WHILE PLACING THE SUPPORT STANDS UNDER THE AIRCRAFT.

■ **CAUTION:** REMOVE OR ATTACH THE WINGS PRIOR TO LIFTING AND SUPPORTING THE AIRCRAFT.

When the aircraft is lifted, whether or not a jack is used, the method of support is the same. Obtain two sturdy, padded stands each capable of supporting **at least** 500 pounds. The padded contacting surface must be **at least** 1 1/2 inches wide. Two layers of 3/8 inch carpet are recommended. Both stands need to be about 30 inches long and 25 inches high.

LIFTING WITH A JACK

■ **CAUTION: USE APPROPRIATE JACK LOCATING FIXTURES TO ENSURE A STABLE JACKING SURFACE.**

■ **CAUTION: INSTALL A JACKPOINT WHEN LIFTING AT THE WING TIE-DOWN LOCATION.**

1. Place a jack as necessary to lift at the lower end of the nose gear-leg.
2. Lift the front of the aircraft enough to position a stand along the lateral rivet pattern, centered directly between the boarding steps.
3. Remove the jack.
4. Place the jack as necessary to lift on the tail tie-down.
5. Lift the tail of the aircraft enough to position a stand along the lateral rivet pattern centered directly beneath the rear wing-spar receptacles.
6. Remove the jack.
7. Test stability of the aircraft. Grab the tail tie-down and test for horizontal and vertical stability. Stabilize as necessary.

LIFTING WITHOUT A JACK

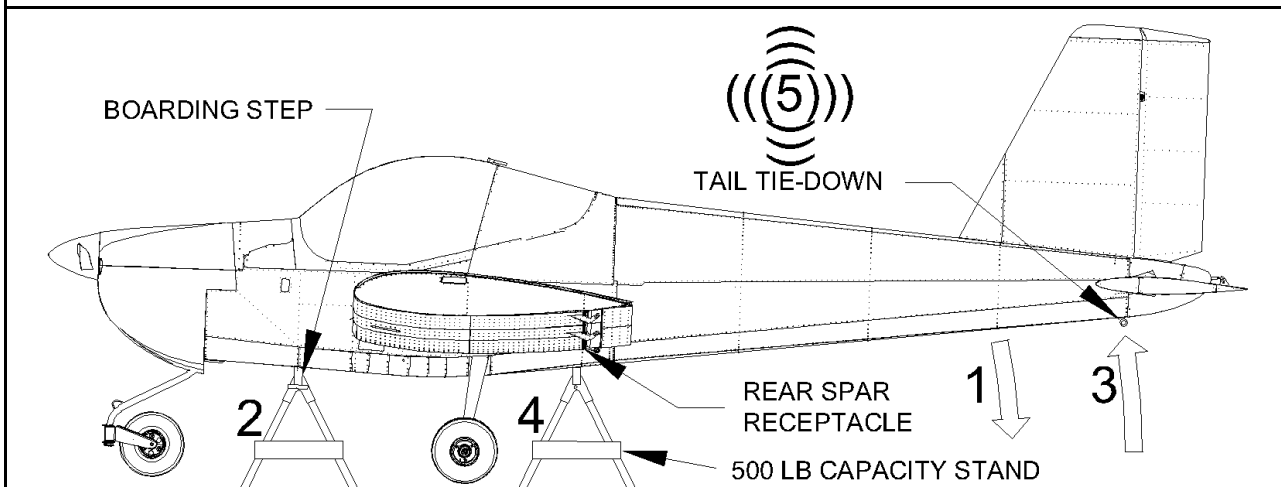


Figure 3: Lifting and supporting

● **NOTE: STEPS 1 THROUGH 5 CORRESPOND TO THE NUMBERS IN FIGURE 3.**

1. Raise the nose of the aircraft by lowering the tail.
2. Place a 25 inch stand along the lateral rivet pattern, centered directly between the boarding steps.
3. Lift the tail of the aircraft.
4. Place another 25 inch stand along the lateral rivet pattern centered directly beneath the rear wing-spar receptacles.
5. Check for horizontal and vertical stability. Stabilize as necessary.

WEIGHT AND BALANCE

It is the pilot's responsibility to insure that the aircraft is loaded properly and within the weight and balance limitations. The weight and balance of the aircraft are factors that will affect all flight performance, procedures and characteristics of the aircraft.

Find the actual licensed empty weight and CG of the aircraft on the Weight and Balance Form. This document is required to remain with the aircraft and must reflect any changes to the empty weight or CG. From that information and the instructions from the POH the pilot can determine the useful load and proper load distribution for the aircraft.

Weight and Balance Procedure

1. Make a copy of the RV-12 Weight & Balance Worksheet.
2. Install both lower and upper cowl.
3. Check that all fairings, access covers/plates etc are fully installed.
4. Place seat cushions in the aircraft, place the POH and fuel sample tube in the mapbox.
5. Check that there are no other items (tools, etc.) left in the cabin or map box.

6. Roll aircraft onto 2 inch (5cm) blocks under main wheels and chock wheels.
7. Level the canopy deck by inflating/deflating nose tire or main tires as appropriate or by increasing or decreasing block thickness.
8. Drop a plumb line off the leading edge of each wing just outboard of main wheel and mark a line on the floor between the two points.
9. Measure distance forward from left main wheel axle to the line on the floor and record on the RV-12 Weight & Balance Worksheet as D1.
10. Measure distance aft from nose wheel axle to line on floor and record on RV-12 Weight & Balance Worksheet as D2.
11. Measure distance forward from right main wheel axle to line on floor and record on RV-12 Weight & Balance Worksheet as D3.

12. Roll aircraft off blocks under main wheels. Place blocks on scale pads for main wheels. Zero scales.
13. Roll aircraft onto scales using ramps. Verify canopy deck is level (adjust tire inflation if/as necessary), close the canopy.
14. Record the left main wheel weight on RV-12 Weight & Balance Worksheet as W1.
15. Record the nose wheel weight on RV-12 Weight & Balance Worksheet as W2.
16. Record the right main wheel weight on RV-12 Weight & Balance Worksheet as W3.
17. On the RV-12 Weight & Balance Worksheet, calculate empty weight, empty moment, and empty arm.
18. Enter values for Empty Weight, Empty Moment, and Empty Arm into the table on "YOUR AIRPLANE" table within RV-12 Pilot Operating Handbook Section 6.
19. Place the RV-12 Weight & Balance Worksheet in the aircraft as it is part of the required documentation.
20. Enter values for Empty Weight, Empty Moment, and Empty Arm onto the Weight and Balance Record page in this section.

WEIGHT AND BALANCE RECORD

As of this date: ___/___/___ the following values represent current Weight and Balance Calculations.

Revised Empty Weight: _____ lb
Revised Empty Moment: _____ in-lb
Revised Empty Arm: _____ in

Signed: _____

As of this date: ___/___/___ the following values represent current Weight and Balance calculations resulting from the installation of the _____.

Revised Empty Weight: _____ lb
Revised Empty Moment: _____ in-lb
Revised Empty Arm: _____ in

Signed: _____

As of this date: ___/___/___ the following values represent current Weight and Balance calculations resulting from the installation of the _____.

Revised Empty Weight: _____ lb
Revised Empty Moment: _____ in-lb
Revised Empty Arm: _____ in

Signed: _____

As of this date: ___/___/___ the following values represent current Weight and Balance calculations resulting from the installation of the _____.

Revised Empty Weight: _____ lb
Revised Empty Moment: _____ in-lb
Revised Empty Arm: _____ in

Signed: _____

INSTALLED EQUIPMENT LIST

ITEM	WEIGHT Lbs.	ARM In.	INSTALLED	MOMENT In-lbs.
DYNON D-180		56.62		
GARMIN GTX 327		55.30		
GTX 327 TRAY		53.71		
GARMIN GTX 328		53.86		
GTX 328 TRAY		53.88		
GARMIN SL-40		53.76		
SL-40 TRAY		47.69		
GARMIN X95/6		58.08		
FLIGHTCOMFC 403		56.48		
ARTEX ME-406		96.18		
DYNON EDC-10A		147.73		
BATTERY		43.56		
TOTAL		-----		

THIS PAGE INTENTIONALLY LEFT BLANK

INSTALLED EQUIPMENT LIST

ITEM	WEIGHT Lbs.	ARM In.	INSTALLED	MOMENT In-lbs.
DYNON SV-HDX 1100	3.35	58.43		
DYNON (DUAL) SV-HDX 1100	3.35	58.43		
DYNON SV-EMS-220	.63	47.12		
DYNON SV-XPNDR-261	.77	47.66		
DYNON SV-BAT-320	.8	54.58		
DYNON SV-ADAHRS-200	.5	141.73		
DYNON SV-GPS-250	.44	43.13		
DYNON SV-GPS-2020	.44	43.13		
GARMIN GTR 200	2.37	54.13		
ACK 406	1.18	96.18		
BATTERY ODYSSEY PC-680	15.4	43.56		
DYNON SV-ADSB-472	.3	52.38		
DYNON SV AP PANEL	.3	57.78		
DYNON SV KNOB PANEL	.4	57.78		
TOTAL		-----		

INSTALLED EQUIPMENT LIST

ITEM	WEIGHT Lbs.	ARM In.	INSTALLED	MOMENT In-lbs.
DYNON AP SERVO PITCH	2	124.80		
DYNON AP SERVO ROLL	2	78.64		
TOTAL		-----		

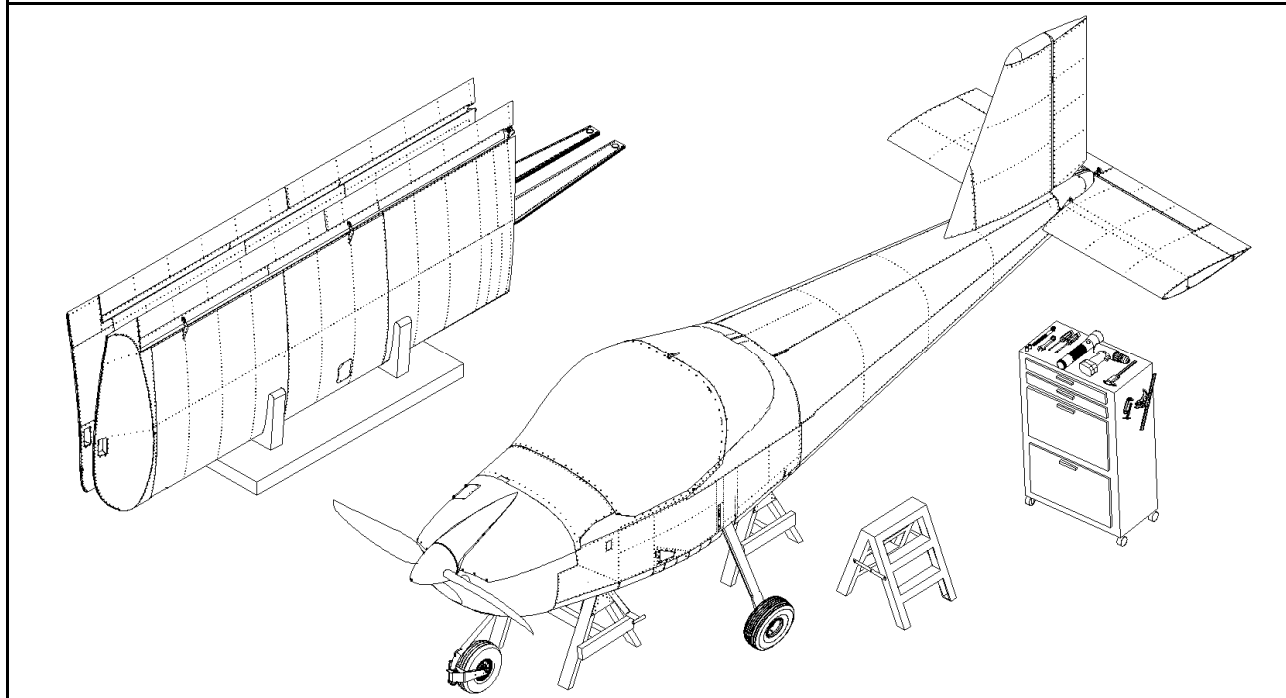
INSTALLED EQUIPMENT LIST

ITEM	WEIGHT Lbs.	ARM In.	INSTALLED	MOMENT In-lbs.
GARMIN GDU 460		57.90		
GARMIN GDU 465		57.90		
GARMIN GMC 305/307		57.57		
GARMIN GEA 24		47.12		
GARMIN GTX 23ES		50.93		
GARMIN GMU 22		141.73		
TCW IBBS-12V-3AH		50.73		
GARMIN GSU 25		118.76		
GARMIN GA 26C		43.13		
GARMIN GA 26XM		43.13		
GARMIN GTR 200		54.13		
ACK 406		96.18		
BATTERY		43.56		
GARMIN GA 36 OR GA 37		43.00		
GARMIN GPS 20A		47.57		
GARMIN GDL 39R				
GARMIN AUTOPILOT SERVOS				
TOTAL		-----		

INSTALLED EQUIPMENT LIST

ITEM	WEIGHT Lbs.	ARM In.	INSTALLED	MOMENT In-lbs.
GARMIN GTR225				
PS ENGINEERING PM3000-RV				
TOTAL		-----		

CHAPTER 2 - SERVICE SCHEDULE



OVERVIEW

Adherence to the service (or preventative maintenance) schedule is essential for maintaining airworthiness and maximizing aircraft longevity. There are specific requirements for who can perform preventative maintenance, line maintenance, or annual condition inspections on a LSA.

At least one of the following qualifications is necessary to perform **preventative maintenance** on an S-LSA RV-12:

- ◆ The owner or operator provided they are Sport Pilot certified or better.
- ◆ A person certified as “Repairman (light-sport aircraft)-Maintenance rating”
- ◆ An FAA certificated A&P mechanic.

At least one of the following qualifications is necessary to perform **line maintenance** on an S-LSA RV-12:

- ◆ A person certified as “Repairman (light-sport aircraft)-Maintenance rating”
- ◆ An FAA certificated A&P mechanic.

All Inspection and maintenance practices and all inspection and maintenance log entries must be made in accordance with pertinent FARs and the manufacturers' specified requirements.

● **NOTE: FOR THE SERVICE SCHEDULE CHECKLIST SEE SUPPLEMENT PAGE 18-3.**

The service schedule checklist serves as an index of the 'service procedures' section of each applicable chapter. The 'service procedure' section includes the recommended tools to complete each task. Applicable hardware will be stated using the most general terms. Refer to the original KAI for the specific hardware size, location, and configuration. Manufacturers of third party components determine service procedures for those components. The manual provided by the manufacturer for that component will provide service procedures. All component manuals are included with the aircraft at the time of purchase.

The 'What' column provides the name of the part or components to which the action applies. The 'Action' column will indicate what is necessary; replace, lubricate, clean, charge, etc. The 'When' column specifies the amount of time or use that may elapse before action is necessary. The 'How' column will direct you to the chapter or manual that includes the instructions, tools, supplies, and the level of certification required of the person performing the action, for the given action. Write the date of completion in the 'Service Date' column. Use the 'Initial' column to identify the person that performed the service.

CHAPTER 3 - INSPECTION

OVERVIEW.....	3-2
INSPECTION DESCRIPTION.....	3-3
Tools	3-3
Pre-inspection / Post-inspection	3-3
Cockpit	3-5
Radio.....	3-7
Communication.....	3-7
Intercom.....	3-7
Transponder	3-7
Optional Equipment	3-7
Emergency Locator Transmitter	3-7
Propeller.....	3-7
Engine.....	3-8
Firewall Forward	3-8
Fuselage	3-10
Landing Gear	3-11
Wing / Center Section.....	3-12
Rear Spar Doubler.....	3-13
Empennage.....	3-14
Vertical Stabilizer	3-14
Rudder	3-14
Stabilator.....	3-16
Anti-Servo Tab & Pitch-trim Servo.....	3-16
Angle-Of-Attack.....	3-17
Paperwork.....	3-17

OVERVIEW

The condition inspection is performed annually or every 100 hours of operation, depending on the terms of use for the aircraft. The condition inspection is essential for insuring safe operation throughout the aircraft's service life. In order for anyone to perform a condition inspection on an S-LSA category RV-12 aircraft they must possess at least one of the following SPECIFIC CERTIFICATION REQUIREMENTS:

- ◆ A person certified as "Repairman (light-sport aircraft)-Maintenance" rating
- ◆ FAA certificated A&P technician

◆ NOTE: FOR THE INSPECTION CHECKLIST SEE SUPPLEMENT PAGE 18-5.

◆ NOTE: This maintenance manual is intended to be used in conjunction with the RV-12 Kit Assembly Instructions (KAI) when completing maintenance or repair processes.

The inspector will identify any wear, corrosion or damage that would compromise the safe operation of the aircraft. All inspection practices must comply with the current Advisory Circular 43.13-1B regardless of the content of this manual.

During the inspection, locations concealed from direct line of sight may be accessible by touch or with use of a mirror. Inaccessible places do not require

inspection provided the airframe has been constructed and used within the terms defined by the manufacturer.

The *Inspection Checklist* provided in the Supplement will be a guide for the inspection procedure. The bold print identifies each category of inspection and the general symptoms to check for throughout that category. Each category inspection item identifies specific things to check for with that item. Generally the items on the *Inspection Checklist* will correspond to the bulleted items in this chapter. It is always important to be generally observant to the condition of the aircraft regardless of what is specified for inspection.

During the inspection make note in the space provided or on a separate document of any discrepancies with parts, components or fasteners that require service or replacement. Complete the entire inspection prior to performing service or repairs. This chapter recommends tools that are useful for each inspection category.

INSPECTION DESCRIPTION

TOOLS	
Inspection Mirror <ul style="list-style-type: none"> ◆ Clean rags ◆ Straight edge (avoid scratches; tape along one edge) ◆ Small square ◆ Screwdrivers: <ul style="list-style-type: none"> ▪ #2 Phillips ◆ Socket: <ul style="list-style-type: none"> ▪ 3/8 	<ul style="list-style-type: none"> ◆ Multi-meter ◆ Compression tester ◆ Torque wrench (in/lbs & ft/lbs) ◆ Tire pressure gauge ◆ Jack ◆ Padded stands ◆ Step ladder ◆ Flashlight ◆ Magnifying Glass ◆ Wing Retention Pin Bushing Gauge

PRE-INSPECTION / POST-INSPECTION

Perform the preliminary systems check and engine run-up. The Rotax line maintenance manual provides the run-up procedure for the engine. Test all of the engine systems and controls. Test all of the airframe systems and controls. Make note of any abnormalities or dysfunctional components. Record the applicable values in the spaces given on the *Inspection Checklist*. After the systems check, proceed with the following:

■ **CAUTION: ALWAYS SUPPORT THE FLAPERON DURING WING REMOVAL AND STORAGE.**

1. Remove the left and right wing.
2. Remove all access covers, inspection plates, fairing and cowling shown in **Figure 4**.

Tools	3/8 socket #2 Phillips screwdriver
Service rating	Line
Minimum Certification	LSA-RM, or A&P

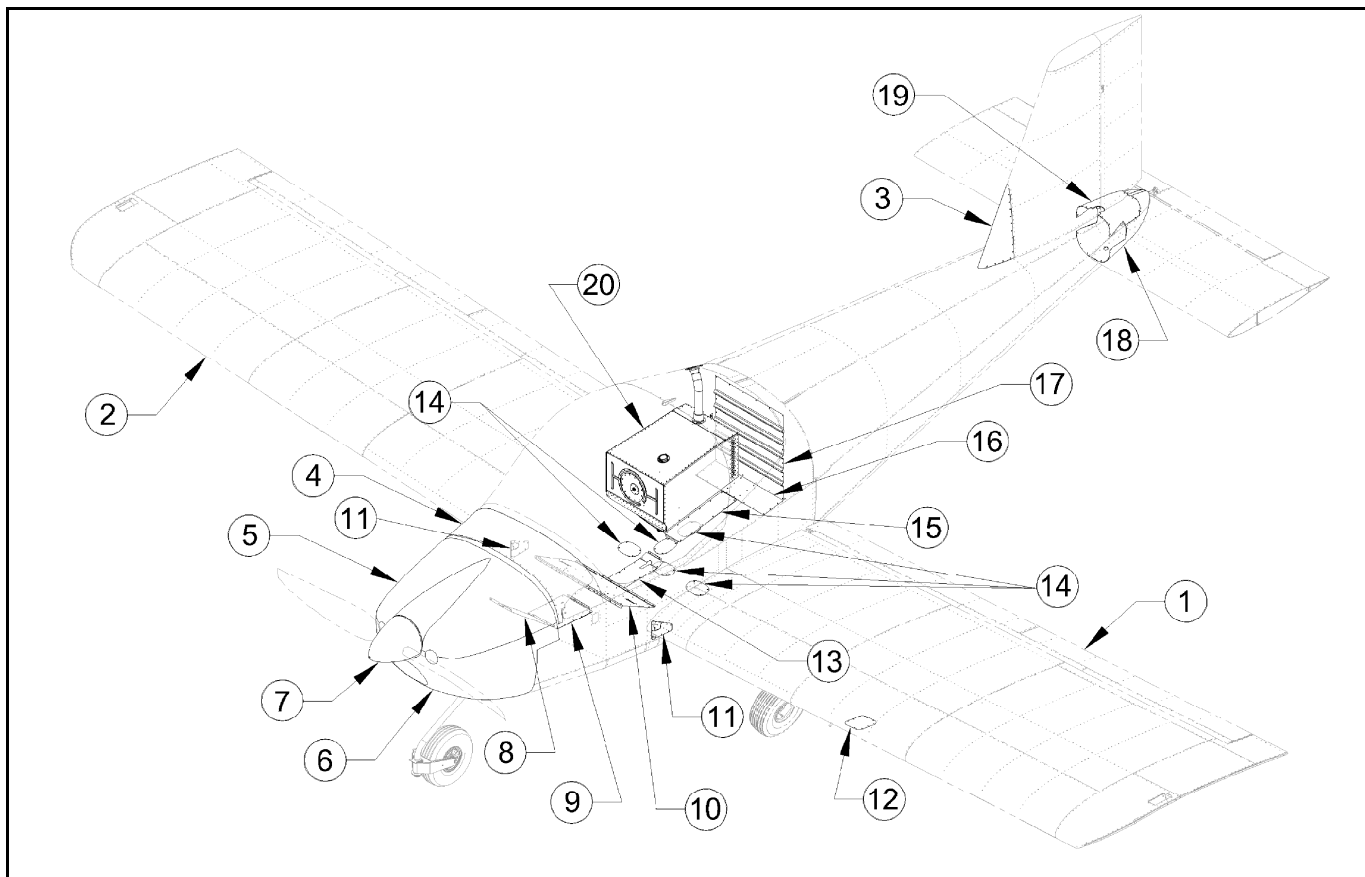


Figure 4: Remove for inspection

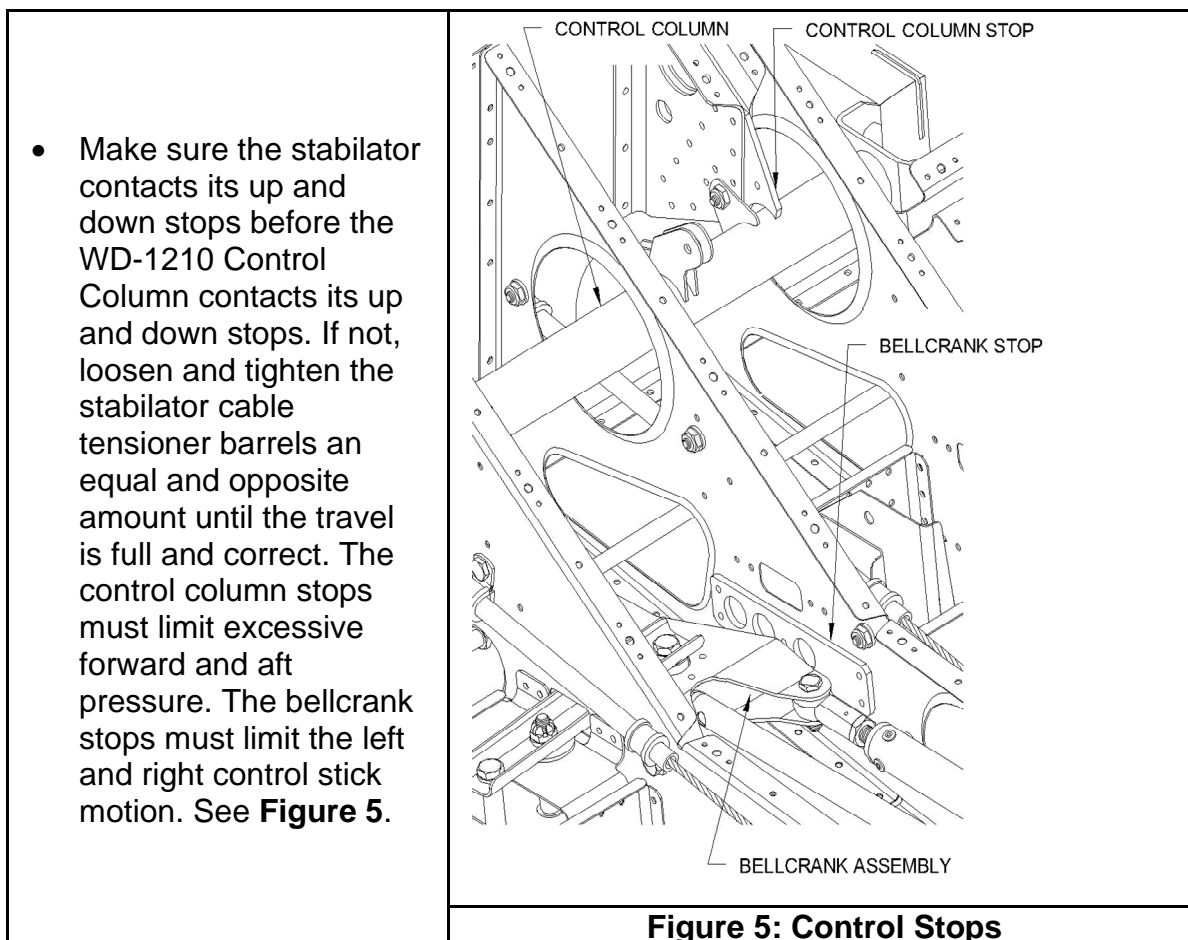
*Ref. #	Name	*Ref. #	Name
1	Left Wing	12	Access Hatch
2	Right Wing	13	Seat Floor Cover
3	Forward Skin	14	Cover Plates (5)
4	Upper Forward Fuselage Skin	15	Baggage Floor Cover
5	Top Cowl	16	Baggage Cover
6	Bottom Cowl	17	Baggage Bulkhead Corrugation
7	Spinner	18	Lower Tailcone Fairing
8	Tunnel Cover	19	Upper Tailcone Fairing
9	Step Floor Cover	20	Fuel Tank Assembly (see chapter 13 for draining the fuel tank)
10	Seat Ramp Cover		
11	Fuselage Side Cover (2)	* - Not numbered in order of removal	

3. Perform visual inspection for and make note of any oil, exhaust, fuel, hydraulic or reother leaks.
4. Thoroughly clean engine, fuselage, cockpit, undercarriage and other areas as needed to allow thorough inspection.
5. Throughout the inspection check for cracks, signs of fatigue, corrosion, wear, deformation, and/or failure. **Always check condition and security of all safetied fasteners.**

COCKPIT

Tools	
<ul style="list-style-type: none"> ◆ Magnifying glass ◆ Flashlight ◆ Inspection mirror 	<ul style="list-style-type: none"> ◆ Clean rag ◆ Straight edge

- Inspect the aft face of the firewall for corrosion, deformation or cracks, especially around fasteners.
- Inspect each occupant harness latching mechanism, the condition of the strap material and stitching.
- Check the installation, fasteners and condition of each seat back.
- Inspect the canopy windscreen and aft window for deterioration or breakage. The canopy latch and latch block must be in good condition and installed correctly. Test the security of the roll bar and check for any sign of fatigue. Check the canopy frame for cracks / security.
- Check that the control panel items are marked permanently, clearly, and correctly.
- Inspect all switch panel and instrument panel connections for security and condition.
- Test all position lights, landing lights and cockpit lights for operation.
- Check the condition of in-service fuses and the condition and presence of spare fuses.
- Run a rag along the control cables to check for frays or broken strands that will snag the cloth. The stabilator cables must be aligned with the corresponding pulley and free from physical interference. The locking clips on the tensioner barrels must be installed and secure.
- Actuate the control stick forward and aft to check the pulley operation. The pulleys must turn smoothly, without lateral play. With the control stick pulled back the trailing edge of the stabilator must be up.
- Hold either control stick stationary and gently wiggle each push/pull rod; there must not be free play or loose parts. Check the rod-end jam nuts for proper torque and check the security of the rod-end connection fasteners.
- Actuate the control stick left and right. Operation must be smooth from stop to stop.
- Operate the flap lever to each detent. At each flap lever detent, check the full motion of the control stick for smooth operation.



- Actuate the vent door on each side of the cockpit and confirm a clear passage. Actuate the cabin heat push/pull cable, confirm a clear passage to the cabin (when 'On'), and smooth operation. Confirm that the heat door has a tight seal to the firewall when heat control is in the off position.
- Test the full motion of each of the engine control cables for smooth operation and proper operation of the friction (throttle control) or position lock (choke control).
- Test the operation of the fuel valve. Check the security of the electric fuel pump and the fuel flow transducer.
- Inspect the system lines that run along the center, of the bottom skin. Check all fittings for leaks. The system lines include (from left to right while seated in the cockpit); electrical wire bundle & static line, fuel return, left brake line, right brake line, and fuel supply. There must be snap bushings at each bulkhead and clamps or brackets to hold the lines secure.
- Test the operation of the brake pedals. Constant pressure must not cause any of the brake pedals to bottom out. Without pressure, each brake pedal must automatically return to the original position.
- The rudder pedals must move opposite and relative to each other with no slack between them. The rudder stops on the lower rudder hinge must limit the rudder and pedal travel.

RADIO

- Check the connections, external condition, and installation of each component; the main unit, the antenna and the jacks.

COMMUNICATION

- Test the operation of the unit per manufacturer specs. (Refer to the Garmin or Dynon installation manual)

INTERCOM

- (If Installed) Test the operation of the unit per manufacturer specs. (Refer to the FlightCom manual)

TRANSPONDER

- Make sure the transponder is in compliance with FAR 91.403 and log entries current.

OPTIONAL EQUIPMENT

- Confirm that optional equipment installed on the aircraft is correct and authorized. Optional equipment is offered and installed on the aircraft by the manufacturer at the time of purchase. Refer to the related manual for special procedures for inspection. (See applicable manual provided with the component)

EMERGENCY LOCATOR TRANSMITTER

- The ELT must be inspected in compliance with the FAR Part 91.207 (d) and accompanied by a logbook entry.

PROPELLER

(Refer to Sensenich Propeller manual)

▲ WARNING: THE MASTER POWER AND BOTH IGNITION SWITCHES MUST BE SHUT OFF DURING INSPECTION OF THE PROPELLER. SERIOUS INJURY OR DEATH WILL RESULT IF ENGINE IS UNINTENTIONALLY STARTED BY TURNING THE PROPELLER.

- Check the spinner cone and back-plate fasteners for wear and security.
- Inspect hub and fasteners for cracks and wear.
- Check the pitot tube and bushing for wear and condition.
- Check hub fastener torque.
- Inspect the leading edge of the blades for loose metal. Inspect each entire blade for

cracks, missing material, and delamination.

● **NOTE: PERFORM THE PROP TRACK TEST WITH THE SPARK PLUGS REMOVED.**

- Test prop track by placing a stationary object in contact with the forward or aft face of one of the blade tips. Then rotate the propeller to bring the opposite blade to the same point. An off-track propeller will not come to the same point.

ENGINE

(Refer to Rotax manual)

▲ **WARNING: THE MASTER POWER AND BOTH IGNITION SWITCHES MUST BE SHUT OFF DURING INSPECTION OF THE ENGINE, UNLESS INSTRUCTED OTHERWISE. SERIOUS INJURY OR DEATH WILL RESULT IF ENGINE IS UNINTENTIONALLY STARTED.**

▲ **WARNING: ALLOW THE ENGINE AND APPLICABLE COMPONENTS TO COOL BEFORE PERFORMING SERVICE OR INSPECTION. HOT ENGINE COMPONENTS WILL CAUSE SERIOUS BURNS.**

- Refer to the Rotax line maintenance manual for proper inspection procedure for engine and components supplied with engine. The Rotax manual will also provide fluid check and change procedure.

FIREWALL FORWARD

▲ **WARNING: THE MASTER POWER AND BOTH IGNITION SWITCHES MUST BE SHUT OFF DURING INSPECTION OF THE FIREWALL FORWARD COMPONENTS. SERIOUS INJURY OR DEATH WILL RESULT IF ENGINE IS UNINTENTIONALLY STARTED.**

▲ **WARNING: ALLOW THE ENGINE AND APPLICABLE COMPONENTS TO COOL BEFORE PERFORMING SERVICE OR INSPECTION. HOT ENGINE COMPONENTS WILL CAUSE SERIOUS BURNS.**

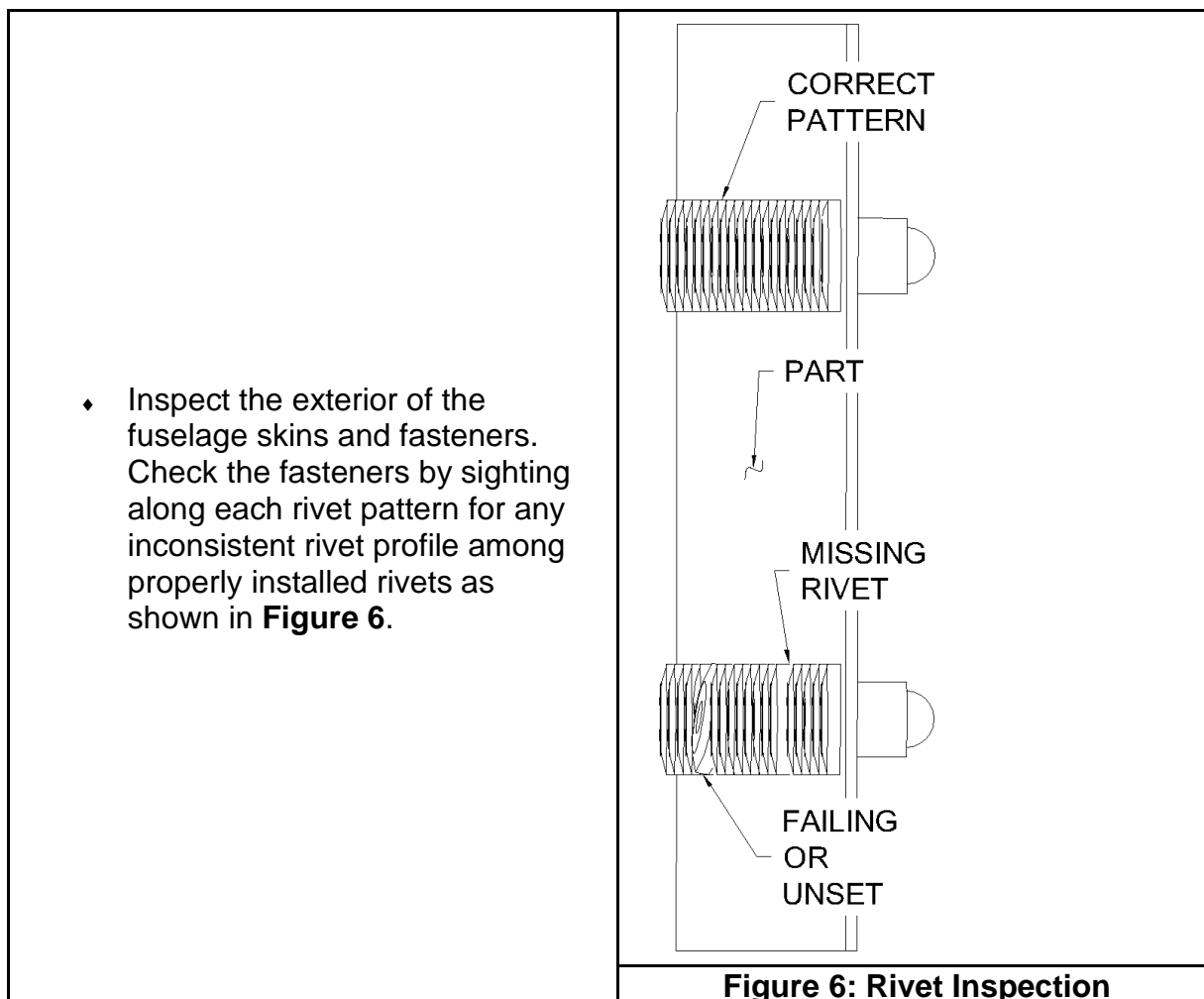
Tools	
<ul style="list-style-type: none"> ◆ Magnifying glass ◆ Flashlight ◆ Inspection mirror 	<ul style="list-style-type: none"> ◆ Clean rag ◆ Compression tester ◆ Multi-meter

- Note any signs of leakage, corrosion, and high temperature. Check for wear to hoses, cables, wiring harnesses, etc. as a result of vibration while in contact with another object.

- Check the forward side of the firewall especially around components and fasteners, around the battery, oil tank assembly, heat exchangers, cowl attach locations, engine mount, and nose gear. The firewall must not have any open passages into the cockpit.
- Inspect the engine mount for damaged coating, corrosion and signs of fatigue or cracks. Damaged engine mount coating demands closer examination and repair.
- Inspect the engine vibration isolators for cracks, deterioration and installation.
- Check the engine compartment wiring, including ground wires of the wiring harness. Wire insulation must be secure, intact and flexible; free from cracks, burns, or separation. All wire terminations must be tight.
- Check the battery for proper voltage, condition of the case, and that the connections are secure.
- Engine cooling shroud must be secure and free of cracks.
- Cabin heat cable and connection must be secure and operate smoothly. All ducting must be secure and in good condition. Heat door must close tightly against firewall (when 'Off').
- Check each engine control cable for security and condition along the route to the firewall. The throttle and choke cables must be securely connected to each of the carburetors and in good condition. Throttle and choke cables must operate the carb levers from stop-to-stop.
- Inspect the air filters for cleanliness, attachment and condition.
- Inspect the heat exchangers for proper attachment, cleanliness and condition.
- The flexible lines provided with the engine have a service life defined in the Rotax maintenance manual. Static and other flexible lines must be in good condition, connected and fastened securely.
- Check the fuel lines for good condition, secure mounting, routing and connections. Inspect the the screen and bowl of the gascolator for contaminant build-up. Check the O-ring for condition and deterioration.
- Check the exhaust system for security. Check for signs of exhaust leaks.
- Check exhaust system ball joints for proper anti-seize lubrication.
- Inspect the cowling for overall condition; loose paint, material separation, signs of wear. Check the cowl fasteners and hinges for missing eyelets, security. Check cowl shielding for signs of high temperature and proper attachment to cowl.
- Check for cotter pins in place in the engine mount attach castle nuts.

FUSELAGE

Tools	
<ul style="list-style-type: none"> ◆ Magnifying glass ◆ Flashlight ◆ Inspection mirror 	<ul style="list-style-type: none"> ◆ Clean rag ◆ Straight edge



- Critical areas are where the firewall attaches to the fuselage, each wing spar mates with the fuselage, the tailcone attaches to the forward fuse, and the empennage components attach to the tailcone.
- Visually inspect that both static ports are clear.
- Test the condition and security of the left and right boarding steps.
- Inspect the condition of the electrical connections that correspond to the wing. The connections must be free of corrosion and any damage.
- Inspect the inside diameter of each flaperon torque tube for rust/corrosion and verify that the UHMW plastic spacers are in place in the actuating arms of the flaperon torque tubes.

LANDING GEAR

▲ WARNING: A LIFTED AIRCRAFT MUST BE SECURELY SUPPORTED BY STATIC STANDS OTHER THAN THE JACKING DEVICE. THE AIRCRAFT MAY NOT MOVE FROM ATTEMPT TO SHAKE HORIZONTALLY OR VERTICALLY.

■ CAUTION: ALWAYS USE PADDED STANDS AND ALWAYS DISTRIBUTE THE LOAD ALONG A RIVET PATTERN WITH SEVERAL INTERSECTING RIVET PATTERNS.

● NOTE: REFER TO GENERAL – GENERAL PROCEDURES INDEX FOR INSTRUCTIONS ON LIFTING AND SUPPORTING THE AIRCRAFT.

Tools	
<ul style="list-style-type: none"> ◆ Magnifying glass ◆ Flashlight ◆ Inspection mirror ◆ Torque wrench 	<ul style="list-style-type: none"> ◆ Clean rag ◆ Straight edge ◆ Sawhorses ◆ Tensile weight scale

- ◆ Check all landing gear components; attach locations, and fasteners for cracks and any other signs of fatigue. Throughout the inspection of the landing gear, be observant for signs of hydraulic fluid leakage.
- Inspect each landing gear-leg and attach point Check for evidence of black dust at the attach points which is an indicator of movement.
- Test the security of each of the landing gear-legs. The landing gear components may not have any free play in any direction.
- Check that all attach hardware is at proper torque. Remember to account for the prevailing torque of the nut. If a torque wrench is used on the head of the bolt also account for the torque to overcome the friction to turn the bolt shank within the assembly.
- Check the main U-1220 gear legs for corrosion or bubbled paint that may lead to corrosion.
- Test the security of the brake lines and inspect for signs of wear.
- Grab and shake the wheels and tires to check for bearing looseness.
- Check for smooth, low resistance rotation of each wheel.
- Check for excessive play in both brake calipers.
- Check the brake shoe linings, brake disc and wheel assembly per Matco manufacturer specifications.
- Rotate the nose fork about the gear-leg. Check for lubrication. Check the break-out force per KAI.

- Use a straight edge to check that the unloaded gear-leg is straight, between the factory bends.
- Inspect the condition of fasteners and cotter pins, and the condition of attach locations at the nose fork pivot point and the three wheel axles.
- Inspect the tires for cracks, wear, and tire pressure. Valve and valve stem in good condition, and capped.
- Check the nose gear-leg coating, welds, and brackets for cracks and signs of fatigue.
- Check nose fork pivot point for lubrication.
- Check the nose fork, nut and cotter pin for condition and signs of fatigue.

WING / CENTER SECTION

Tools	
<ul style="list-style-type: none"> ◆ Magnifying glass ◆ Flashlight ◆ Inspection mirror ◆ Wing retention pin bushing gauge 	<ul style="list-style-type: none"> ◆ Clean rag ◆ Straight edge ◆ Multi-meter

- Inspect the wing skins and fasteners for signs of damage or deformation. Check the fasteners by sighting down each rivet pattern for any inconsistent rivet profile among properly installed rivets. Any damage observed on the wing skins demands thorough inspection of the understructure of the damaged wing.
- Use a flashlight and an inspection mirror to inspect spars, ribs and attach angles on the interior of each wing. Especially the inboard-most ribs and ribs at the flaperon hinge attach points. The aft outboard portion of the wings can be viewed through the lightening holes in the outboard portion of the rear spar.
- Inspect the main spar, rear spar and stub spar for corrosion, deformation, signs of wear or fatigue. Inspect the rear spar and stub spar for lubrication at the inboard end.
- Inspect the flaperon condition and operation. Inspect the flaperon skins and fasteners for damage or deformation. The flaperon must swing smoothly without free play in any direction. Inspect the flaperon control connection for signs of wear. Check the fasteners in the flaperon hinge brackets on each wing for security. Inspect inner surface of flaperon torque tubes for rust and corrosion.
- Inspect the condition of the electrical connections that correspond to the fuselage. The connections must be free of corrosion and damage.
- Test the stall warning Vane for freedom of movement. Check the micro-switch for corrosion, condition and security. Check the wing skin for cracks around the stall warning vane penetration.
- Test the AOA system plumbing for leaks. See the AOA System Test section below.

- Check fuselage pin latching mechanisms for security and proper operation. Test warning circuit by moving each latch independently and verifying warning light.

- Inspect each fuselage pin and all wing retention pin bushings for wear or cracks. Inspect the center section area around the bushings for deformation or cracks. Use the Main Spar Bushing Gauge Pin to check the wear of both ends of all of the wing retention pin bushings. Insert the Gauge Pin into the bushing, then rotate the Gauge Pin. The Gauge Pin is a 'go, no-go' device. If the 'no-go surface' contacts the bushing (or mounting surface), the wing retention pin bushing must be replaced. See **Figure 7**.

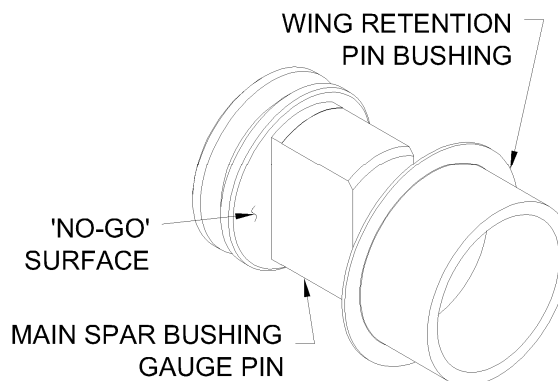


Figure 7: Wing Retention Pin Bushing

- Inspect the center section channel, bulkheads, fasteners and stiffeners for signs of amage or fatigue. Check the center section left and right UHMW retainer block and roller for security and wear.
- Check the fuselage pin latching mechanisms for security and proper operation. Test the warning circuit by unlatching each pin individually to verify it causes the switch panel warning light to illuminate.

REAR SPAR DOUBLER

- If the W-1207B rear spar doubler has been trimmed too much, the finished airplane may exhibit some play at the rear spar junction. This is usually discovered by hearing a “click” and detecting in/out movement when the wing is installed. Increasing the length of the spar doubler is not possible, so it must be removed and replaced with a different, slightly longer, part.
- To determine which part is required, measure the in/out movement of the wing. This will require two people.
- Begin by chocking the tires firmly, so the fully assembled airplane rocks and moves as little as possible.
- Attach a dial caliper to the inboard wing skin as shown below and adjust it so it just touches the side of the fuselage. (Use a spacer between the caliper and the wing skin, if necessary, to clear the rubber wing root seal). One person can rock the wingtip forward and aft while the other checks the indicator, and measures the total play.

- If your aircraft has ES-00076 & ES-00077 Electrical Connectors (See KAI 31B-08 and 31B-18) and the measurement is less than 0.050 no repair is required.
- If your aircraft has tab style VA-262 electrical connectors in UHMW (See KAI 31-02) and the measurement is less than 0.010 no repair is required.
- For repair instructions see Section 5.



Figure 7.1: Inspect Rear Spar Doubler

EMPENNAGE

Tools	
♦ Magnifying glass	♦ Straight edge
♦ Flashlight	♦ Inspection mirror

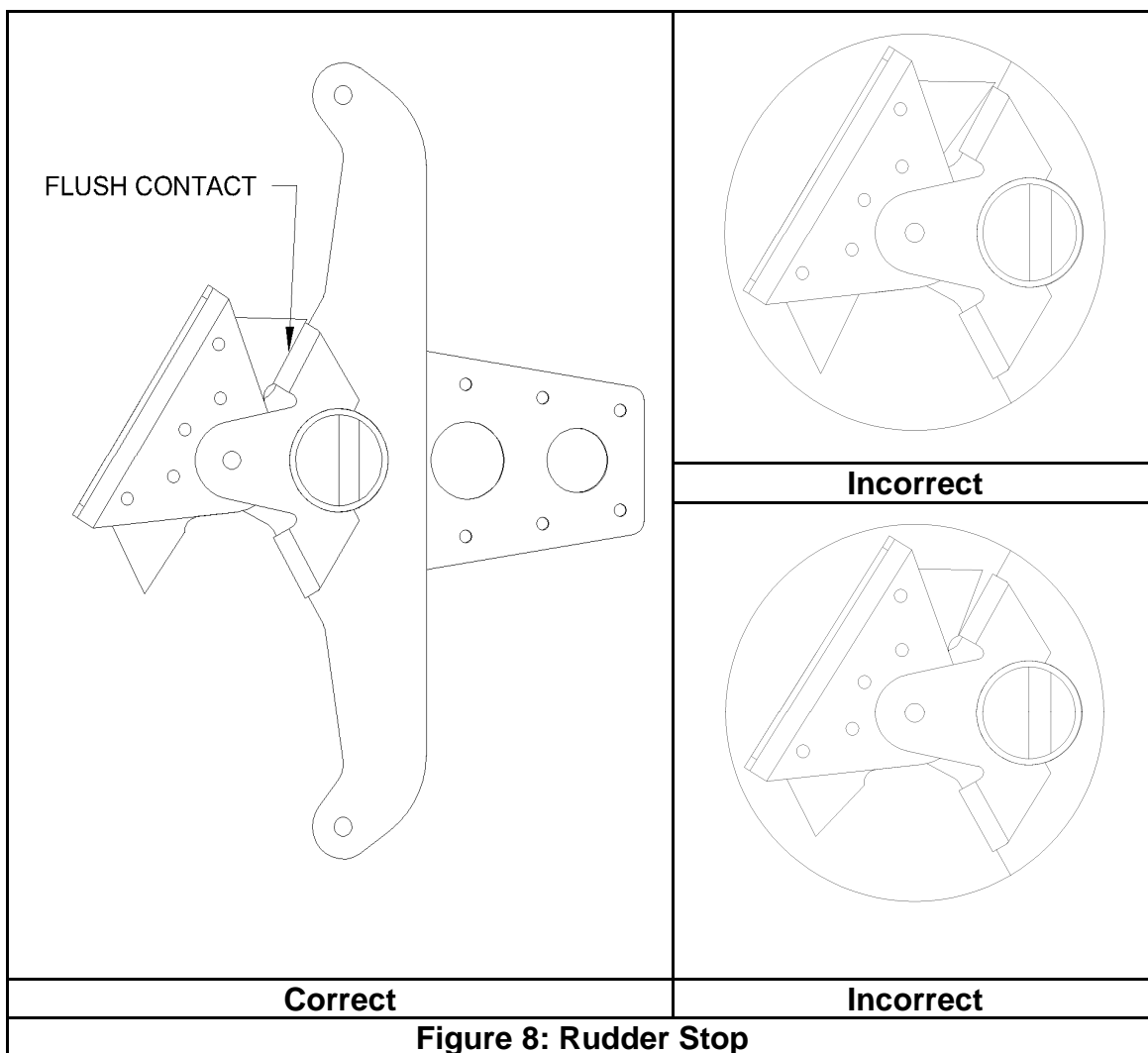
VERTICAL STABILIZER

- Check the main skin and forward skin for deformation or cracks.
- Check the main skin fasteners by sighting along each rivet pattern for any inconsistent rivet profile among similar properly installed rivets.
- Check the forward spar and fasteners for cracks, deformation and signs of fatigue.
- Inspect the rear spar, spar fasteners, and hinges for cracks, deformation and signs of fatigue, especially the areas surrounding the rudder hinge brackets.
- Check the fiberglass fairing for condition and security.
- Check for interference or signs of wear from the rudder.
- Look through the forward spar lightening holes to inspect the rear spar, ribs, and rib flanges for cracks.

RUDDER

- Check the main skin for damage or deformation.
- Sight along each rivet pattern for any inconsistent rivet profile among similar properly installed rivets.
- Check the spar and hinge brackets for cracks, deformation and signs of fatigue, especially the areas surrounding the hinge brackets.

- Check the fiberglass fairing for condition and security.
- Check the rudder control horn for coating damage. Inspect for cracks, missing fasteners and deformation.
- Check the spar bottom rib surrounding the rudder horn for cracks or deformation.
- Inspect the control cable swages, link fasteners and attach area on the control horn for signs of wear or fatigue.
- Check the rudder stops on the lower hinge for wear or deformation.
- Make sure the rudder swings smoothly and the control horn contacts the rudder stops square and flush as shown in **Figure 8**.



STABILATOR

- Check the main skin for damage or deformation.
- Check the main skin fasteners by sighting along each rivet pattern for any inconsistent rivet profile among similar properly installed rivets.
- Inspect the Anti-Servo Tab hinges, fasteners, and safety wire for wear and security.
- Inspect the spar box for cracks, deformation or signs of fatigue, especially the areas surrounding the control horns, hinge brackets, and counterbalance brackets.
- Use an Inspection mirror to inspect the ribs for cracks or deformation.
- Inspect the coating on the control horns, counterbalance brackets.
- Check the counterbalance arm for straightness and for interior/exterior corrosion, remove bolts if necessary.
- Make sure the counterbalance weights are secure and the fasteners are in good condition.
- Inspect the hinge brackets, stops, and fasteners for signs of wear and security.
- Inspect the control horns and fasteners for wear and security.
- Check the control cable fasteners for security or signs of wear.
- The stabilator must swing smoothly and be limited only by the hinge stops. Make sure that both hinge brackets on the tailcone contact their corresponding hinge stop on the stabilator squarely and simultaneously.

ANTI-SERVO TAB & PITCH-TRIM SERVO

- Check the anti-servo tab skins for damage or deformation.
- Check the anti-servo tab fasteners by sighting along each rivet pattern for any inconsistent rivet profile among similar properly installed rivets.
- Check the spar and attach hinge for deformation and signs of fatigue.
- Inspect the control horns and surrounding area for deformation, cracks, and signs of fatigue.
- Check the control horn fasteners for wear and security.
- Inspect the pitch-trim servo push rod and link for damage or signs of fatigue.
- Inspect the pitch-trim servo, and servo tray for deformation or cracks.
- Check the fasteners and bushings that connect the pitch-trim servo tray to the tailcone for security and wear. There should be very little movement in the tab when the stabilator is held fixed.
- Check the electrical connections and wire for condition and wear.
- Test the operation of the AST by actuating the stabilator through its full range of motion with the trim adjusted to the full nose up and full nose down settings. AST movement must be smooth and relative to the stabilator movement. There must not be any interference with the AST and the pitch-trim servo components at any point of the stabilator travel.

ANGLE-OF-ATTACK SYSTEM TEST

Tools	
<ul style="list-style-type: none"> ◆ Syringes - two req'd (35cc or similar) ◆ Vacuum hose (or soft plastic tubing) 	<ul style="list-style-type: none"> ◆ Modeling clay

NOTE: THE AOA SYSTEM PLUMBING MUST PASS THIS LEAK TEST DURING EVERY INSPECTION AND EVERY TIME THE WINGS ARE REMOVED AND INSTALLED.

WHEN PERFORMING ANY AOA, STATIC, OR PITOT SYSTEM PRESSURE TEST ON A DYNON SKYVIEW SYSTEM IT IS REQUIRED TO BE AT SOFTWARE VERSION 15.0.4 (OR GREATER) AND ALL TESTING MUST BE PERFORMED IN THE SETUP MENU > HARDWARE CALIBRATION > ADAHRS CALIBRATION > PITOT/STATIC TEST MODE.

After the AOA system has been properly calibrated in flight, this test is used to test the AOA system plumbing integrity during every inspection and every time the wings are removed and re-installed.

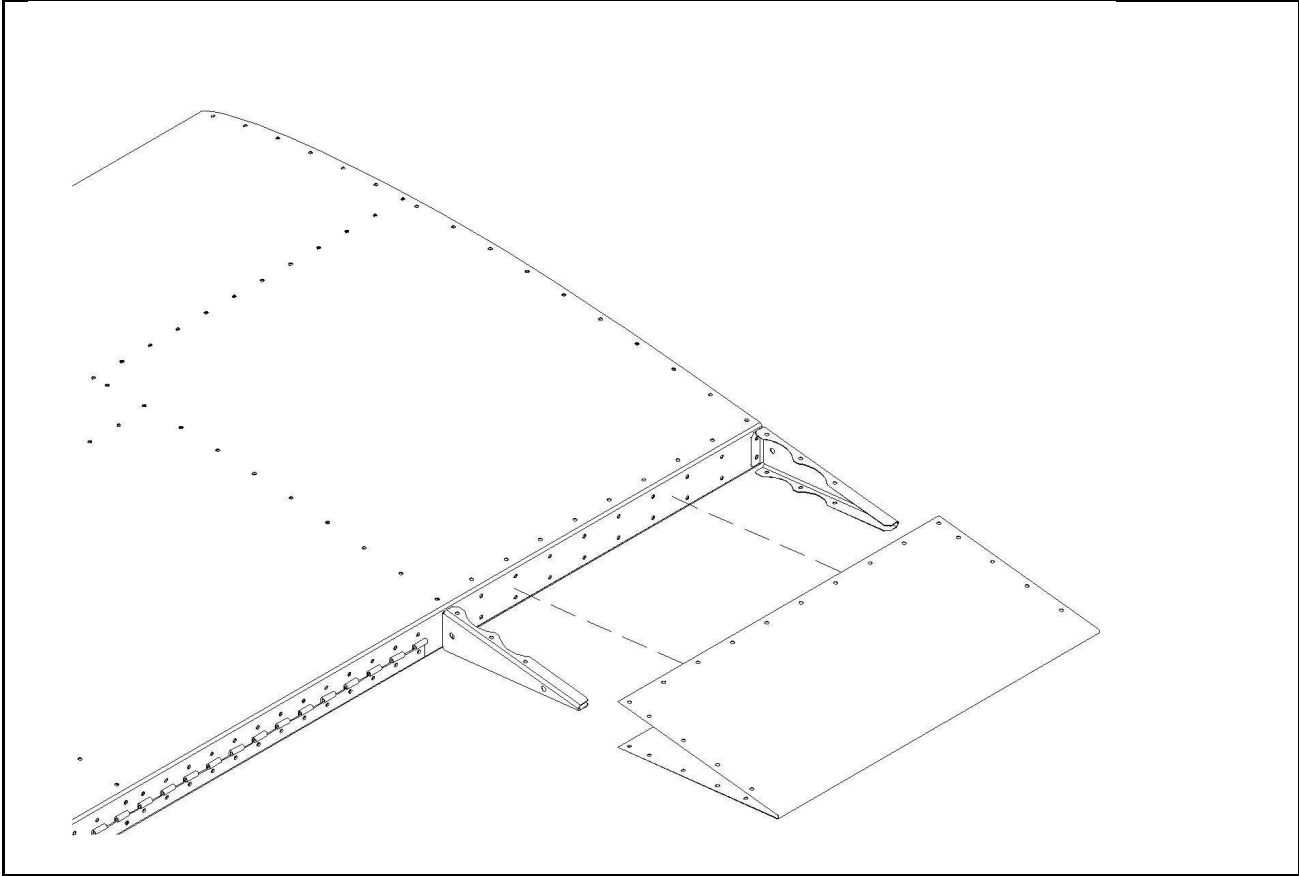
- Using a 35cc syringe push plunger in to 7.5cc, hook-up syringe & vacuum hose to pitot tube, turn-on EFIS, use syringe to slowly, carefully push air into pitot, look for airspeed indication on EFIS, push-in syringe until 130 kt indicates then stop pushing-in.
- Using a second syringe push plunger in to 7.5cc. Use modeling clay to hook-up the syringe and vacuum hose to the AOA port.
- Pressurize the AOA port. Watch the EFIS AOA indicator. Increasing AOA port pressure will cause the EFIS AOA indicator to move from green to red. Do not apply more pressure than necessary to move the AOA indication into the red zone. Once the AOA indication is in the red zone stop pushing in the syringe.
- Move the left wing tip back and forth, as per the REAR SPAR DOUBLER instructions in the WING/CENTER SECTION, while performing the AOA system leak test to verify AOA system integrity.
- The maximum allowable AOA system leak rate is less than full AOA indicator scale, from red to green, in one minute.
- If the AOA system does not hold test pressure for the required time inspect the modeling clay to wing seal before inspecting other AOA system components. Inspect and repair or replace any faulty AOA system components, as necessary. If faulty components were replaced or repaired re-test the AOA system plumbing integrity.

PAPERWORK

- Make the appropriate log book entries.
- Save the completed checklist in the aircraft file.

THIS PAGE INTENTIONALLY LEFT BLANK

CHAPTER 4 - STRUCTURAL REPAIRS



OVERVIEW

Visible deformation of or damage to any aircraft skin warrants a complete inspection of the underlying parts or structures. If all damaged parts are replaced in accordance with the Kit Assembly Instructions KAI no consultation of the manufacturer is necessary.

Small patch repairs to skins as outlined in AC 43.13 are allowed without consulting the aircraft manufacturer if the total patch area does not exceed 60 square inches. Repair to interior structural parts of the airframe or skin repairs (other than replacement of the entire skin or patches to skins) of more than 60 square inches are not allowed without consulting with the airplane manufacturer and receiving approval of the planned method of repair. Note: Integral stringers formed on the edge of skins are considered interior structure.

• NOTE: This maintenance manual is intended to be used in conjunction with the RV-12 Kit Assembly Instructions (KAI) when completing maintenance or repair processes.

• NOTE: For more information regarding riveting, metal working, fiberglass, fluid fittings, priming, painting and more refer to the KAI Chapter 5; Construction Materials, Processes & Useful Information.

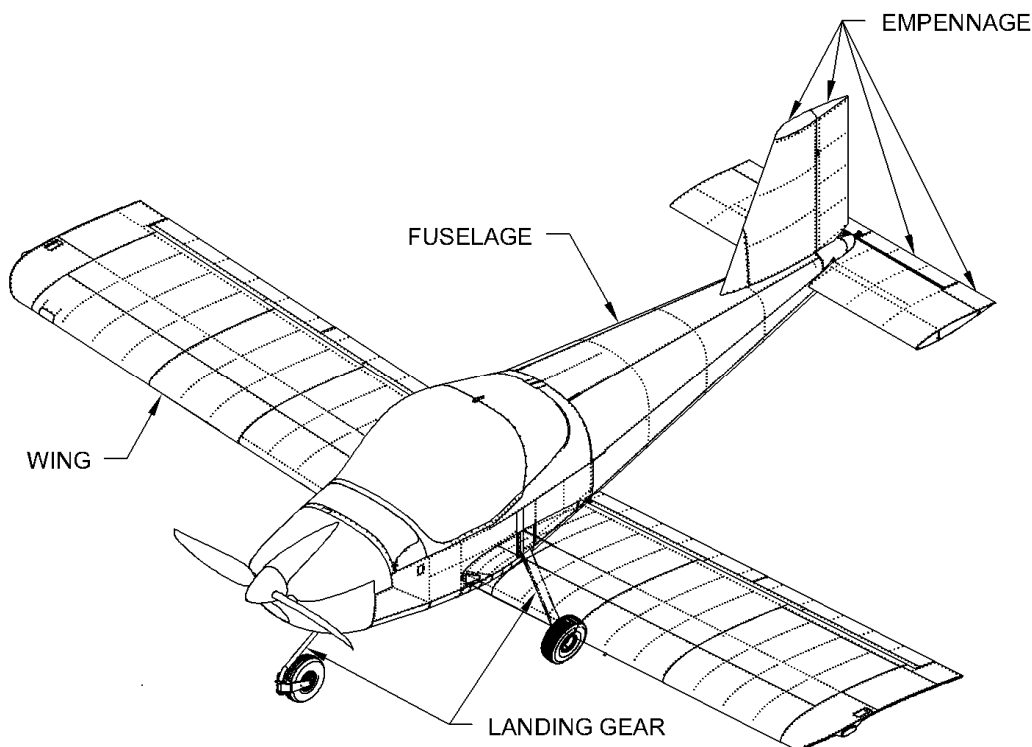
• NOTE: Stop drill cracks per AC 43.13. Report any cracks to Van's Aircraft using the feedback form found at the back of this manual.

• NOTE: See Section 17, Substitute Parts, for rivet substitutions that may simplify maintenance and repair.

MINIMUM CERTIFICATION

The minimum certification for completing a repair to aircraft skins is an LSA Repairman – Maintenance or an FAA certificated A&P technician. Refer to the KAI to identify individual parts and their corresponding part numbers.

CHAPTER 5 - STRUCTURES



OVERVIEW	5-2	Installation	5-14
FUSELAGE.....	5-2	Main wheel and tire assembly removal.....	5-15
Components	5-3	Installation	5-15
WING AND FLAPERON	5-4	Nose wheel and tire assembly removal	5-16
Components	5-5	Installation	5-16
EMPENNAGE.....	5-6	Main inner tube replacement	5-16
Components	5-7	Nose inner tube replacement.....	5-17
LANDING GEAR.....	5-8	Flaperon hinge replacement.....	5-17
Components	5-9	Rudder hinge replacement	5-18
NOSE WHEEL & GEAR LEG FAIRINGS ..	5-10	Stabilator hinge replacement.....	5-19
Components	5-10	Main gear removal	5-21
Wheel Fairings	5-11	Installation	5-21
Optional Components.....	5-11	Nose gear removal	5-21
SERVICE	5-12	Installation	5-22
Supplies	5-12	Belt and Harness replacement	5-22
Tools.....	5-12	Canopy latch block replacement.....	5-23
Expendable.....	5-12	Step replacement	5-23
Replaceable.....	5-12	Rear Spar Doubler Replacement.....	5-23
General	5-13	Service Schedule Procedures	5-25
Wing removal.....	5-13	Wing attach location lubrication	5-25
Installation	5-13	Fuselage pins.....	5-25
Wing retention pin bushing replacement.....	5-13	Stub spar and Rear spar	5-25
In Center Section:.....	5-13	Flaperon control connection lubrication	5-25
In Wing Spars:.....	5-14	Flaperon bearings lubrication	5-26
Canopy and frame removal	5-14	AST attach hinge lubrication.....	5-26
		Nose wheel bearings replacement	5-26
		Main wheel bearings lubrication	5-27
		Nose fork pivot tension and lubrication.....	5-28
		Tire Assem. Balancing Procedure.....	5-29

OVERVIEW

The RV-12 airframe uses blind (pop style) rivets as the primary fastener. The wings are removable without the need of tools. Screws, bolts and solid rivets are used where necessary.

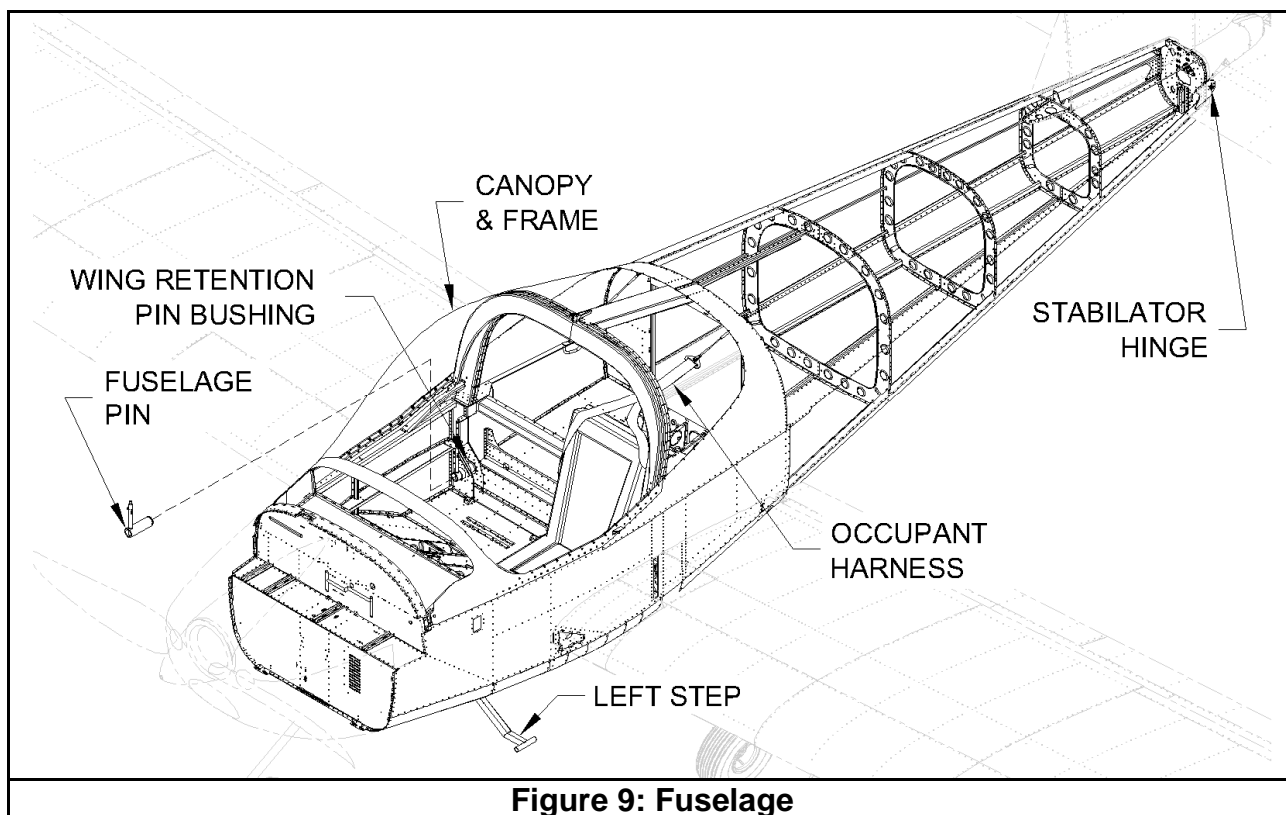
• NOTE: PRIOR TO PERFORMING STRUCTURAL REPAIRS READ CHAPTER 4 FOR LIMITATIONS.

• NOTE: THIS MAINTENANCE MANUAL IS INTENDED TO BE USED IN CONJUNCTION WITH THE RV-12 KIT ASSEMBLY INSTRUCTIONS (KAI) WHEN COMPLETING MAINTENANCE OR REPAIR PROCESSES.

▲ WARNING: BEFORE PERFORMING ANY MAINTENANCE OR REPAIRS TURN THE MASTER SWITCH 'OFF' AND DISCONNECT THE NEGATIVE (-) BATTERY CABLE FROM THE BATTERY.

FUSELAGE

The fuselage will be identified as the forward fuselage and the tailcone. The forward fuselage is the baggage bulkhead and all airframe parts forward to, and including, the firewall. The tailcone refers to all of the parts behind the baggage bulkhead, excluding the empennage fairing and empennage components.



COMPONENTS

Quantity	Part or Assembly Name	Part Number or Reference
1	Canopy and Frame	C-1201 & WD-1219
1	Fuselage	Refer to KAI
2	Fuselage Pin	WD-1217
4	Wing Retention Pin Bushing	W-1206U
1	Latch Block	C-1205
2	Occupant Harness System	See shaded items below & Refer to KAI
1	Shoulder Harness	
1	Lap Belt	
1	Crotch Strap	
1	Left Step	WD-1233-L
1	Right Step	WD-1233-R

WING AND FLAPERON

The wing and flaperon are removable as an assembly from each side of the fuselage. Each wing mates to the fuselage at three points; the stub spar, the main spar and the rear spar. Two fuselage pins secure both main spars to the center section of the fuselage. Electrical and control connections connect automatically during wing attachment. The left wing has a stall warning sender installed. With the wing detached from the fuselage, the flaperon is removable.

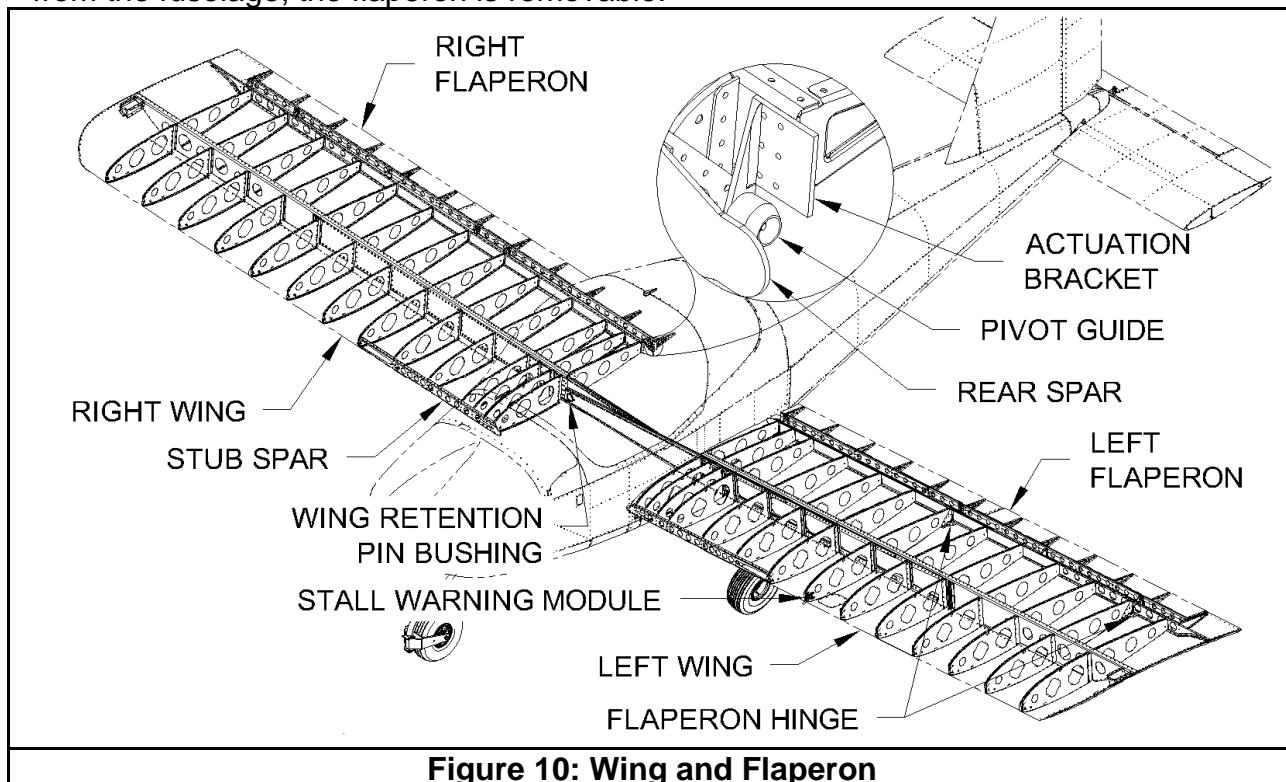


Figure 10: Wing and Flaperon

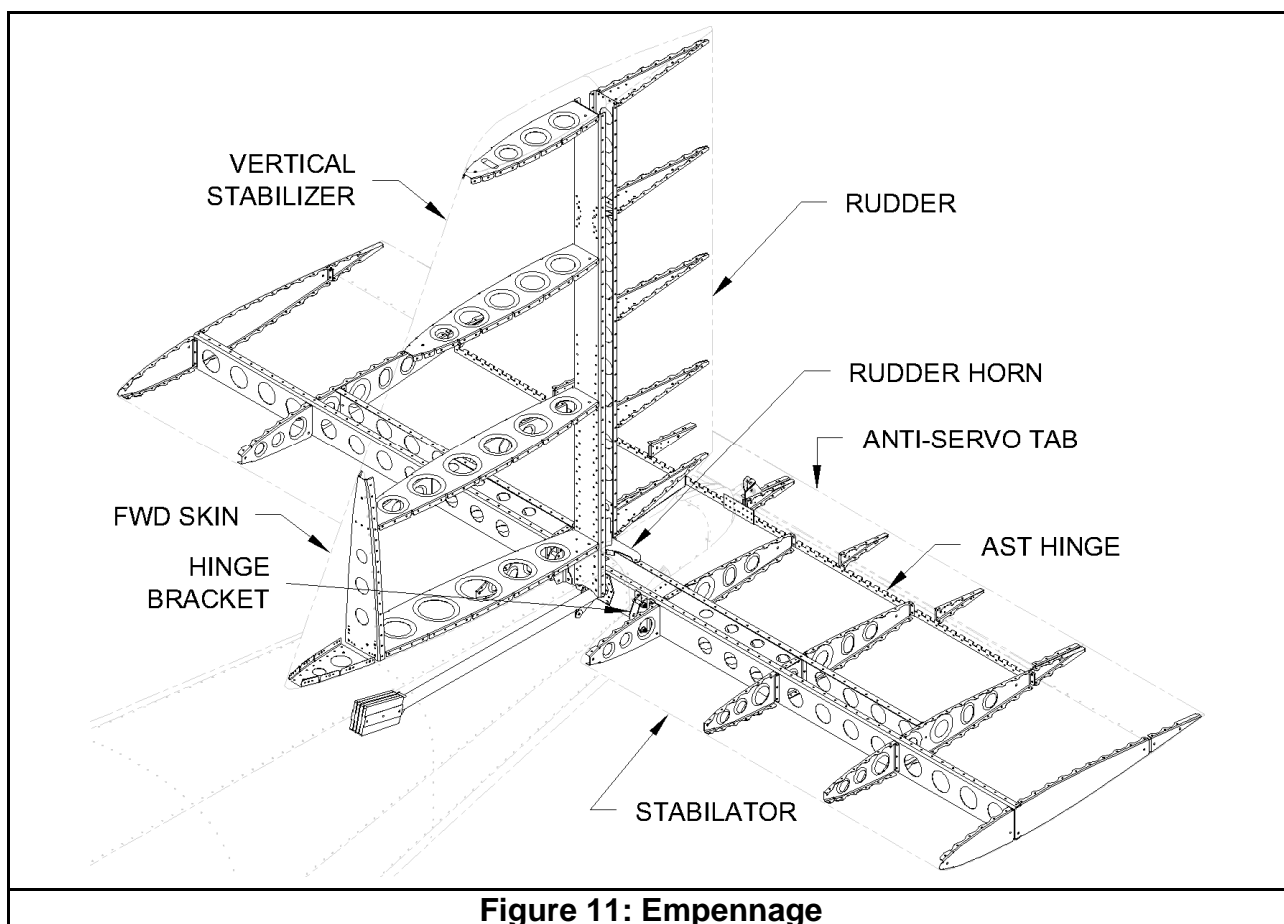
COMPONENTS

Quantity	Part or Assembly Name	Part Number or Reference
1	Left Wing	See shaded items below & Refer to KAI
2	Wing Retention Pin Bushing	W-1206U
1	Stub Spar	W-1208B-L / W-1208C-L
1	Rear Spar	W-1207A-L / W-1207B
1	Stall Warning	See 5-5
1	Right Wing	See shaded items below & Refer to KAI
2	Wing Retention Pin Bushing	W-1206U
1	Stub Spar	W-1208B-R / W-1208C-R
1	Rear Spar	W-1207A-R / W-1207B
1	Right flaperon	Mirror of Left Flaperon (See below)
1	Left Flaperon	See shaded items below & Refer to KAI
2	Flaperon Hinge	MD3614M
1	Actuation Bracket	A-1207-L
1	Pivot Guide	A-1211

EMPENNAGE

The empennage components include the vertical stabilizer, rudder, anti-servo/trim tab, and stabilator assemblies. The vertical stabilizer front and rear spar attach to the tailcone. Fiberglass fairings finish the top of the vertical stabilizer and rudder. The rudder is attached through hinges on the rear spar of the vertical stabilizer. The stabilator attaches to hinges on the aft bulkhead of the tailcone. The AST attaches to the rear of and operates in sequence with the stabilator. The AST also functions as a trim-tab.

Refer to the KAI for empennage component removal and installation.



COMPONENTS

Quantity	Part or Assembly Name	Part Number or Reference
1	Vertical Stabilizer	See shaded items below & Refer to KAI
1	Lower Hinge	VS-1210 / VS-1211A / COM-3-5
1	Upper Hinge	VS-1210 / VS-1211B / COM-3-5
1	Fwd Skin	VS-1204
1	Rudder	See shaded items below & Refer to KAI
1	Rudder Horn	WD-1205
1	Stabilator	See shaded items below & Refer to KAI
2	Hinge Bracket	HS-1213A / HS 1213B / HS-1210
1	Anti-servo / trim tab	See shaded items below & Refer to KAI
2	AST Hinge	HS-1218A / HS-1218B

LANDING GEAR

The landing gear includes the gear-legs, wheels and tires, nose fork and mounting brackets. The nose gear-leg is steel, with welded brackets. The aluminum nose fork attaches and pivots at the lower end. An axle bolt and nut fastens the axle, spacer, and wheel and tire assembly to the nose fork. The main gear-legs are aluminum, fastened to the center section channel with brackets and bolts. Each main axle bolts to the lower end of each gear leg. All three tires are 5.00 x 5 size, either 4-ply or 6-ply tube type aircraft tires are acceptable.

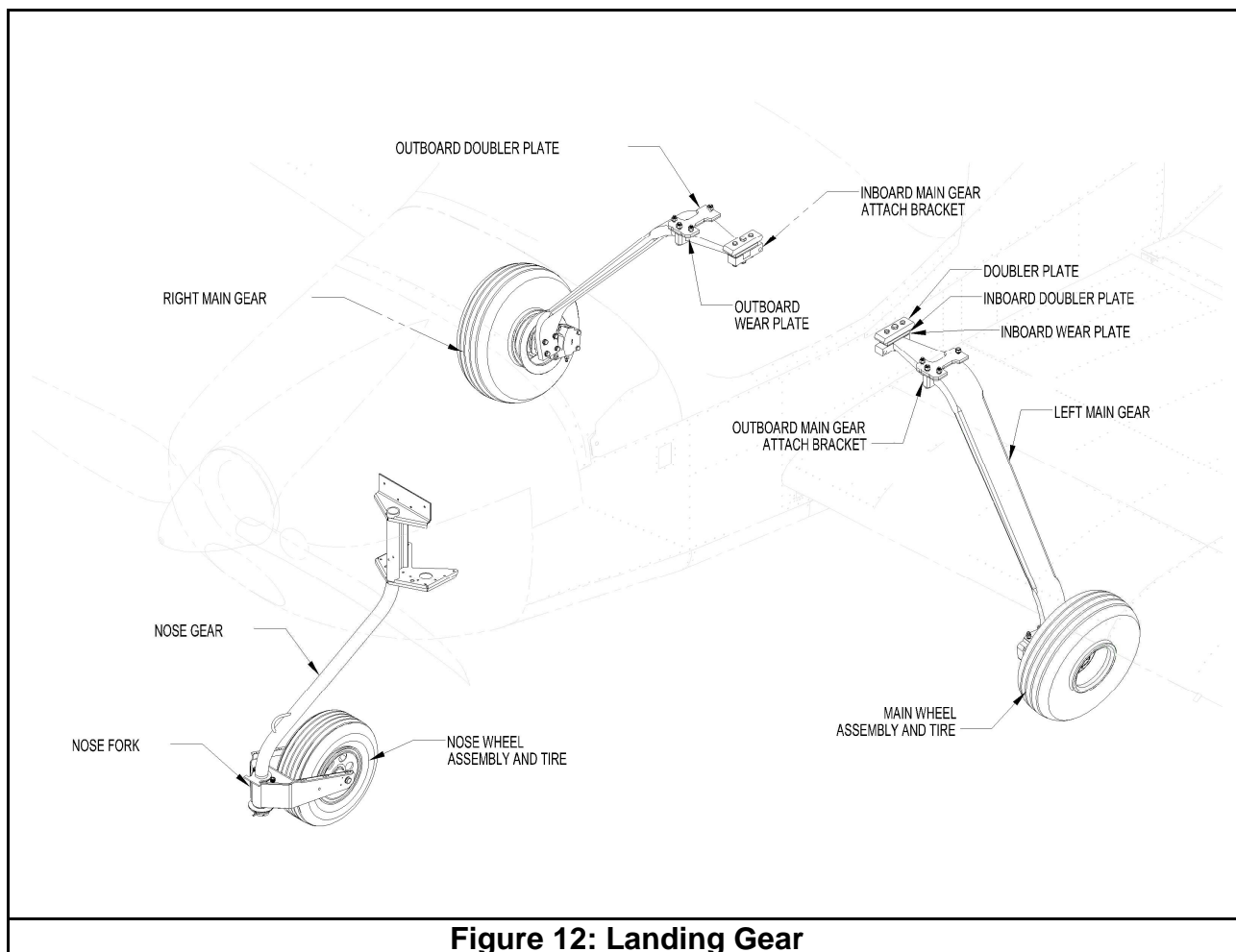


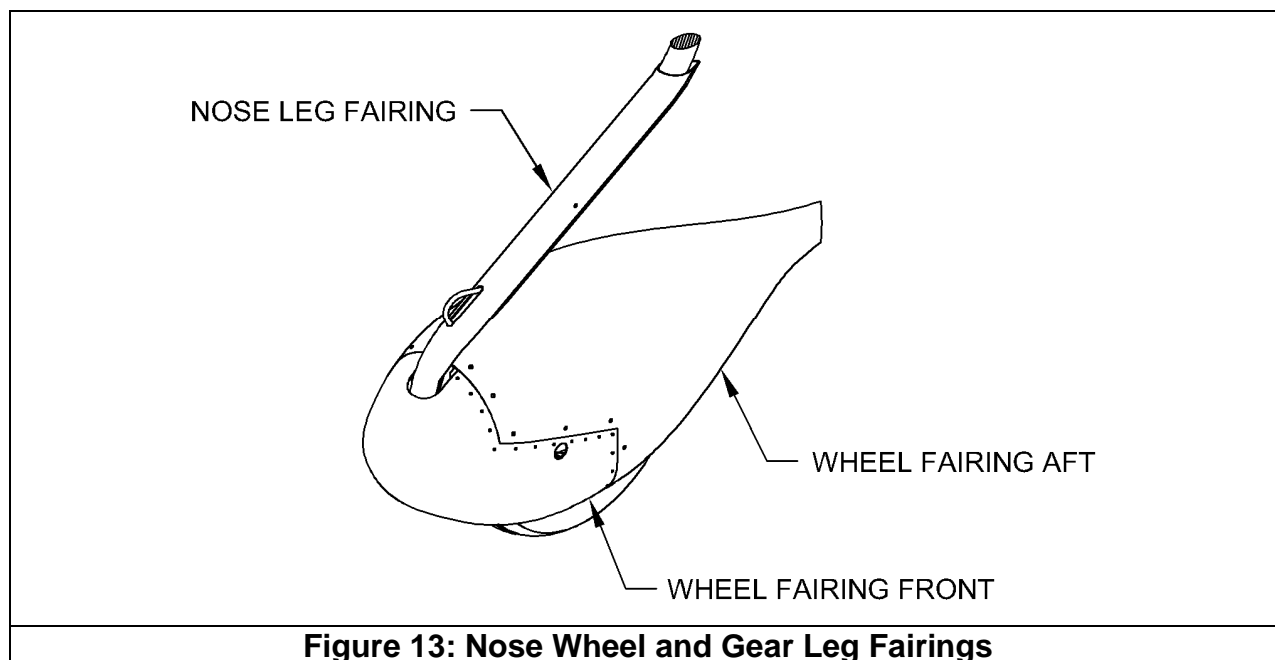
Figure 12: Landing Gear

COMPONENTS

Quantity	Part or Assembly Name	Part Number or Reference
1	Left Main Gear	U-1220-L
1	Right Main Gear	U-1220-R
2	Outbd Main Gear Attach Brkt	U-1202
2	Outbd Doubler Plate	U-1202C
2	Outbd Wear Plate	U-1202D
2	Inbd Main Gear Attach Brkt	U-1203
2	Inbd Wear Plate	U-1203B
2	Doubler Plate	U-1203C
2	Inbd Doubler Plate	
2	Main wheel assembly	See shaded items below
1	Main wheel	U-MHMHE51B
2	Wheel bearings	BEARING LM-67000L-A
1	Axle	MHE51B AXLE
1	Nose gear	WD-1201
1	Nose fork	WD-1230-1
1	Nose wheel assembly	See shaded items below
1	Nose wheel	U-WHLNW51CC.625
1	Axle	U-1210A-1
2	Spacer	U-1210B-1
4	Wave washer	5806-148-3
1	Wheel bearing	N/A
3	Tire	U 5.00 X 5 TIRE
3	Tube	U 5:00X5-6IT

NOSE WHEEL AND GEAR LEG FAIRINGS

The optional nose wheel and gear leg fairings include the glass fabric/epoxy resin nose leg fairing, wheel fairing front and the wheel fairing aft. See **Figure 13**. The nose leg fairing is clamped about the nose leg using a piano hinge held in place by a single screw. The nose leg fairing is slotted to fit about the nose leg winch lug. The wheel fairing aft attaches to the wheel fairing front which in turn attaches to the nose fork. Tow bar access is provided by two 13/16 diameter holes in the wheel fairing front.



OPTIONAL COMPONENTS

Quantity	Part or Assembly Name	Part Number or Reference
1	Wheel Fairing Front	U-00005A
1	Wheel Fairing Aft	U-00005B
1	Nose Leg Fairing	U-00007

WHEEL FAIRINGS

The optional main wheel fairings include the glass fabric/epoxy resin wheel fairing front and the wheel fairing aft. See **Figure 14**. The fairings are attached to the wheel fairing brackets which in turn attach to the bracket mount.

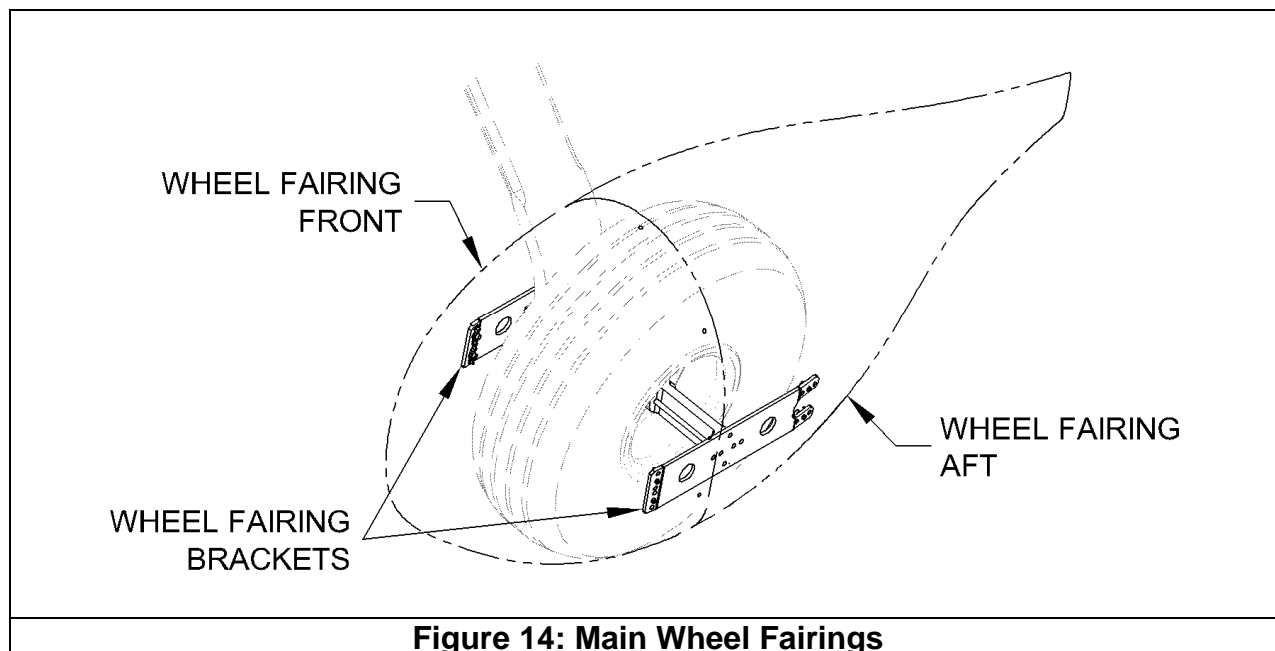


Figure 14: Main Wheel Fairings

OPTIONAL COMPONENTS

Quantity	Part or Assembly Name	Part Number or Reference
2	Wheel Fairing Front	U-00001A
2	Wheel Fairing Aft	U-00001B
4	Wheel Fairing Bracket	U-00002
2	Bracket Mount (inner) not shown	U-00003
2	Bracket Mount (outer)	U-00004

SERVICE

SUPPLIES

TOOLS	EXPENDABLE
<ul style="list-style-type: none"> ◆ Needle nose pliers ◆ Sockets: <ul style="list-style-type: none"> ▪ 3/8 ▪ 5/16 ▪ 7/16 ▪ 1/2 ▪ 9/16 ▪ 3/4 ▪ 1 1/2 ▪ 11 mm ◆ Combination wrenches: <ul style="list-style-type: none"> ▪ 3/8 ▪ 7/16 ▪ 1/2 ▪ 9/16 ◆ Allen wrenches: <ul style="list-style-type: none"> ▪ 3/16 ▪ 1/4 ▪ 5/16 ◆ Screwdriver: <ul style="list-style-type: none"> ▪ #2 Phillips ◆ Mallet ◆ Large wooden dowel <ul style="list-style-type: none"> ▪ 1 1/2 - 1 3/4 inch dia. ◆ Small wooden dowel <ul style="list-style-type: none"> ▪ 1/2 - 1 inch dia. ◆ 2 1/2x3/16 bolt, washer, and nut ◆ Tensile weight scale 	<ul style="list-style-type: none"> ◆ Cotter pins ◆ Safety wire ◆ Wheel bearing grease ◆ Spray lubricant ◆ Inner tube ◆ Hydraulic fluid ◆ Loctite
	<ul style="list-style-type: none"> ◆ See component lists on page: <ul style="list-style-type: none"> ▪ 5-3 ▪ 5-9 ◆ Canopy struts ◆ Bearing MD3614M ◆ Bearing DW4K2X ◆ Nose wheel bearings ◆ Main wheel bearings ◆ Nose fork bushings ◆ Pivot guide ◆ Upper rudder hinge ◆ Lower rudder hinge

GENERAL

WING REMOVAL

No tools or certification required.

■ **CAUTION: BE PREPARED WITH A HELPER OR SUPPORT STAND TO HANDLE THE WEIGHT AND AWKWARDNESS OF THE OBJECT TO BE REMOVED.**

■ **CAUTION: ALWAYS SUPPORT THE FLAPERON DURING WING REMOVAL AND STORAGE.**

1. Retract the fuselage pin stopper on each fuselage pin and withdraw each of them only enough to release the right wing spar. (**Note: rotating the pin back and forth while pulling makes removal easier**).
2. Grasp the wing at the wing tip end, lift very slightly and pull to remove it from the fuselage and set it aside.
3. Fully remove both of the fuselage pins.
4. Remove the left wing using the same procedure and set aside.

● **NOTE: THE OPTIONAL AOA SYSTEM PLUMBING MUST PASS A LEAK TEST DURING EVERY INSPECTION AND EVERY TIME THE WINGS ARE REMOVED AND INSTALLED.**

INSTALLATION

1. Installation procedure is the reverse of the removal procedure. (install left wing first, right wing second). The wing root seal strip on the side of the fuselage can be used to help align the wing at the proper angle of attack while inserting it into the fuselage. The root end of the flaperon must be properly aligned with the clevis portion of the flaperon torque tube for the wing to fully insert. (**Note: rotating the pin while pushing with the heel of your palm helps aid in pin insertion.**)

WING RETENTION PIN BUSHING REPLACEMENT

Tools	Mallet Large wooden dowel, 1 1/2 - 1 3/4 inch dia.
Expendable	None
Replaceable	Wing Retention Pin Bushing
Service Rating	Preventative
Minimum Certification	Owner, LSA-RM, or A&P
Additional References	KAI

1. Remove the wings.

IN CENTER SECTION:

1. Tap out the bushing from the non-flanged end of the bushing.
2. Tap the new bushing into place with the flanged end toward the wing spars.

IN WING SPARS:

3. Tap out the bushing from the non-flanged end of the bushing.
4. Tap the new bushing into place with the flanged end to be on the forward side of the wing spar.

CANOPY AND FRAME REMOVAL

Tools	7/16 socket
Expendable	None
Replaceable	Canopy and Frame Canopy struts
Service Rating	Line
Minimum Certification	LSA-RM or A&P
Additional References	KAI

■ CAUTION: BE PREPARED WITH A HELPER OR SUPPORT STAND TO HANDLE THE WEIGHT AND AWKWARDNESS OF THE OBJECT TO BE REMOVED.

1. Open and support the canopy. (Easiest with a partner)
2. Remove the strut hardware; bolts (2).
3. Remove the pivot hardware; bolts (2), and bushings (2).
4. Remove canopy and frame.

INSTALLATION

■ CAUTION: DO NOT OVERTIGHTEN THE CANOPY STRUT HARDWARE. ALLOW THE CANOPY STRUT APPROXIMATELY 1/64 INCH OF TOTAL MOVEMENT ALONG THE BOLT SHANK.

1. Installation procedure is reverse of the removal procedure.

MAIN WHEEL AND TIRE ASSEMBLY REMOVAL

Tools	Needle nose pliers 1 1/2, 7/16 socket
Expendable	Cotter pins Safety wire
Replaceable	None
Service Rating	Preventative
Minimum Certification	Owner and SPC, LSA-RM, or A&P
Additional References	Matco user manual KAI

1. Lift and support the aircraft. (1-16)
2. Remove the stationary brake shoe bolts (2), washers (2), spacer and brake shoe.
3. Remove the cotter pin, axle nut, washer and wheel and tire assembly.

INSTALLATION

1. Installation procedure is reverse of the removal procedure.

NOSE WHEEL AND TIRE ASSEMBLY REMOVAL

Tools	9/16 socket 9/16 combo wrench
Expendable	None
Replaceable	None
Service Rating	Preventative
Minimum Certification	Owner and SPC, LSA-RM, or A&P
Additional References	Matco user manual KAI

1. Lift and support the aircraft. (1-16)
2. Remove the axle bolt, washers (2), nut, axle, spacer, and wheel and tire assembly.

INSTALLATION

1. Installation procedure is reverse of the removal procedure.

MAIN INNER TUBE REPLACEMENT

Tools	1/2 socket 3/16, 1/4 Allen
Expendable	Inner tube Safety wire
Replaceable	Main wheel assembly Tire
Service Rating	Preventative
Minimum Certification	Owner and SPC, LSA-RM, or A&P
Additional References	Matco user manual KAI

1. Lift and support the aircraft. (1-16)
2. Remove the main wheel and tire assembly. (5-15)
3. Remove the brake disc socket-head cap screws (3), and brake disc.
4. Deflate the inner tube.
5. Split the wheel assembly by removing the socket head cap screws (6), washers (9), and nuts (6).
6. Replace the inner tube. Orient the valve stem to the hole in the wheel and the colored dot on the tire.
7. SLOWLY inflate the tire. Deflate it fully and re-inflate it SLOWLY a couple more times to work out any wrinkles in the tube. Inspect for a good seat around the wheel rim. For final inflation pressure see page 1-14.
8. Reassemble and install the wheel and tire assembly.

NOSE INNER TUBE REPLACEMENT

Tools	3/16 Allen
Expendable	Inner tube
Replaceable	Nose wheel assembly Tire
Service Rating	Preventative
Minimum Certification	Owner and SPC, LSA-RM, or A&P
Additional References	Matco user manual KAI

Lift and support the aircraft. (1-16)

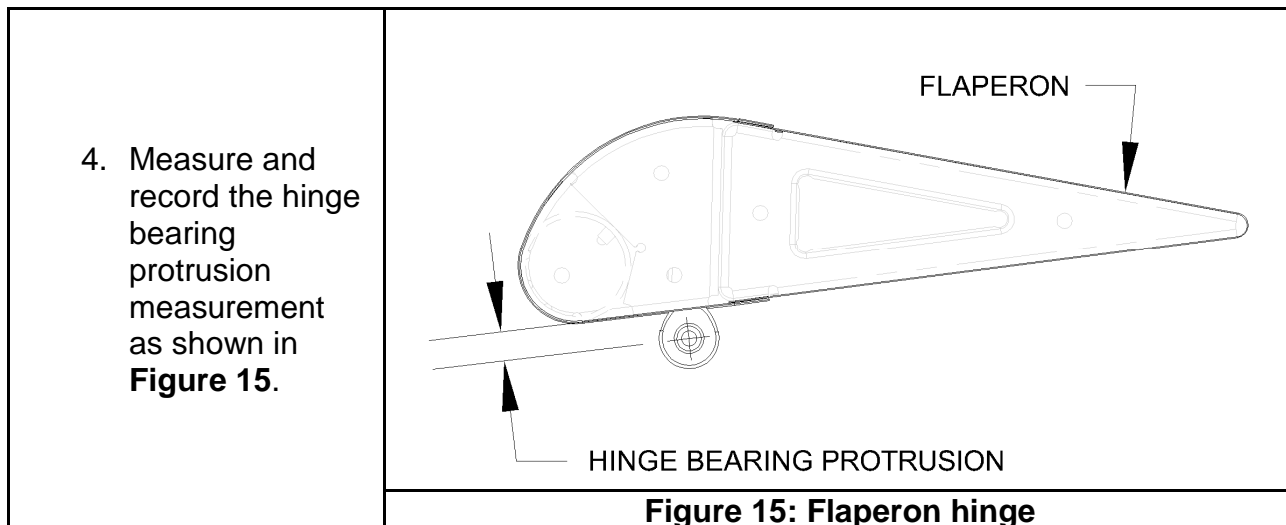
1. Remove the nose wheel and tire assembly. (5-16)
2. Deflate the inner tube.
3. Split the wheel assembly by removing the bolts (3), washers (6), and nuts (3).
4. Replace the inner tube. Orient the valve stem with the hole in the wheel and the colored dot on the tire.
5. SLOWLY inflate the tire. Deflate it fully and re-inflate it SLOWLY a couple more times to work out any wrinkles in the tube. Inspect for a good seat around the wheel rim. For final inflation pressure see page 1-14.
6. Reassemble and install the wheel and tire assembly.

FLAPERON HINGE REPLACEMENT

Tools	3/8 socket 3/8 combo wrench
Expendable	None
Replaceable	Bearing MD3614M
Service Rating	Line
Minimum Certification	LSA-RM or A&P
Additional References	KAI

■ CAUTION: BE PREPARED WITH ADDITIONAL PERSONEL OR TOOLS TO HANDLE THE WEIGHT AND AWKWARDNESS OF THE OBJECT TO BE REMOVED.

1. Remove the wings. (5-13)
2. Make note of the flaperon hinge hardware configuration
3. Remove the flaperon hardware and flaperon assembly.



5. Remove the flaperon hinge bearing from the wing.
6. Install the new flaperon hinge bearing to the same protrusion measurement.
7. Install the flaperon assembly.

RUDDER HINGE REPLACEMENT

Tools	3/8 socket 3/8 combo wrench #2 Phillips screwdriver
Expendable	None
Replaceable	Lower rudder hinge Upper rudder hinge
Service Rating	Line
Minimum Certification	LSA-RM or A&P
Additional References	KAI

■ CAUTION: BE PREPARED WITH ADDITIONAL PERSONEL OR TOOLS TO HANDLE THE WEIGHT AND AWKWARDNESS OF THE OBJECT TO BE REMOVED.

1. Remove the upper and lower tailcone fairing. (3-4)
2. Remove the rudder control cables and rudder assembly.
3. Remove, from the vertical stabilizer, the rudder hinge hardware (see below) and the rudder hinge to be replaced;
 - ◆ Upper hinge; bolt (4), washer (8)
 - ◆ Lower hinge; bolt (4), washer (4)

■ **CAUTION: UPPER AND LOWER RUDDER HINGES ARE NOT INTERCHANGABLE.**

4. Install the new rudder hinge and hardware.
5. Install the rudder assembly.
6. Install the upper and lower tailcone fairing.

STABILATOR HINGE REPLACEMENT

Tools	<p>1/4 drive socket slightly less than 5/8in in diameter. A common standard 7/16 socket generally works.</p> <p>3/8 drive 3/4 socket</p> <p>Screwdriver</p> <p>3/8 Wrench</p> <p>7/16 socket, ratchet and extension</p> <p>Needle nose pliers</p> <p>Hex Bolt 1/4 diameter 3 inches long (must be threaded at least 50% of its length)</p> <p>1/4 Flat Washer(2) and Hex Nut</p>
Expendable	<p>Cotter pins</p> <p>Lock Clips (2)</p> <p>Loctite 648</p>
Replaceable	Bearing DW4K2X
Service Rating	Line
Minimum Certification	LSA-RM or A&P
Additional References	KAI

■ **CAUTION: BE PREPARED WITH ADDITIONAL PERSONEL OR TOOLS TO HANDLE THE WEIGHT AND AWKWARDNESS OF THE OBJECT TO BE REMOVED.**

Removing the Stabilator

1. Remove the upper and lower tailcone fairing. (3-4)

● **NOTE: BEFORE DISCONNECTING THE STABILATOR CONTROL CABLES BE PREPARED TO PREVENT THE ENDS OF THE CABLES FROM FALLING INTO THE TAILCONE.**

2. Remove the two aft most belly inspection covers.

3. Remove the Lock Clips from one of the cable tensioners.
4. Rotate the tensioning barrel to slacken the stabilator control cables.
5. Disconnect the stabilator control cables.
6. Disconnect the aft end of the Trim/Servo Pushrod from the Anti-servo Tabs.
7. Remove the two bolts attaching the counter balance arm to the stabilator.
8. Remove the two bolts attaching the stabilator to the aft end of the tail cone.
9. Remove the stabilator assembly. Note: while extracting the counterbalance arm from the fuselage, rotate the counter balance arm 90 degrees to allow it to pass through the aft tailcone bulkhead.

Bearing Replacement

10. Pressing out the bearing: Position the sockets on each side of the bearing then use the nut, washer and bolt inserted through both sockets and the bearing. Tighten the nut on the bolt to press the bearing towards the large socket. See **Figure 16**.

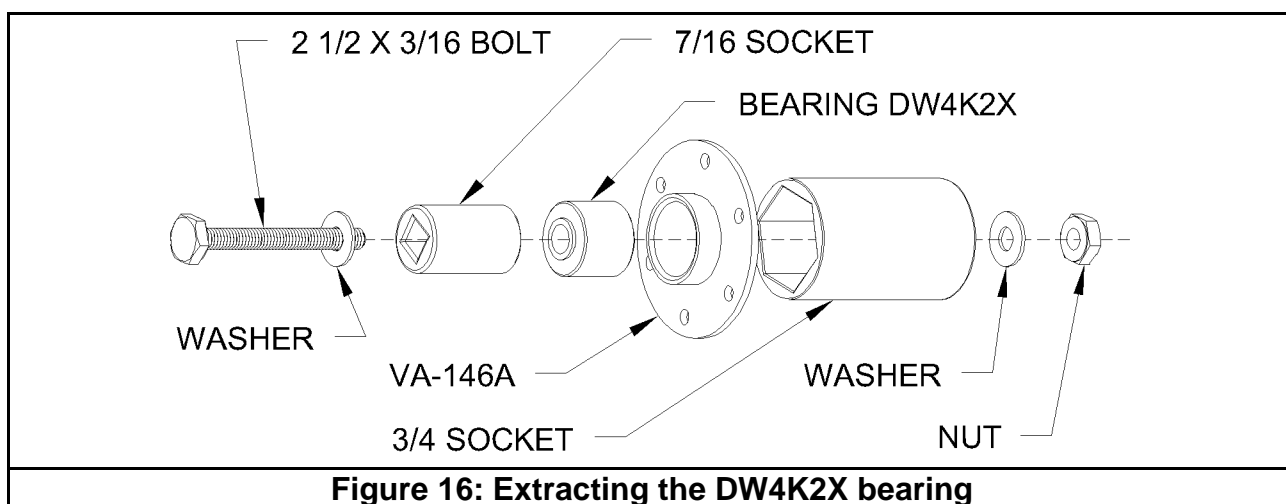


Figure 16: Extracting the DW4K2X bearing

11. Carefully clean the new bearing and the inner bore of the VA-146A Flange Housing using denatured alcohol. After cleaning, handle the bearings with care as to not re-contaminate the outer surface.
12. Insert a bearing into the VA-146A Flange Housing with minimal engagement just far enough that the bearing aligns itself with the center hole in the flange.
13. Place a bead of Loctite 648 onto the outer surface of the bearing around the entire circumference next to the edge of the VA-146A Flange Housing.
14. Pressing in the bearing: Using the same process as removing, use the small socket to press the bearing towards the large socket and into the VA-146A Flange Housing until the bearing is flush on both sides. Allow the Loctite sufficient time to cure per instructions on the package.
15. After reinstalling the stabilator readjust the stabilator control cable tensions in accordance with the KAI and install new lock clips on the adjuster barrel.

■ CAUTION: BE SURE TO RE-ORIENT THE COUNTERBALANCE ARM SO THAT THE COUNTERBALANCE WEIGHT IS POSITIONED CORRECTLY. REFER TO KAI

MAIN GEAR REMOVAL

Tools	7/16, 1/2, 9/16 socket 7/16, 1/2, 9/16 combo wrench
Expendable	Hydraulic fluid
Replaceable	Left Main Gear Right Main Gear Outbd Main Gear Attach Brkt Outbd Wear Plate Inbd Main Gear Attach Brkt Inbd Wear Plate
Service Rating	Line
Minimum Certification	LSA-RM, or A&P
Additional References	KAI Matco user manual

1. Lift and support the aircraft. (1-16)
2. Remove the two outboard center section Cover Plates on the belly. (3-4)
3. Drain the hydraulic fluid. (7-5)
4. Disconnect the brake line at the main gear attach bracket.
5. Remove the center bolt, washer, and nut from the inboard main gear attach bracket.
6. Loosen the remaining inboard and outboard attach bracket hardware.
7. Remove the main gear-leg.

INSTALLATION

1. Installation procedure is reverse of the removal procedure.
2. Add hydraulic fluid and bleed the brake system.
3. Torque all landing gear attach hardware. Remember to account for prevailing torque.

NOSE GEAR REMOVAL

Tools	3/8, 9/16 socket Needle nose pliers
Expendable	Cotter pins
Replaceable	None
Service Rating	Line
Minimum Certification	LSA-RM, or A&P
Additional References	KAI

1. Remove the top and bottom cowl. (3-4)
2. Lift and support the aircraft. Place an additional support stand at the tail tie down. (1-16)

▲ WARNING: DO NOT REMOVE THE UPPER VIBRATION-ISOLATOR BOLTS.

3. Remove the lower engine vibration-isolator bolts (2).
4. Remove the nose gear-leg hardware from the fuselage; bolts (13) and washers (13).

● NOTE: THE ENGINE CAN BE LIFTED BY HAND AT THE GEARBOX.

5. Lift the front of the engine only enough to remove the engine weight from the gear-leg bracket.
6. Remove the nose gear-leg.

INSTALLATION

1. Lift the front of the engine only enough to provide room behind the engine mount for the nose gear-leg.
2. Install the nose gear-leg and attach hardware.
3. Install the lower engine vibration isolator bolts.

BELT AND HARNESS REPLACEMENT

Tools	7/16 socket 7/16 combo wrench
Expendable	None
Replaceable	Occupant Harness
Service Rating	Preventative
Minimum Certification	Owner and SPC, LSA- RM, or A&P
Additional References	KAI

▲ WARNING: HARNESS PARTS THAT SHOW ANY SIGN OF WEAR REQUIRE THAT THE ENTIRE HARNESS SET BE REPLACED IMMEDIATELY.

1. Remove the seat ramp cover. (3-4)
2. Remove the crotch strap; bolt, bushing, washer, nut.
3. Remove each waist strap (2); bolt, bushing, washer, nut.
4. Remove the shoulder straps; bolt, bushing, washer, nut.
5. Install the new harness set and attach hardware.

CANOPY LATCH BLOCK REPLACEMENT

Tools	#2 Phillips screwdriver
Expendable	None
Replaceable	Latch Block
Service Rating	Line
Minimum Certification	LSA-RM, or A&P
Additional References	KAI

1. Remove the latch block attach screws (2) and the latch block.
2. Install the new latch block and attach hardware.

STEP REPLACEMENT

Tools	7/16 socket
Expendable	None
Replaceable	Left or Right Step
Service Rating	Preventative
Minimum Certification	Owner, LSA-RM, or A&P
Additional References	KAI

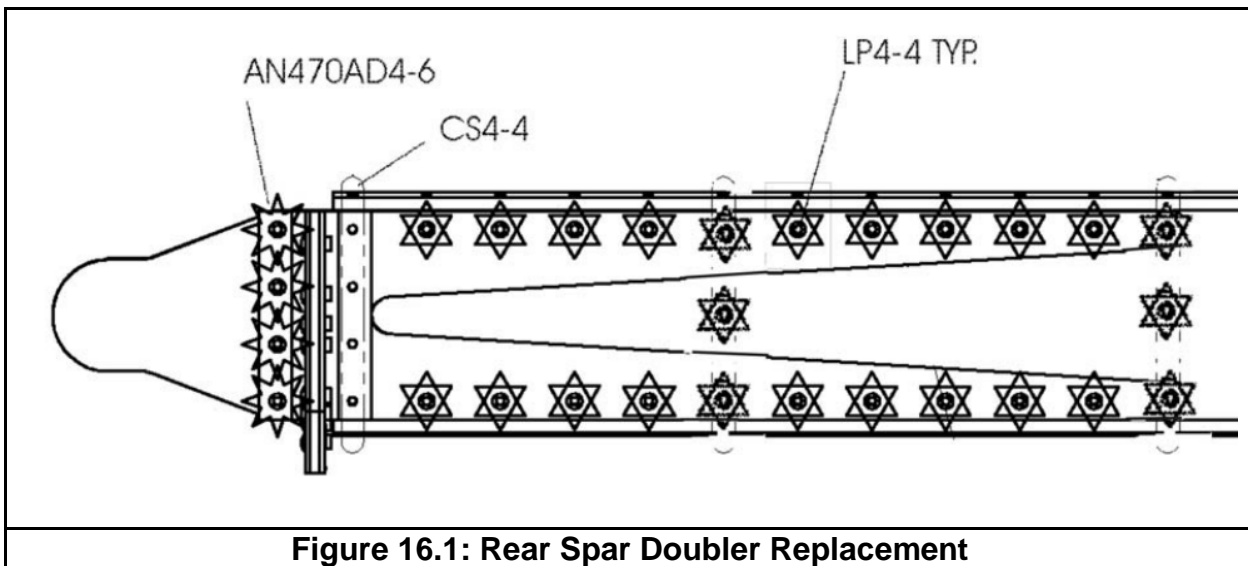
1. Remove the step attach bolts (2), washers (2) and the step.
2. Install the new step and attach hardware.

REAR SPAR DOUBLER REPLACEMENT

Tools	#30 drill bit, drill, cecos, rivet puller, rivet squeezer & dies
Expendable	sandpaper
Replaceable	Left or Rt. Rear Spar Doubler
Service Rating	Line
Minimum Certification	LSA-RM, or A&P
Additional References	KAI

1. Based on the measurement from Section 3, Inspection, chose one of the replacement W-1207B-x rear spar doublers. There are four different ones available, ranging from 0.025 to 0.055 longer than the original, in increments of 0.010 — (i.e: W-1207-25 is 0.025” longer than stock.) Note that a pattern of holes punched in the inboard end indicates the size – one extra hole is the first oversize then two, three and four holes are used to identify each progressively longer part.
2. Prepare the doubler by sanding the rounded end just enough to remove the rough surface left from manufacture, no more.
3. Prime the doubler if/as desired.
4. Remove the wing and drill out the rivets attaching the W-1207B rear spar doubler, W-1212 and hinge assembly to the rear spar. See KAI Section 5.4.

5. Drill the holes in the new doubler to #30 (except the identifier holes) and cleco it to the rear spar.
6. Test fit the wing with the new doubler clecoed in place (the hinge assembly does not need to be in place for this step.) If the fit is too tight, remove the wing, un-cleco the doubler and sand the contour of the curve 0.010" or less and test fit again. Repeat until the correct fit is achieved.
7. Rivet the doubler and hinge assembly to the spar as shown below



SERVICE SCHEDULE PROCEDURES

WING ATTACH LOCATION LUBRICATION

(WINGS REMOVED)

Tools	None
Expendable	Wheel bearing grease Anti-seize compound
Replaceable	Fuselage Pin
Service Rating	Preventative
Minimum Certification	Owner and SPC, LSA-RM, or A&P
Additional References	KAI

FUSELAGE PINS

1. Wipe clean, the fuselage pins (2).
2. Wipe clean, the wing retention pin bushings (8).
3. Apply grease lubricant sparingly to the shaft of each fuselage pin.

STUB SPAR AND REAR SPAR

1. Wipe clean, the inboard end of the stub spar and rear spar of each wing. (5-4)
2. Apply anti-seize compound sparingly to the inboard end of the stub spar and rear spar of each wing.

FLAPERON CONTROL CONNECTION LUBRICATION

(WINGS REMOVED)

Tools	None
Expendable	Wheel bearing grease
Replaceable	None
Service Rating	Preventative
Minimum Certification	Owner and SPC, LSA-RM, or A&P
Additional References	KAI Wing removal (5-13)

1. Wipe clean, the UHMW pivot guide and actuation bracket of each flaperon. **See page 5-4, Figure 10.**
2. Apply lubricant sparingly to the UHMW pivot guide and actuation bracket of each flaperon.

FLAPERON BEARINGS LUBRICATION

Tools	None
Expendable	Spray lubricant
Replaceable	None
Service Rating	Preventative
Minimum Certification	Owner and SPC, LSA-RM, or A&P
Additional References	KAI Flaperon hinge replacement (5-17)

1. Wipe away any dirt accumulation from each of the flaperon bearings (3).
2. Apply lubricant sparingly to each of the flaperon bearings.
3. Allow lubrication to penetrate for a minute or more. Wipe away excess.

ANTI-SERVO TAB ATTACH HINGE LUBRICATION

Tools	None
Expendable	Spray lubricant
Replaceable	None
Service Rating	Preventative
Minimum Certification	Owner and SPC, LSA-RM, or A&P
Additional References	KAI

1. Lower the Anti-Servo Tab by adjusting the trim. Lower the trailing edge of the stabilator.
2. Wipe away any dirt accumulation from the AST attach hinges.
3. Apply lubricant along the top of the left and right AST attach hinges.
4. Allow lubrication to penetrate for a minute or more. Wipe away excess.

NOSE WHEEL BEARINGS REPLACEMENT

■ CAUTION: THE NOSE WHEEL BEARINGS ARE NOT SERVICEABLE PARTS.

Tools	3/16 Allen Small wooden dowel, 1/2 - 1 inch dia. Mallet
Expendable	None
Replaceable	Wheel bearings
Service Rating	Preventative
Minimum Certification	Owner, LSA-RM, or A&P
Additional References	Matco user manual

1. Lift and support the aircraft. (1-16)
2. Remove the nose wheel and tire assembly. (5-16)
3. Deflate the inner tube.

4. Split the wheel and tire assembly by removing the bolts (3), washers (6), and nuts (3).
5. Press the wheel bearing out from the inside of each wheel half.
6. Press a new wheel-bearing into each wheel half.
7. Reassemble the wheel and tire assembly.
8. SLOWLY inflate the tire. Deflate it fully and re-inflate it SLOWLY a couple more times to work out any wrinkles in the tube. Inspect for a good seat around the wheel rim. The final inflation pressure is 15 psi.
9. Install the wheel and tire assembly.

MAIN WHEEL BEARINGS LUBRICATION

Tools	1 1/2 socket Needle nose pliers
Expendable	Wheel bearing grease
Replaceable	Wheel bearing
Service Rating	Preventative
Minimum Certification	Owner and SPC, LSA-RM, or A&P
Additional References	Matco user manual

1. Lift and support the aircraft. (1-16)
2. Remove the main wheel and tire assembly.
3. Remove and clean the main wheel bearings (2).
4. Apply wheel-bearing grease to each of the bearings.
5. Install the wheel-bearings.
6. Install the wheel and tire assembly.

NOSE FORK PIVOT TENSION AND LUBRICATION

Tools	Needle nose pliers 1 1/2 socket Tensile weight scale
Expendable	Waterproof wheel bearing grease
Replaceable	Nose fork bushings
Service Rating	Line
Minimum Certification	LSA-RM, or A&P
Additional References	KAI

1. Lift and support the aircraft. (1-16)
2. Remove the nose fork and attach hardware; cotter pin, nut, washer, spring washers (2).
3. Clean the end of the nose gear leg and the nose fork bushings.
4. Apply a liberal amount of marine trailer (or waterproof equivalent) wheel bearing grease to the nose fork bushings.
5. Installation procedure is reverse of the removal procedure.
6. Tighten the nut until a push or pull force of 18-20 lbs applied at the axle is measured while the nose fork is rotated around the end of the nose gear leg.

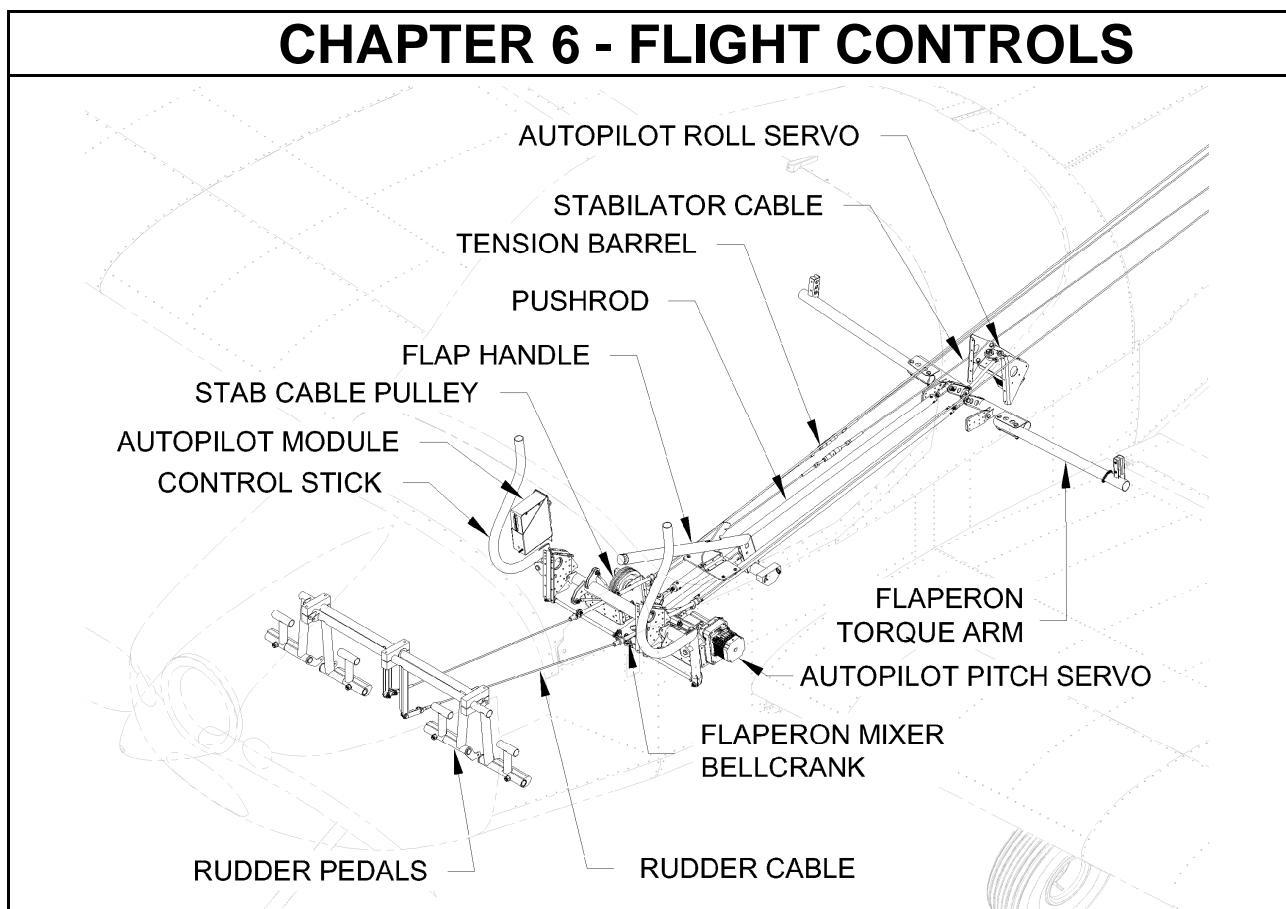
TIRE ASSEM. BALANCING PROCEDURE

• NOTE: IT IS NOT A MAINTENANCE REQUIREMENT THAT THE NOSE OR MAIN WHEEL/TIRE ASSEMBLIES ON THE RV-12 BE BALANCED, BECAUSE OF THE RELATIVELY LOW TAKEOFF AND LANDING SPEED. SHOULD A VIBRATION BE DETECTED THAT IS SUSPECTED TO BE CAUSED BY A WHEEL/TIRE IMBALANCE, THIS PROCEDURE MAY BE USED.

1. Remove the suspected out of balance wheel/tire assembly(s) from the aircraft.
2. Mount the Wheel/Tire assy. in a static balance test stand and allow the assy. to rotate to the heavy side down position.
3. A.) Main Wheel assy. - Use tape to temporarily add stick on wheel weights (obtain from a local automotive store commonly available wheel weights with self-adhesive) to the outboard wheel flange, opposite the heavy point of the wheel, until the assy. can be moved to any rotational position without it rotating. Mark the position of the wheel weights and then remove them. Thoroughly clean the area of the wheel flange where the wheel weights will be located. Remove the protective backing and press the wheel weights in place on the wheel flange.
B.) Nose Wheel assy. - Use tape to temporarily add stick on wheel weights to the interior area of the nose wheel (working through the lightening holes in the wheel). If the proper weight location coincides with one of the three wheel through bolts, distribute the weight, as close as possible, to each side of the through bolt. Thoroughly clean the interior area of the wheel where the wheel weights will be located. Remove the protective backing and press the wheel weights in place on the interior area of the wheel.
4. Re-install the wheel assy. on the aircraft.

THIS PAGE INTENTIONALLY LEFT BLANK

CHAPTER 6 - FLIGHT CONTROLS



OVERVIEW	6-2
Components	6-2
SERVICE	6-3
Supplies	6-3
Tools	6-3
Expendable	6-3
Replaceable	6-3
General	6-3
Stabilator pulley replacement and cable tension adjustment	6-3
Control cable replacement	6-6
Rod end replacement	6-7
Bellcrank bearing replacement	6-8
Rudder pedal removal	6-8
Installation	6-9
Service Schedule Procedures	6-9
Control system rod end lubrication	6-9
Cable end hardware lubrication	6-9

OVERVIEW

The control system enables the pilot to operate the control surfaces. Forward or aft movements of the control stick control the pitch. The pitch control linkage is a pair of cables, each routed around a pulley. An electronic switch wired to the pitch-trim servo, controls the pitch-trim. Side-to-side movements of the control stick controls roll via push rods, a bell crank, and torque tubes. Rudder pedals control yaw via cables to the rudder.

Refer to the KAI to identify the individual parts and part #'s of the control system.

• **NOTE: This maintenance manual is intended to be used in conjunction with the RV-12 Kit Assembly Instructions (KAI) when completing maintenance or repair processes.**

COMPONENTS

Quantity	Part or Assembly Name	Part Number or Reference
1	Flap handle / Pushrod	Refer to KAI
1	Flaperon Mixer Bellcrank	F-1263A & F-1263B
2	Control stick pushrod	Refer to KAI
2	Control stick	WD-1212
2	Flaperon pushrod	Refer to KAI
1	Left flaperon torque arm	Refer to KAI
1	Right flaperon torque arm	Refer to KAI
2	Stabilator cable	F-1247A & B
2	Rudder cable	F-1239
2	Rudder pedal	WD-1206
2	Stab cable pulley	MS24566-4B
4	Locking clips	MS21256-1
1	Pitch / Trim servo	See Chapter 8
	Optional Components	
1	Autopilot Module	IF Dynon AP AP74V-12 or SV-AP-PANEL and SV-KNOB-PANEL or Garmin GMC 305
1	Autopilot (Pitch) Servo	IF DYNON AP SV32 or Garmin GSA 28
1	Autopilot (Roll) Servo	IF DYNON AP SV32 or Garmin GSA 28

SERVICE

Annual lubrication will maximize the longevity of the control system. Refer to the service schedule checklist for the specific service frequency of the components. See Supplement for *service schedule checklist*.

SUPPLIES

TOOLS	EXPENDABLE
<ul style="list-style-type: none"> ◆ Needle nose pliers ◆ Socket: <ul style="list-style-type: none"> ▪ 11/32 ▪ 3/8 ▪ 7/16 ▪ 3/4 ▪ 11 mm ◆ Combination wrench: <ul style="list-style-type: none"> ▪ 3/8 ▪ 7/16 ◆ Screwdriver: <ul style="list-style-type: none"> ▪ #2 Phillips ◆ 2 1/2x3/16 bolt, washer, and nut ◆ Cable tension meter ◆ Spring clamps (3) ◆ Stick, 41" long 	EXPENDABLE
	<ul style="list-style-type: none"> ◆ Cotter pins ◆ Safety wire ◆ Spray lubricant
	REPLACEABLE
	<ul style="list-style-type: none"> ◆ Stabilator pulley ◆ Lock clips ◆ Stabilator cables ◆ Rudder cables ◆ Bearing #DW4K2X (Bellcrank) ◆ Rod ends: <ul style="list-style-type: none"> ▪ Control Stick: M3414 / CM-4MS ▪ Flap Handle: CM-4M ▪ Flaperon: F3514M ▪ Trim/Servo: MM-3 ◆ Rudder pedal

GENERAL

STABILATOR PULLEY REPLACEMENT AND CABLE TENSION ADJUSTMENT

Tools	3/8, 7/16 socket 3/8, 7/16 combo wrench Needle nose pliers Cable tension meter Spring clamps (3) Stick, 41" long
Expendable	Cotter pins, Lock clips
Replaceable	Stabilator pulley
Service Rating	Line
Minimum Certification	LSA-RM, or A&P
Additional References	KAI

1. Remove the seat ramp cover and cover plate (only the aft two). (3-4)

2. Remove the stabilator control cable barrel lock clips from one barrel as shown in **Figure 17**.

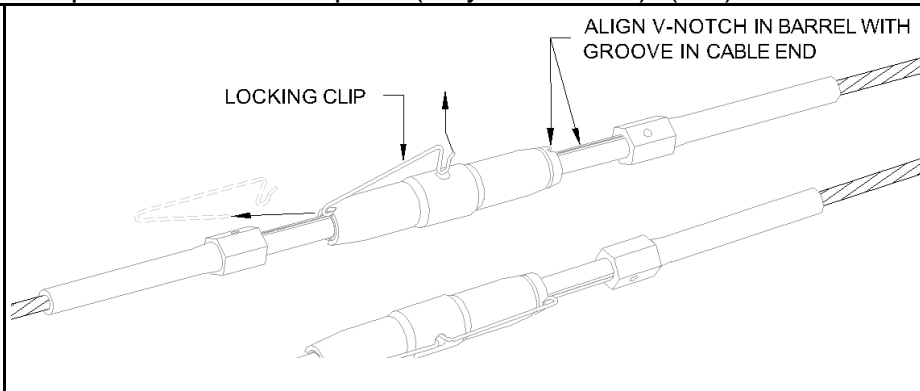


Figure 17: Locking clip removal

3. Loosen the tension of the stabilator cables by turning the tensioner barrel as shown in **Figure 18**.

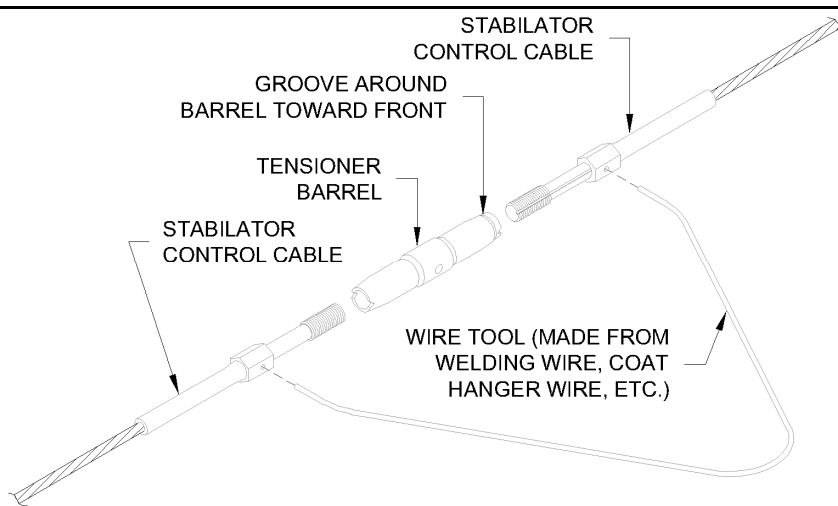


Figure 18: Tensioner barrel removal

4. Remove the pulley axle hardware and pulleys.
5. Capture the stabilator cables between the bushing and the new pulleys.
6. Install the pulley axle hardware.
7. Place a small weight on the stabilator to hold it trailing edge down. Remove the slack from the upper cable by tightening the upper (outboard) turnbuckle until the control stick and stabilator just start to lift off the stops at about the same time when the stick is moved aft.

Remove the slack from the other cable by adjusting the lower (inboard) turnbuckle. Check the entire length of the cables to ensure they are free from interference, are properly aligned in the pulleys, and do not touch each other. Pull the stick aft to make sure that the stabilator trailing edge moves up.

NOTE: The F-1227 Seat Ramp Cover must be installed prior to adjusting the cable tension.

8. Install the F-1227 Seat Ramp Cover (refer to KAI). If the four screw holes for the F-1233 Control Column Mount Brackets (refer to KAI) do not align with the cover, a light upward pull on the stick will correct the misalignment until the screws are inserted and tightened.

NOTE: Cable tension will change significantly with changing temperature. The cable tensions given below are for an aircraft inside a 70 °F hanger.

9. Position one of the WD-1212 Control Sticks so that the top end is 10 inches from the instrument panel. Secure the control stick in place using a spring clamp to attach it to a 41" long stick bridged between and clamped to the upper longerons.

Check the cable tension just aft of the F-1207B Baggage Bulkhead using a calibrated cable tension meter making sure the control stick is correctly positioned.

Adjust turnbuckles an equal number of turns each to achieve 35-45 lbs of tension with the groove in the cable ends aligned with a V-notch in each turnbuckle barrel as shown in Figure 17. This tension will prevent the cables from "slapping" against the tailcone bulkheads when the control sticks are moved suddenly and repeatedly forward then aft.

10. Remove the clamp and stick from the control stick and the weight from the stabilator.

Move the control stick between the forward and aft pitch stops. The stabilator should reach its travel stops just before the corresponding control stick stops are reached. If not, adjust the turnbuckles an equal and opposite number of turns until this is achieved. (Example: If the stabilator reaches its T.E. up stop too soon loosen the upper turnbuckle and tighten the lower turnbuckle. This will lengthen the upper cable and shorten the lower cable). After making adjustments repeat step 6 to reconfirm proper cable tension.

11. Once the proper tension is achieved, and no more than three threads are exposed from the ends of the barrels, align the V-notch in the ends of the barrel with the groove in the cable ends and then insert the lock clips as shown in Figure 17. The hook end of the lock clips are inserted into the hole in the center of the barrel and must be completely pressed in until the hook springs open inside the barrel.

CONTROL CABLE REPLACEMENT

■ **CAUTION: THE CONTROL SURFACE WILL SWING FREELY WHEN THE CONTROL CABLES ARE REMOVED.**

● **NOTE: ALWAYS REPLACE CONTROL CABLES AS A SET.**

Tools	3/8, 7/16 socket 3/8, 7/16 combo wrench Needle nose pliers String Cable tension meter Spring clamps (3) Stick, 41" long
Expendable	Cotter pins Lock clips
Replaceable	Stabilator cables Rudder cables
Service Rating	Line
Minimum Certification	LSA-RM, or A&P
Additional References	KAI

1. Remove the tunnel cover, step floor cover, seat ramp cover, seat floor cover, cover plate (only the aft two), baggage cover, baggage bulkhead corrugation, upper tailcone fairing, lower tailcone fairing, fuel tank assembly. (3-4)
2. **For rudder cable**, remove the rudder cable sleeve attach hardware; bolts (3), washers (3), nuts (3).
3. **For the stabilator cable**, remove the tensioner barrels and stabilator pulleys. (6-4)

● **NOTE: TIE A STRING, LONGER THAN THE CONTROL CABLE, TO THE AFT END OF THE CONTROL CABLE AND WRAP THE SAME END OF THE CONTROL CABLE WITH A PIECE OF TAPE TO AVOID BULKHEAD DAMAGE.**

4. Disconnect the attach hardware (see below) at the forward and aft end of the cable to be removed.

Rudder cable end hardware:
Fwd; bolt, washer, nut, and cotter pin.
Aft; bolt, washers (3), nut, and cotter pin.

Stabilator cable end hardware:
Fwd; bolt, washer (2), nut, and cotter pin.
Aft; bolt, washers (3), nut, and cotter pin.
5. Pull the cable out from the opposite end of the string. Remove the cable, leaving the string in its place.
6. Tie the new cable to the end of the string and cover the end with a piece of tape.

● **NOTE: THE SEAT RAMP COVER MUST BE INSTALLED PRIOR TO ADJUSTING THE CABLE TENSION.**

7. Installation procedure is reverse of the removal procedure.
8. Adjust cable tension as described earlier in this chapter.

ROD END REPLACEMENT

Tools	3/8, 7/16 socket 3/8, 7/16 combo wrench
Expendable	Cotter pins
Replaceable	Applicable rod end
Service Rating	Line
Minimum Certification	LSA-RM, or A&P
Additional References	KAI

1. Remove applicable combination of the seat ramp cover, seat floor cover, baggage cover, and fuel tank assembly. (3-4)
2. Remove the control rod attach hardware from the rod end for replacement;
 - Control stick – control stick pushrod:** bolt, washers (3), and nut.
 - Control stick pushrod – bellcrank:** washer and nut.
 - Bellcrank – flap handle pushrod:** bolt and washers (2).
 - Bellcrank – flaperon pushrod:** bolt, washer and nut.
 - Flaperon pushrod – flaperon torque arm:** bolt, washers (2) and nut.
3. Make note of the number of threads exposed on the rod end shaft and the clocking of the bearing body.
4. Remove the rod end and jam nut.
5. Add a jam nut to the new rod end shaft.
6. Install the new rod end to the position (from step 3) of the original rod end.
7. Install the control rod and control rod attach hardware.

BELLCRANK BEARING REPLACEMENT

Tools	3/8, 7/16, 3/4, 11 mm socket 3/8, 7/16 combo wrench 2 1/2x3/16 bolt, washer, and nut
Expendable	None
Replaceable	Bearing DW4K2X
Service Rating	Line
Minimum Certification	LSA-RM, or A&P
Additional References	KAI

1. Remove the seat ramp cover and seat floor cover. (3-4)
2. Remove the pushrod-to-bellcrank hardware:
Control stick pushrod: washer and nut
Flap handle pushrod: bolt and washers (2)
Flaperon pushrod: bolt, washer and nut
3. Remove the bellcrank.
4. Use the same method instructed for extracting the DW4K2X hinge bearing on **page 5-20, Figure 16.**
5. Installation procedure is reverse of the removal procedure.

RUDDER PEDAL REMOVAL

Tools	1 1/32, 3/8 socket 3/8 combo wrench Needle nose pliers #2 Phillips screwdriver
Expendable	Cotter pins
Replaceable	Rudder pedal
Service Rating	Line
Minimum Certification	LSA-RM, or A&P
Additional References	KAI Matco user manual

1. Remove the tunnel cover. (3-4)
2. Remove the rudder pedal access covers (directly aft of the horizontal tubes of the rudder pedals) and hardware; screws (3), washers (2) and nuts (2).

● **NOTE: THE MASTER CYLINDERS CAN BE REMOVED WITHOUT DISCONNECTING THE BRAKE LINES.**

3. Label, and then remove the master cylinders (4) from the rudder pedals. (7-3)
4. Remove the rudder cable hardware from each rudder cable; cotter pin, bolt, washers (3) and nut.

5. Remove the rudder pedal-block hardware; bolts (2) and washers (2), from each of the rudder pedal-blocks (3).
6. Remove rudder pedal assembly.

INSTALLATION

1. Installation procedure is reverse of the removal procedure.

SERVICE SCHEDULE PROCEDURES

CONTROL SYSTEM ROD END LUBRICATION

Tools	#2 Phillips 3/8, 7/16 sockets
Expendable	Spray lubricant
Replaceable	None
Service Rating	Line
Minimum Certification	LSA-RM, or A&P
Additional References	KAI

1. Remove the seat ramp cover, seat floor cover, baggage cover, and fuel tank assembly. (3-4)
2. Apply lubricant sparingly to the rod-end bearings on each end of the following components:
 - ♦ Flap handle pushrod
 - ♦ Control stick pushrod
 - ♦ Flaperon pushrod
 - ♦ Trim / Servo pushrod
3. Allow lubrication to penetrate then wipe away excess.
4. Apply grease to F-1266AD Flap Detent Bracket.

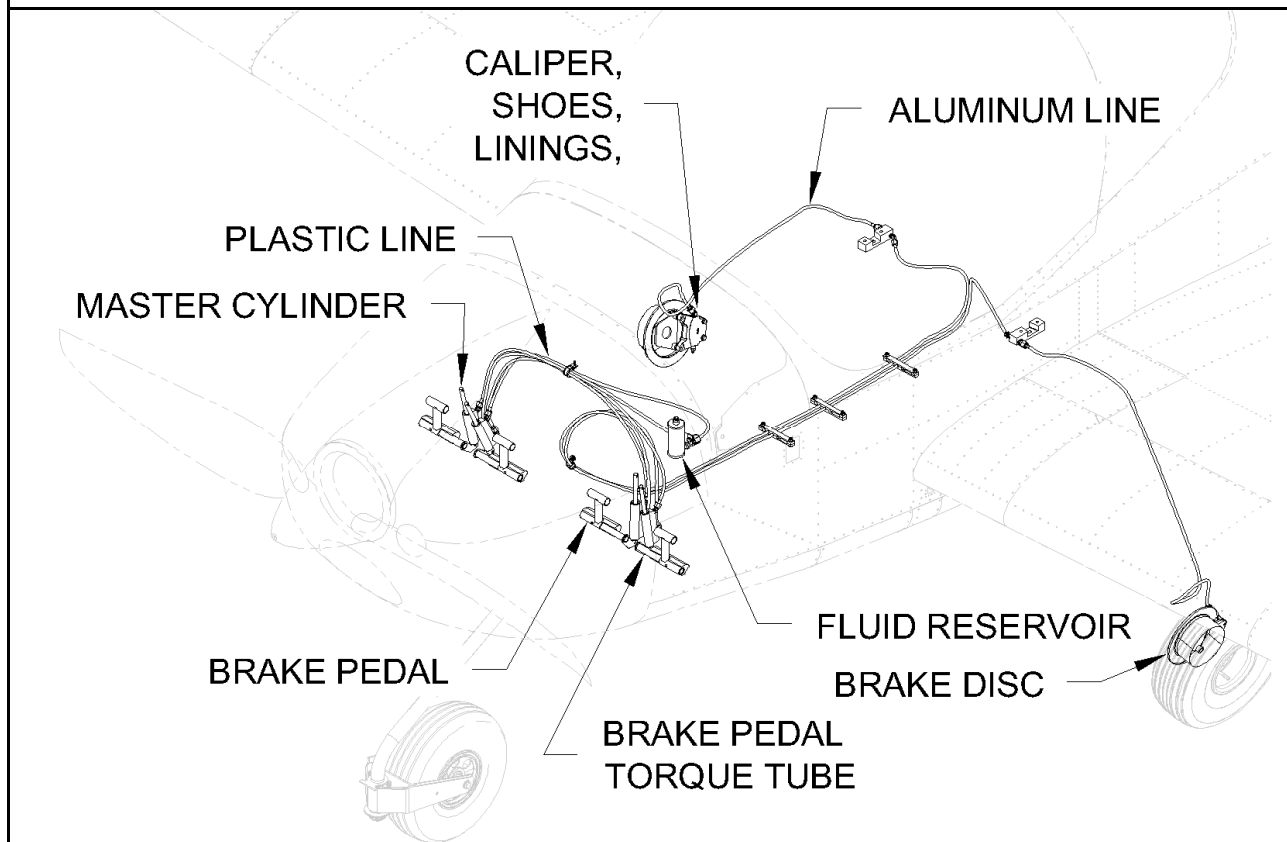
CABLE END HARDWARE LUBRICATION

Tools	None
Expendable	Spray lubricant
Replaceable	None
Service Rating	Line
Minimum Certification	LSA-RM, or A&P
Additional References	KAI

1. Remove the tunnel cover, seat ramp cover, upper tailcone fairing, and lower tailcone fairing. (3-4)
2. Apply lubricant sparingly to the hardware at both ends of the rudder and stabilator control cables.

THIS PAGE INTENTIONALLY LEFT BLANK

CHAPTER 7 - BRAKE SYSTEM



OVERVIEW	7-2
Components	7-2
SERVICE	7-2
Supplies	7-3
Tools	7-3
Expendable	7-3
Replaceable	7-3
General	7-3
Master cylinder removal	7-3
Removal	7-3
Disconnection	7-4
Installation	7-4
Service Schedule Procedures	7-4
Brake pedal torque tube lubrication	7-4
Hydraulic fluid drain, flush, and replace	7-5
Draining	7-5
Flushing	7-5
Replacing	7-5
Brake lining replacement	7-6

OVERVIEW

The brake system includes the necessary components to provide directional control and stopping ability while taxiing. The left and right brakes are independently controlled hydraulic disc brakes. The fluid reservoir supplies the master cylinders with hydraulic fluid. Pressure applied to either brake pedal causes the master cylinder to force hydraulic fluid through the plastic and aluminum lines to the corresponding brake caliper.

Refer to the Matco instructions and the KAI to identify the individual parts of the brake system.

• **NOTE: This maintenance manual is intended to be used in conjunction with the RV-12 Kit Assembly Instructions (KAI) when completing maintenance or repair processes.**

COMPONENTS

Quantity	Part or Assembly Name	Part Number or Reference
2	Disc and caliper	Matco; Refer to KAI
4	Brake shoes	Refer to Matco manual
4	Brake shoe linings	Refer to Matco manual
4	Brake pedal	WD-1209
2-L,2-R	Brake pedal torque tube	WD-1211-L & R
2	Left brake master cylinder	BRAKE MAST CYL LEFT-1
2	Right brake master cylinder	BRAKE MAST CYL RIGHT-1
1	Fluid Reservoir	VA-107
2	Aluminum Line	Refer to KAI
6	Plastic Line	Refer to KAI

SERVICE

Use of the proper hydraulic fluid is necessary for proper operation of the brake system. It is good practice to replace the hydraulic fluid every 5 years. If any indication of contamination is present, replace hydraulic fluid as soon as possible. Since the brakes on the RV-12 are relied on for part of the airplanes steering control on the ground, any detected leaks should be repaired prior to further flight. Refer to the *service schedule checklist* for component service frequency.

SUPPLIES

■ **CAUTION: USE ONLY MIL SPEC MIL-H-5606A HYDRAULIC FLUID! DO NOT USE AUTOMOTIVE BRAKE FLUID. DAMAGE TO O-RING SEALS MAY RESULT.**

TOOLS	EXPENDABLE
<ul style="list-style-type: none"> ◆ Socket: <ul style="list-style-type: none"> ▪ 3/8 ▪ 7/16 ◆ Combination Wrench: <ul style="list-style-type: none"> ▪ 1/4 ▪ 3/8 ▪ 7/16 ▪ 1/2 ◆ Needle nose pliers ◆ Container 	<ul style="list-style-type: none"> ◆ Hydraulic fluid ◆ Wheel bearing grease ◆ Cotter pins ◆ Brake shoe linings
	REPLACEABLE
	<ul style="list-style-type: none"> ◆ See component list on page 7-2.

GENERAL

MASTER CYLINDER REMOVAL

■ **CAUTION: THE LEFT AND RIGHT MASTER CYLINDERS ON EACH SIDE OF THE AIRCRAFT ARE NOT INTERCHANGABLE.**

Tools	3/8 socket 3/8, 1/2 combo wrench Needle nose pliers
Expendable	Hydraulic fluid Cotter pins
Replaceable	Left/Right Brake master cylinder
Service Rating	Line
Minimum Certification	LSA-RM, or A&P
Additional References	KAI Matco user manual

REMOVAL

1. Remove the upper and lower master cylinder attach hardware.
 - Upper:** clevis pin, washer, and cotter pin.
 - Lower:** bolt, washer, nut, and cotter pin.

DISCONNECTION

1. Drain the hydraulic fluid. (7-5)
2. Make note of the hose connections.
3. Disconnect brake lines from master cylinder.

INSTALLATION

1. Installation procedure is reverse of the removal procedure.
2. Bleed the brake system. (7-5)

SERVICE SCHEDULE PROCEDURES

BRAKE PEDAL TORQUE TUBE LUBRICATION

Tools	7/16 socket 7/16 combo wrench Needle nose pliers
Expendable	Cotter pins Wheel bearing grease
Replaceable	None
Service Rating	Line
Minimum Certification	LSA-RM, or A&P
Additional References	KAI

• **NOTE: SERVICE ONE PEDAL AT A TIME.**

<ol style="list-style-type: none"> 1. Actuate the rudder pedals so that the brake pedal to be serviced is offset from the adjacent rudder and brake pedal. The following steps relate to Figure 19. 2. Remove the master cylinder lower hardware. 3. Remove the brake pedal hardware; bolt, washer, and nut. 	<p>The diagram shows a mechanical assembly for a rudder pedal. A long horizontal bar labeled 'RUDDER PEDAL' is connected to a vertical shaft labeled 'WD-1209'. This shaft is secured with a 'WASHER' and a 'NUT'. Below this, another vertical shaft is labeled 'WD-1211-L' and is secured with a 'NUT' and a 'COTTER PIN'. A 'WASHER' is also shown. A 'LUBRICATE HERE' label points to a joint in the assembly. At the bottom, a 'BRAKE MAST CYL LEFT-1' is connected to the assembly via a 'BOLT' and another 'BOLT'.</p>
Figure 19: Torque tube lubrication	

4. Remove the brake pedal from the pivot tube.
5. Remove the pivot tube from the rudder pedal.
6. Clean the pivot tube then apply lubricant to the exterior of the tube.
7. Installation procedure is reverse of the removal procedure.

HYDRAULIC FLUID DRAIN, FLUSH, AND REPLACE

Tools	1/4, 7/16 combo wrench Container
Expendable	Hydraulic fluid
Replaceable	None
Service Rating	Line
Minimum Certification	LSA-RM or A&P
Additional References	KAI Matco user manual

DRAINING

1. Place suitable containers beneath each brake caliper to capture hydraulic fluid from each bleeder valve.
2. Open the bleeder valve on each brake caliper and allow fluid to drain.

FLUSHING / REPLACING

1. Install a clear hose on the top of the brake fluid reservoir and insert it in a container to catch fluid overflow.
2. Attach a pump style oil can filled with hydraulic fluid to the bleeder valve on the bottom of one of the brake calipers. Open the bleeder valve and pump the oil can until clean fluid flows in the clear tube at the top of the fluid reservoir. Close the bleeder valve and remove the oil can and hose.
3. Repeat the previous step on the other brake caliper.
4. Confirm that the brake peddle at each seat position for the left and right brake systems feel firm with no sponginess when pressed. Also confirm that there are no air bubbles visible in the translucent brake lines between the left and right seat rudder pedals. If there is any sponginess or presence of air bubbles repeat the flushing / replacing steps.
5. Use a syringe to slightly reduce the fluid level in the reservoir and reinstall the reservoir cap.

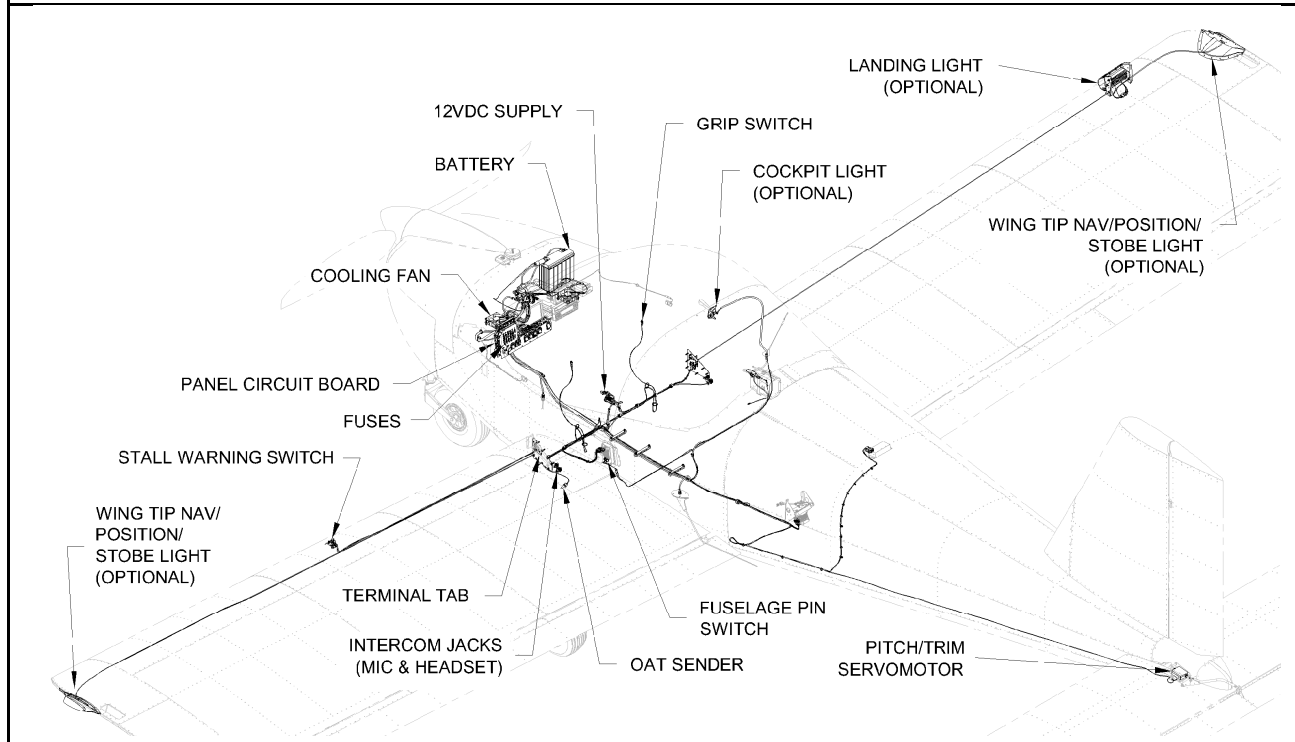
BRAKE LINING REPLACEMENT

• **NOTE: IT IS RECOMMENDED TO REPLACE ALL OF THE BRAKE LININGS ON BOTH SIDES EVEN IF ONLY ONE LINING REQUIRES REPLACEMENT.**

Tools	7/16 socket
Expendable	Brake linings Safety wire
Replaceable	Brake disc
Service Rating	Line
Minimum Certification	LSA-RM or A&P
Additional References	KAI Matco user manual

1. Remove the 2 safety wired bolts and remove the stationary brake shoe.
2. Remove the brake housing from the brake plate (use care to not damage the aluminum brake line)
3. Remove the floating brake shoe.
4. Check that the brake disc is within wear limits. Replace if necessary.
5. Install new linings on the brake shoes per Matco instructions.
6. Install the floating brake shoe.
7. Install the brake housing on the brake plate.
8. Install the stationary brake shoe and safety wire the bolts.
9. Test for proper brake system operation. Check the hydraulic fluid level.

CHAPTER 8 - ELECTRICAL SYSTEM



OVERVIEW	8-2
Components	8-2
Optional Lighting	8-3
Optional Components	8-3
SERVICE	8-4
Supplies	8-4
Tools	8-4
Expendable	8-4
Replaceable	8-4
General	8-5
Battery removal	8-5
Installation	8-5
Fuse replacement	8-6
Pitch-trim servo replacement	8-7
Electrical component replacement	8-9
AV Control board replacement	8-10
Wire repair	8-11
Wire replacement	8-11
Snap bushing replacement	8-13
Service Schedule Procedures	8-14
Battery terminal cleaning	8-14
Battery recharge	8-14
Terminal tab cleaning	8-14

● NOTE: FOR A SCHEMATIC OF THE ELECTRICAL SYSTEM REFER TO THE POH OR GO TO THE DOWNLOADS PAGE AT WWW.VANSAIRCRAFT.COM

OVERVIEW

▲ WARNING: THE RV-12 CONTROL BOARD IS NOT SERVICEABLE. SERIOUS RISK OF ELECTRIC SHOCK REMAINS AFTER THE POWER SUPPLY IS REMOVED.

The RV-12 electrical system is a 12 VDC, negative ground system. A 12 VDC sealed dry cell battery mounts on the forward side of the firewall. The generator operates only while the engine is running. The generator supplies power to the regulator, which serves the primary aircraft power and charges the battery. The primary aircraft power is a 30 amp fused circuit. Lights, servos, fans, avionics, fuel pump, and safety switches are all fused secondary circuits and part of the primary circuit.

• **NOTE: This maintenance manual is intended to be used in conjunction with the RV-12 Kit Assembly Instructions (KAI) when completing maintenance or repair processes.**

COMPONENTS

Quantity	Part or Assembly Name	Part Number or Reference
1	Battery	ES PC680
12	Blade Fuse	ATO/ATC ¼ " blade style 1, 2, 3, 5, 7.5, 30 Amp rating. All fuse values of 3 amp and higher are required to have LED "blown fuse" indicators.
1	Stall Warning switch	ES E22-50K
2	Fuselage pin switch	ES E22-50K
1	Pitch-Trim servo	ES-MSTS-T3-7A-2
2	Cooling Fan	SW3DPS
1	12 VDC Supply	AS212
2	Grip Switch	PTT SWITCH & COVER
2	Intercom jacks (Headset)	AV FC-JACK SET
2	Intercom jacks (MIC)	AV FC-JACK SET
1	Master relay	ES 24115
1	Instrument panel control board	AV Control Board 12
16	Terminal Tab (wing-to-fuse)	VA-262
1	OAT Sender	Refer to Dynon Manual
2	EGT sender	Refer to Dynon Manual
2	CHT sender	Refer to Dynon Manual
1	Starter	Refer to Rotax Manual
1	Regulator	EA-F4120 or EA-F4122
1	Ignition A	Refer to Rotax Manual
1	Ignition B	Refer to Rotax Manual
1	Starter relay	Refer to Rotax Manual

OPTIONAL LIGHTING

The lighting components include the wing tip strobe light, extension, landing light rib, landing light, lens backing strip, landing light lens, cooling shroud and red eyeball cockpit light. See **Figure 20**. The wing tip light mounts in the extension which attaches to the wing tip. The landing light is mounted to the landing light rib which is attached inside the wing skin. The eyeball light mounts to the rollover structure. **Refer to the KAI for empennage component removal and installation.**

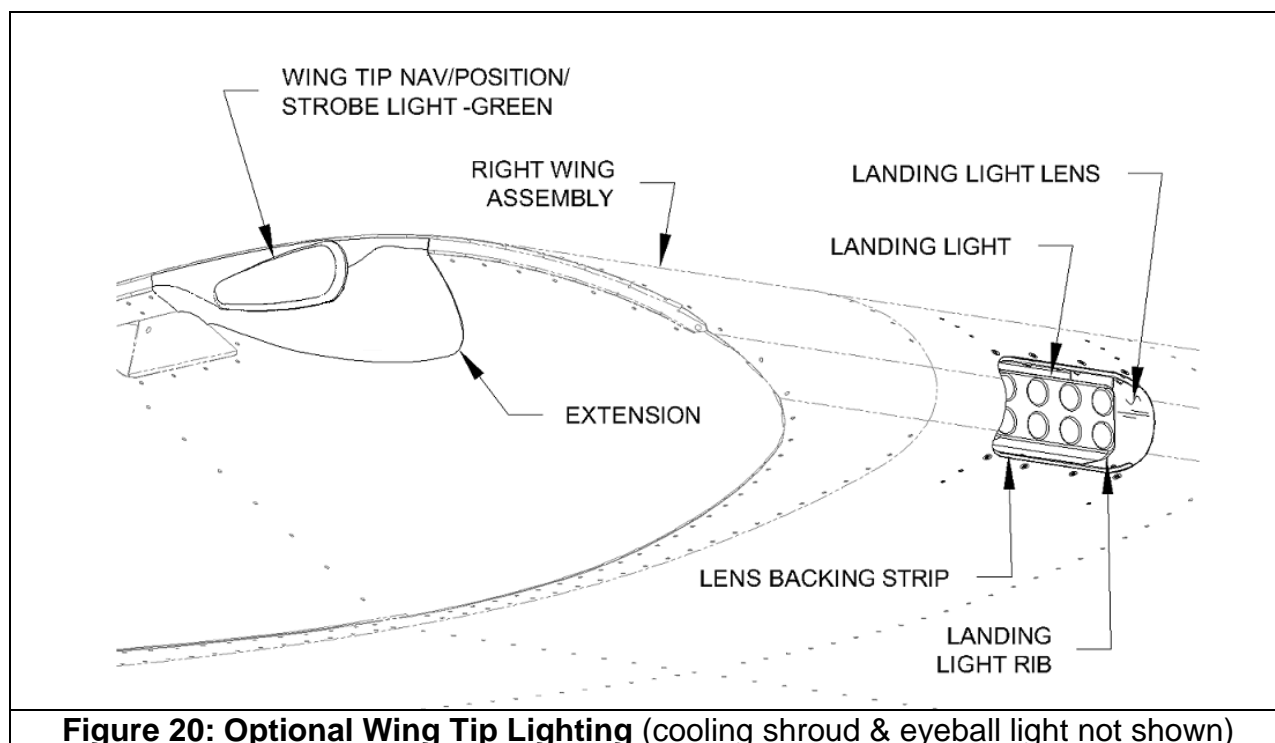


Figure 20: Optional Wing Tip Lighting (cooling shroud & eyeball light not shown)

OPTIONAL COMPONENTS

Quantity	Part or Assembly Name	Part Number or Reference
1	Lighting	See shaded items below & Refer to KAI
1	Wing Tip NAV/Position/ Strobe Light Set	LN-200-1 (green light shown)
2	Extension	W-1222-L and W-1222-R
1	Lens Backing Strip	W-1223E
1	Landing Light	LL-200
1	Landing Light Lens	LL DW 10 Lens Only
	Not Shown	See shaded items below & Refer to KAI
1	Landing Light Rib	W-1223B
1	Rect./Reg. Cooling Shroud	F-00002
1	Red Eyeball Cockpit Light	LC ECL-02

SERVICE

▲ WARNING: ALWAYS HAVE AN APPROPRIATE FIRE EXTINGUISHER READILY AVAILABLE.

▲ WARNING: BEFORE PERFORMING ANY MAINTENANCE OR REPAIRS TURN THE MASTER SWITCH 'OFF' AND DISCONNECT THE NEGATIVE (-) BATTERY CABLE FROM THE BATTERY.

■ CAUTION: REPLACEMENT COMPONENTS, WIRE, TERMINALS, AND FUSES MUST BE OF THE SAME TYPE AND RATING AS THE ORIGINAL PARTS.

There are no serviceable electrical components. Replace malfunctioning or failed components. Electrical components that are omitted from the component list on page 8-2 are not considered line maintenance.

SUPPLIES

TOOLS	EXPENDABLE
<ul style="list-style-type: none"> ◆ Socket: <ul style="list-style-type: none"> ▪ 3/8 ▪ 7/16 ▪ 10 mm ◆ Battery charger ◆ Scouring pad or equivalent ◆ Wire terminal crimping tool ◆ Wire cutter ◆ Multi-meter ◆ Razor knife ◆ Screwdriver <ul style="list-style-type: none"> ▪ #2 Phillips ▪ #8 Phillips ◆ Needle nose pliers ◆ Fire extinguisher ◆ 4mm Allen wrench 	<ul style="list-style-type: none"> ◆ Baking soda/water ◆ Wire terminals: <ul style="list-style-type: none"> ▪ Splice ▪ Spade (male/female) ▪ Ring
	REPLACEABLE
	<ul style="list-style-type: none"> ◆ See component list on page 8-2. ◆ Wire (gauge = original) ◆ Snap bushing (size = original)

GENERAL

BATTERY REMOVAL

▲ WARNING: NEUTRALIZE BATTERY CORROSION WITH WATER/BAKING SODA MIX.

Tools	4 mm allen wrench, 3/8 socket
Expendable	None
Replaceable	Battery
Service Rating	Preventative
Minimum Certification	Owner and SPC, LSA-RM or A&P
Additional References	Odyssey owner manual

1. Remove the top cowl. (12-4)
2. Remove the negative (-) battery cable.
3. Remove the positive (+) battery cable.
4. Remove the battery channel.
5. Lift the battery to remove.

INSTALLATION

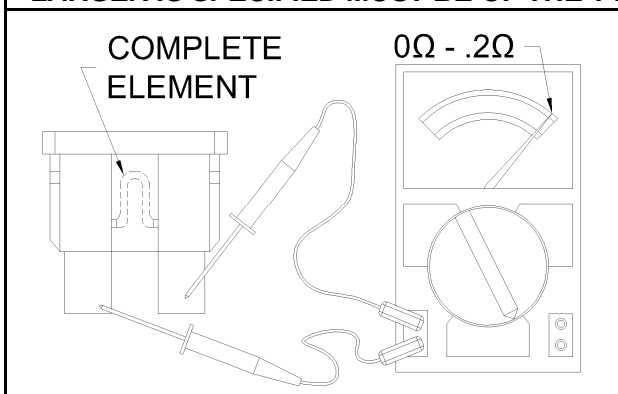
1. Installation procedure is reverse of the removal procedure.

FUSE REPLACEMENT

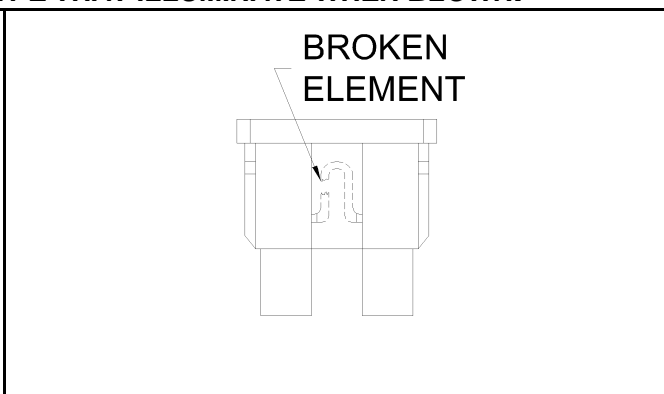
■ **CAUTION: BLOWN FUSES MUST BE REPLACED ONLY WITH FUSES OF THE SAME TYPE AND RATING AS SPECIFIED BY THE MANUFACTURER.**

■ **CAUTION: THE MASTER SWITCH MUST BE IN THE 'OFF' POSITION BEFORE REPLACING ANY FUSE.**

● **NOTE: REPLACEMENT FUSES FOR ANY CIRCUIT IN WHICH A 5 AMP FUSE OR LARGER IS SPECIFIED MUST BE OF THE TYPE THAT ILLUMINATE WHEN BLOWN.**

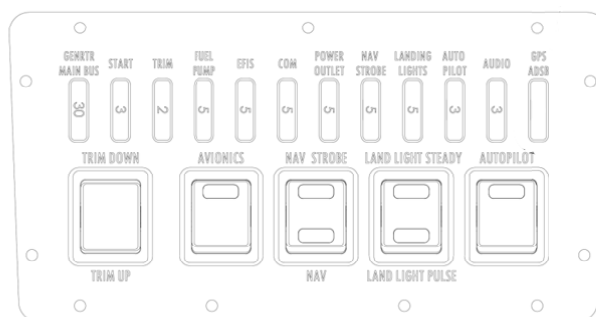


Good Fuse

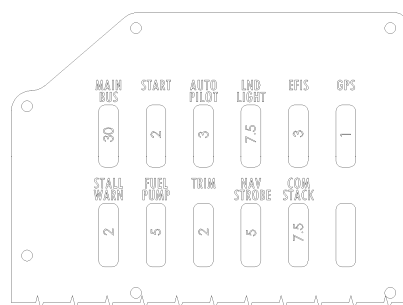


Blown Fuse

1. Remove the suspected blown fuse.
2. Perform visual inspection and/or use multi-meter to test fuse.
3. Insert new fuse with proper rating as shown in **Figure 21**.
4. A recurring blown fuse indicates excessive current draw from the corresponding circuit of the electrical system. See Chapter 18.



SkyView/G3X



D-180

Figure 21: Fuse panel

PITCH-TRIM SERVO REPLACEMENT

Tools	3/8, 7/16 socket 3/16 combo wrench #2 Phillips screwdriver Wire cutter Terminal crimping tool Needle nose pliers
Expendable	Wire terminals
Replaceable	Pitch-Trim servo
Service Rating	Line
Minimum Certification	LSA-RM, or A&P
Additional References	KAI

1. Disconnect the negative (-) battery cable.
2. Remove the upper and lower tailcone fairing. (3-4)
3. Label, then disconnect the pitch-trim servo wire terminal connections. Remove the cushioned clamp and free the tailcone wire from the trim/servo assembly.
4. Make note of the hardware configuration.
5. Disconnect the trim/servo assembly from the AST assembly by removing the bolt, washers (3) and nut as shown in **Figure 22**.
6. Disconnect the trim/servo assembly from the tailcone by removing the cotter pin, bolt, bushings (2), washer and nut. Remove the trim/servo assembly from the aircraft as shown in **Figure 22**.

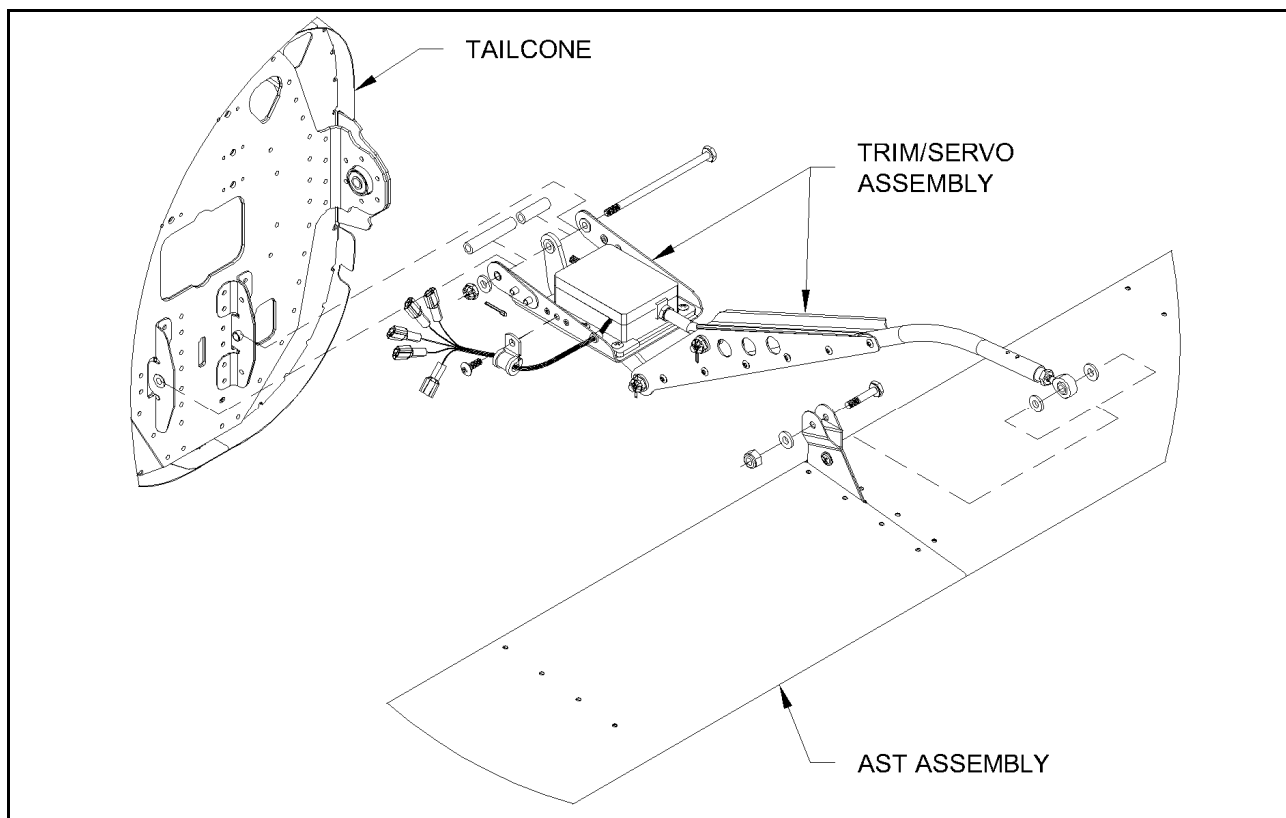


Figure 22: Trim/Servo assembly removal

7. Remove the pitch-trim servo attach screws (6), washers (6), nuts (6), and doublers (2) as shown in **Figure 23**.
8. Unscrew the pitch-trim servo from the pushrod assembly. Remove the jam nut from the pitch-trim servo shaft.
9. Clip the wire terminals off of the old servo and remove the snap bushing. Slide the snap bushing onto the wires of the new servo.

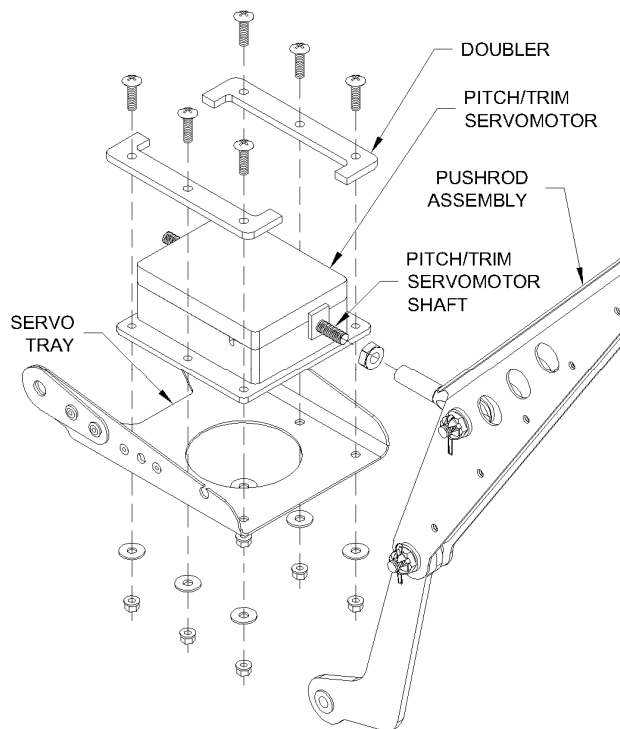


Figure 23: Pitch-trim servo removal

1. Install new terminals on the three colored wires of the servo.

2. Thread the jam nut onto the new pitch-trim servo shaft until it contacts the pitch trim servo shaft housing. Thread the pitch-trim servo shaft onto the clevis rod end on the pushrod assembly until it contacts the jam nut. Back the pitch-trim servo off two full turns. Tighten the jam nut against the pushrod assembly.

INSTALLATION

1. Install the servo on the servo tray by reversing the process done in step 7.
2. Install the trim/servo assembly by reversing the process used in step 6.
3. Connect the three colored pitch trim servo wires with previously installed terminals to the matching colored wires on the pitch trim CONTROL CABLE.
4. Temporarily connect the two white wires on the pitch trim servo to the remaining two wires on the pitch trim control cable.
5. Switch on the master switch and verify that when the pitch trim is activated in the nose down direction, the antiservo tab assembly moves up. If the AST moves in the wrong direction, swap the two white wire positions and recheck.
6. When the AST movement has been verified as correct, install appropriate connectors on each wire for connecting to the pitch trim control cable.

ELECTRICAL COMPONENT REPLACEMENT

(EXCLUDING THE PANEL CIRCUIT BOARD)

▲ WARNING: BEFORE PERFORMING ANY MAINTENANCE OR REPAIRS TURN THE MASTER SWITCH 'OFF' AND DISCONNECT THE NEGATIVE (-) BATTERY CABLE FROM THE BATTERY.

■ CAUTION: REPLACEMENT COMPONENTS, WIRE, TERMINALS, AND FUSES MUST BE OF THE SAME TYPE AND RATING AS THE ORIGINAL PARTS.

Tools	3/8, 7/16 socket #2 Phillips screwdriver Wire cutter Terminal crimping tool Needle nose pliers
Expendable	Wire terminals
Replaceable	See component list. (8-2)
Service Rating	Line
Minimum Certification	LSA-RM, or A&P
Additional References	KAI

1. Disconnect negative (-) ground wire.
2. Remove the applicable access covers to expose the failed component (3-4)
3. Label the wires. Disconnect the wire(s) from the failed component.
4. Make note of the hardware configuration.
5. Disconnect the mechanical connection, if applicable.
6. Remove the hardware that secures the component and remove the component.
7. Install a new component, new gaskets (if applicable), and hardware of the same

- type.
8. Re-attach applicable electrical and mechanical connections.
 9. Reconnect the negative (-) battery cable.

AV CONTROL BOARD REPLACEMENT

Tools	#2 Phillips screwdriver small flat blade screwdriver
Expendable	None
Replaceable	AV Control Board
Service Rating	Line
Minimum Certification	LSA-RM,A&P or Approved Owner
Additional References	KAI

1. Disconnect negative (-) battery cable.
2. Remove the panel cover. (3-4)
3. Discharge the circuit board. With the master switch 'ON', press the stall warning vane until the tone fades off. If wings are removed, ground the stall warning terminal tab at the fuselage side cover as shown in **Figure 24**.
4. Verify all plugs and connectors and their connected locations are properly labeled.
5. Disconnect the control board connections.
6. Remove the control board attachment hardware.
7. Remove the control board.
8. Install the new control board and hardware of the same type.
9. Re-attach all plugs and connectors.
10. Reconnect the negative ground wire to the battery.
11. Test for correct operation of all electrical circuits.

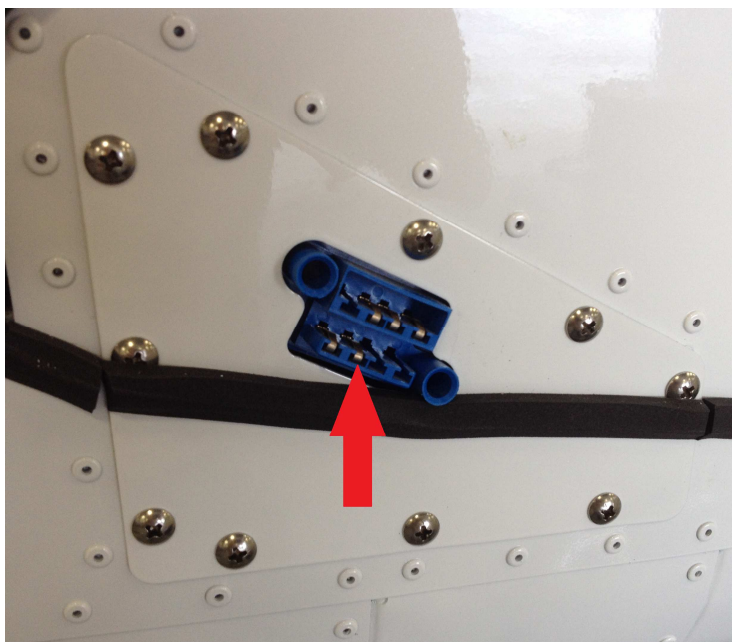


Figure 24: Stall Warning Ground

WIRE REPAIR

Tools	Wire cutter Wire terminal crimper Multi-meter
Expendable	Wire terminals
Replaceable	Wire
Service Rating	Line
Minimum Certification	LSA-RM, or A&P
Additional References	ASTM F39 F2639

■ CAUTION: THE REPLACEMENT WIRE SIZE AND TYPE MUST BE EQUAL TO THE ORIGINAL.

1. Remove the entire damaged section of the wire.
2. Fix the issue that caused damage to the original wire (sharp edge, chaffing, heat, etc).
3. Route the new length of wire along the same path as the original wire.
4. Use aircraft grade wire terminals to connect the new wire in place of the original wire.
5. Test the continuity of the wire to ensure a complete connection.
6. Test the operation of the electrical system.

WIRE REPLACEMENT

Tools	Wire cutter Wire terminal crimper Needle nose pliers Multi-meter
Expendable	Wire terminals
Replaceable	Wire
Service Rating	Line
Minimum Certification	LSA-RM or A&P
Additional References	ASTM F39 F2639

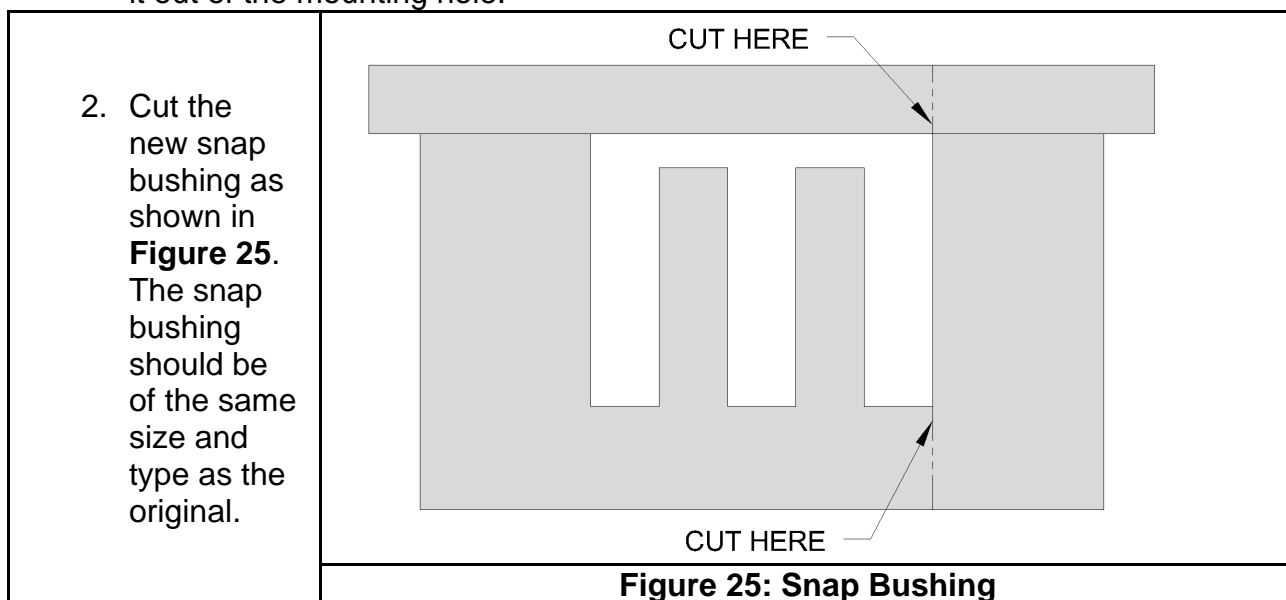
■ CAUTION: THE REPLACEMENT WIRE SIZE AND TYPE MUST BE EQUAL TO THE ORIGINAL.

1. Bypass the existing wire with a new wire of equal length.
2. Install new terminals on the new wire that are the same type as those on the existing wire.
3. Connect the new wire terminals to the terminals that are connected by the existing wire.
4. Check the continuity of the replacement wire.
5. Test the operation of the component that is connected by the replacement wire and test the operation of the entire electrical system.

SNAP BUSHING REPLACEMENT

Tools	Razor knife
Expendable	None
Replaceable	Snap bushing
Service Rating	Line
Minimum Certification	LSA-RM, or A&P
Additional References	KAI

1. Extract the failed snap bushing by compressing the two locking tabs and pushing it out of the mounting hole.



3. Flex open the bushing enough to insert the routed elements.
4. Snap the bushing into the corresponding hole.

SERVICE SCHEDULE PROCEDURES

BATTERY TERMINAL CLEANING

▲ WARNING: NEUTRALIZE BATTERY CORROSION WITH WATER/BAKING SODA MIX.

Tools	Scouring pad
Expendable	Baking soda/water
Replaceable	None
Service Rating	Preventative
Minimum Certification	Owner and SPC, LSA-RM, or A&P
Additional References	Odyssey owners manual

1. Remove the battery from the aircraft. (8-5)
2. Clean and score both battery and wire terminals with a scouring pad or equivalent.
3. Re-install the battery.

BATTERY RECHARGE

Tools	Battery charger
Expendable	None
Replaceable	None
Service Rating	Preventative
Minimum Certification	Owner and SPC, LSA-RM, or A&P
Additional References	Odyssey owner manual Battery charger owner manual

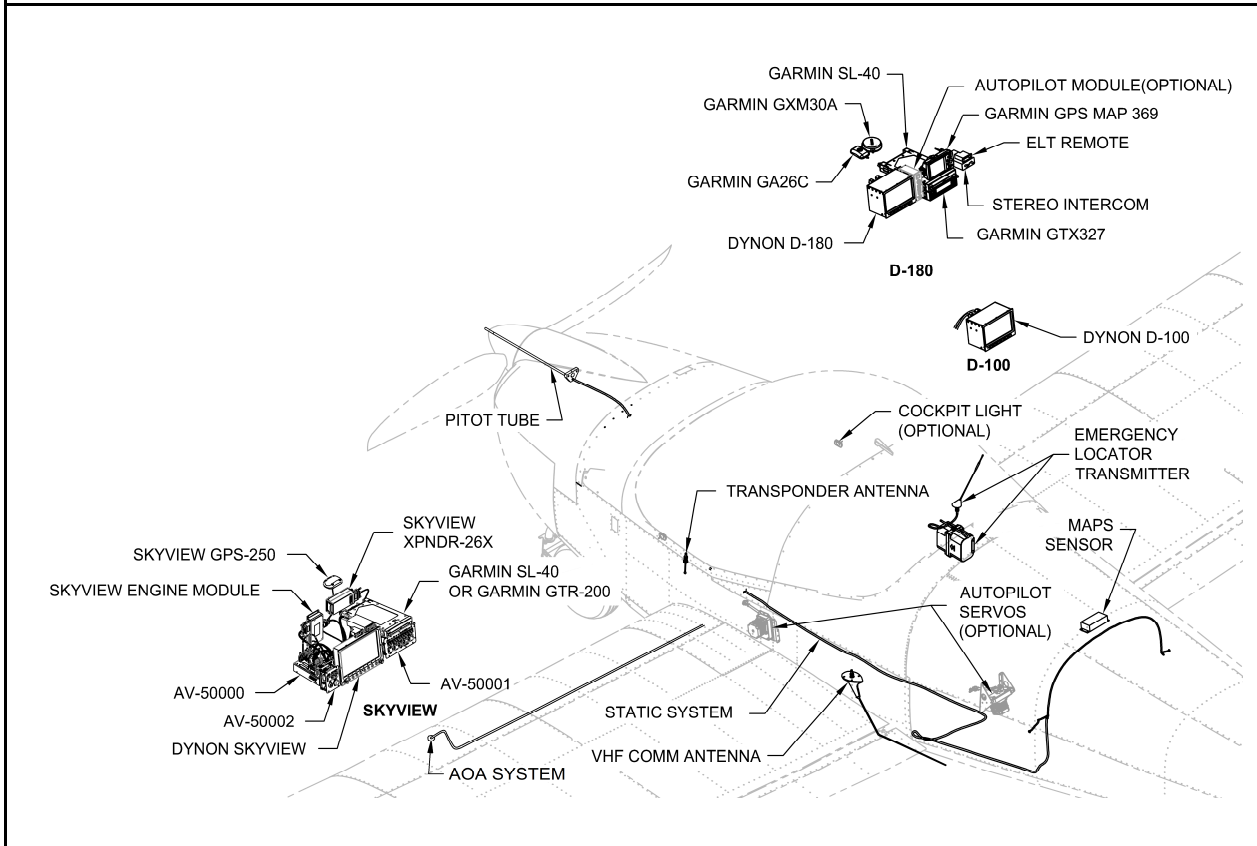
1. Remove the battery from the aircraft. (8-5)
2. Connect the battery charger per the battery charger manufacturer instructions.
3. Charge the battery per the battery manufacturer instructions.

TERMINAL TAB CLEANING

Tools	Scouring pad
Expendable	None
Replaceable	None
Service Rating	Preventative
Minimum Certification	Owner and SPC, LSA-RM, or A&P
Additional References	KAI

1. Remove the wings from the fuselage. (5-13)
2. Remove dirt, carbon and corrosion from all of the terminal tabs on both sides of the fuse and both wings using a scouring pad.

CHAPTER 9 - INSTRUMENTS & AVIONICS



OVERVIEW	9-2
Components	9-2
Optional Components	9-3
PITOT & STATIC.....	9-3
Components	9-3
SERVICE	9-4
Supplies	9-4
Tools.....	9-4
Expendable.....	9-4
Replaceable.....	9-4
General	9-5
Component replacement.....	9-5
Light replacement	9-5
Service Schedule Procedures	9-6
Software updates.....	9-6

OVERVIEW

The Dynon D-180, Dynon SkyView or Garmin G3X EFIS (Electronic Flight Information System) / EMS (Engine Monitoring System) replaces the traditional mechanical flight information and engine monitoring instruments. For removal, installation, inspection, or servicing of the avionics components refer to the manufacturer user manuals.

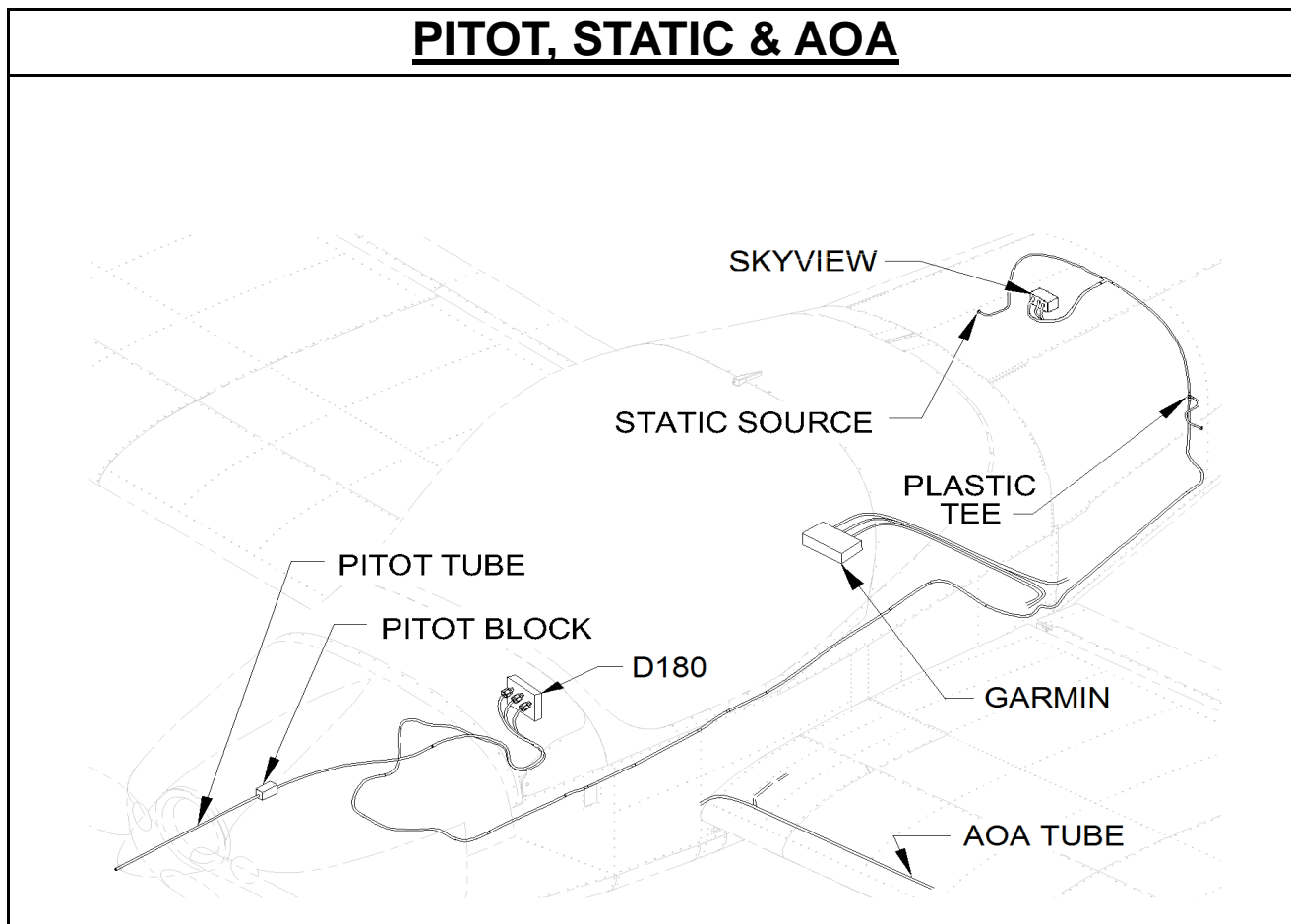
The pitot and static systems provide static and dynamic pressure sources for flight data calculations. The static system ports are located on each side of the tailcone. A flexible plastic tube from the right static port crosses the tailcone to a plastic tee and joins the flexible plastic tube from the left port. From the tee, a flexible plastic tube routes to the floor, then forward within the center tunnel to the air data computer located behind the instrument panel with the D-180 and in the aft fuselage with the Skyview and G3X. The pitot port is an aluminum tube located at the tip of the spinner cone that extends aft to an adapter block mounted to the engine. A flexible plastic tube continues aft from the adapter block to the air data computer.

• **NOTE: This maintenance manual is intended to be used in conjunction with the RV-12 Kit Assembly Instructions (KAI) when completing maintenance or repair processes.**

COMPONENTS

Quantity	Part or Assembly Name	Part Number or Reference
1	Dynon D-180 or Skyview	See Dynon Manual
1	Dynon EDC-D10A	See Dynon Manual
1	Garmin G3X	See Garmin Manual
1	Garmin GPS Map 369	See Garmin Manual
1	Garmin GTX 327 or GTX 23 ES or SV-XPNDR-26X	See Garmin Manual or Dynon manual
1	Garmin SL-40, GTR-200 or GTR-225	See Garmin Manual
1	Garmin GA26C	See Garmin Manual
1	Garmin GXM30A or GA26XM	See Garmin Manual
1	Transponder Antenna	AV CI-101C
1	Emergency Locator Transmitter	AV ME406
1	ELT Remote	453-0023 or E-04.5
1	ELT Antenna	110-773 or E-04.8
1	VHF Comm Antenna	AV AV-17
1	Stereo Intercom	AV FC-403
2	Static Port	RIVET SD-42-BSLF
1	Plastic tee	125 X 125 X 125 TEE
1	Pitot block	FF-1201, UHMW
1	Pitot tube	FF-1202, AT6-058X5/16
1	Pitot line tubing	FF-1216
1	Static line tubing	PT 1/4 OD POLYPROP. TUBE

OPTIONAL COMPONENTS		
2	Autopilot Servo	See Dynon or Garmin Manual
1	Dynon AP-74 Autopilot Interface Module	IF DYNON AP AP74V-12 See Dynon Manual
1	SV-AP-PANEL	See Dynon Manual
1	SV-KNOB-PANEL	See Dynon Manual
1	Garmin GMC 305 Autopilot Controller	See Garmin Manual
1	Landing light	See Aero LED Manual
2	Navigation / Strobe light	See Aero LED Manual
1	Cockpit light	LC ELC-01
1	D-180 or D1000 or D1000T or G3X Dual EFIS / EMS	See Dynon or Garmin Manual
1	AOA indicator system	See Dynon or Garmin Manual



COMPONENTS

Quantity	Part or Assembly Name	Part Number or Reference
2	Static Source	Rivet SD-42-BSLF
1	Plastic Tee	125 X 125 X 125 TEE
1	Pitot Block	FF-1201, UHMW
1	Pitot Tube	FF-1202, AT6-058X5/16

SERVICE

▲ WARNING: ALWAYS HAVE AN APPROPRIATE FIRE EXTINGUISHER READILY AVAILABLE.

▲ WARNING: BEFORE PERFORMING ANY MAINTENANCE OR REPAIRS TURN THE MASTER SWITCH 'OFF' AND DISCONNECT THE NEGATIVE (-) BATTERY CABLE FROM THE BATTERY.

■ CAUTION: REPLACEMENT COMPONENTS, WIRE, TERMINALS, AND FUSES MUST BE OF THE SAME TYPE AND RATING AS THE ORIGINAL PARTS.

Software updates are often available online for the Dynon D-180, Skyview, Garmin GPS, and Garmin G3X. The avionics components are not serviceable by the consumer unless otherwise noted in the manufacturer user manuals. A manufacturer authorized repair facility will perform diagnosis and service to the avionics components.

The Cockpit, Nav/Strobe and Landing lights have no user serviceable parts. Check the supply voltage and circuit connections. Replace the inoperable light if necessary.

SUPPLIES

TOOLS	EXPENDABLE
<ul style="list-style-type: none"> ◆ Wire cutter ◆ Wire terminal crimper ◆ Needle nose pliers ◆ 3/8" combination wrench ◆ 5/64" allen wrench ◆ Razor Knife ◆ Screwdrivers <ul style="list-style-type: none"> ▪ #2 Phillips ▪ Small flat blade ◆ Computer with internet ◆ Unit connection cable 	<ul style="list-style-type: none"> ◆ Wire terminals ◆ Plastic Tie Wraps
	REPLACEABLE
	<ul style="list-style-type: none"> ◆ See component list on page 9-2.

GENERAL

COMPONENT REPLACEMENT

See 9-2 and 9-3.

COMPONENT REMOVAL BY CUSTOMER

Using the KAI as a guide, customers are authorized to remove a screen or any electrical component that is to be sent in for service.

PITOT AND STATIC SYSTEM COMPONENT REPLACEMENT

Tools	Razor Knife
Expendable	Plastic tie wraps
Replaceable	Connector Tubing
Service Rating	Line
Minimum Certification	LSA-RM or A&P
Additional References	KAI

REMOVAL

1. Make note of routing, location and orientation of the component to replace.
2. Remove the failing component.

INSTALLATION

1. Install a new component of equivalent properties and secure with plastic tie wraps.
2. Complete the pitot /static check as outlined in the RV-12 production acceptance test document.

LIGHT REPLACEMENT

▲ WARNING: BEFORE PERFORMING ANY MAINTENANCE OR REPAIRS TURN THE MASTER SWITCH 'OFF' AND DISCONNECT THE NEGATIVE (-) BATTERY CABLE FROM THE BATTERY.

Tools	Wire cutter Wire terminal crimper Needle nose pliers #2 Phillips screwdriver
Expendable	Wire terminals
Replaceable	Light Module
Service Rating	Preventative
Minimum Certification	Owner and SPC, LSA-RM or A&P
Additional References	KAI

REMOVAL

1. Remove the light and fastening hardware;
 - Cockpit light:** screws (3)
 - Landing light:** screws (6), bolts (2)
 - Navigation light:** allen screw (1)
2. Label the wires that will be disconnected.
3. Unplug the wire terminals nearest to the light.

INSTALLATION

1. Install mating wire terminals on the replacement light.
2. Plug the light into the electrical system.
3. Install the new light and hardware.

SERVICE SCHEDULE PROCEDURES

NOTE: THERE IS NO SCHEDULED MAINTENANCE OR SERVICE ON ANY OF THE AVIONICS OR OPTIONAL EQUIPMENT OTHER THAN THE PERIODIC REPLACEMENT OF THE ELT UNIT BATTERY. REFER TO THE ELT OWNERS MANUAL FOR THIS PROCEDURE. PERIODIC CHECKS SHOULD BE MADE AT A MINIMUM OF EACH CONDITION INSPECTION TO DETERMINE IF ANY SOFTWARE UPDATES HAVE BEEN ISSUED FOR THE EFIS/EMS OR GPS.

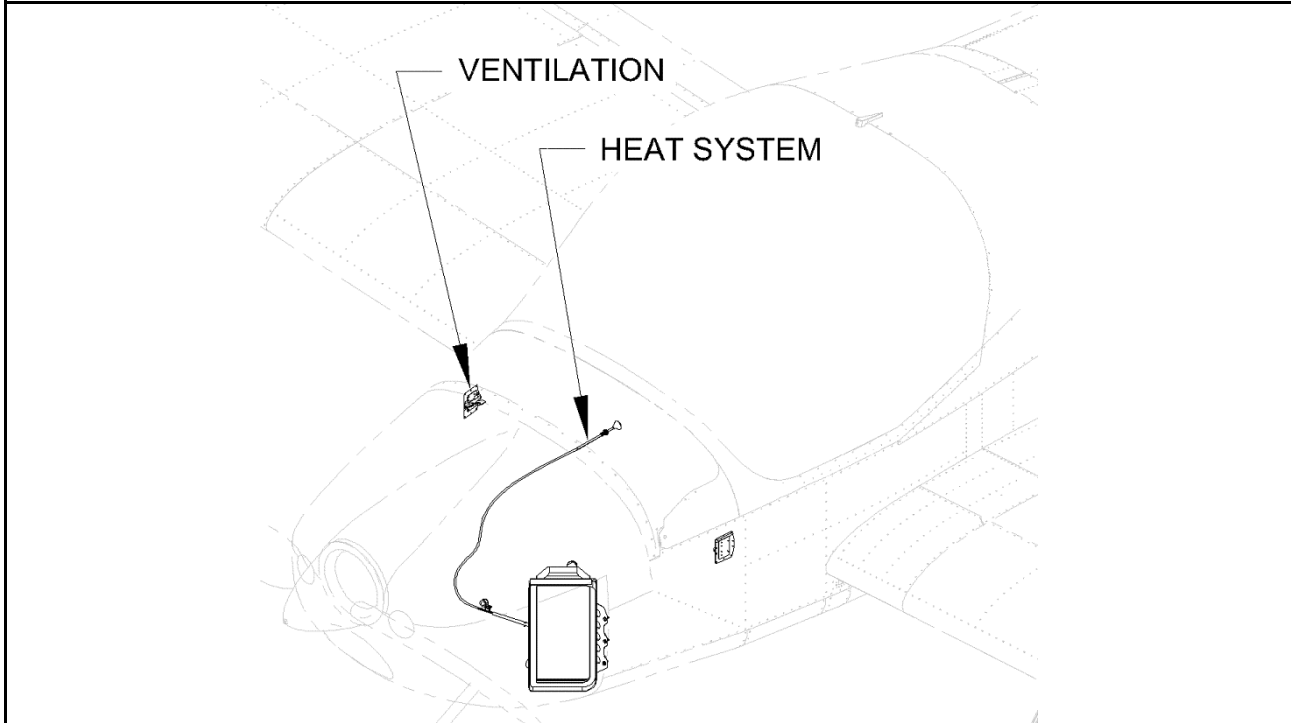
SOFTWARE UPDATES

Tools	Computer with internet access and Unit connection cable
Expendable	None
Replaceable	None
Service Rating	Preventative
Minimum Certification	Owner and SPC, LSA-RM or A&P
Additional References	F39

Refer to the applicable user manual for the instructions and website address.

Firmware updates and Read me files can be found at:
<http://www.vansaircraft.com/public/downloads.htm>

CHAPTER 10 - UTILITY SYSTEMS

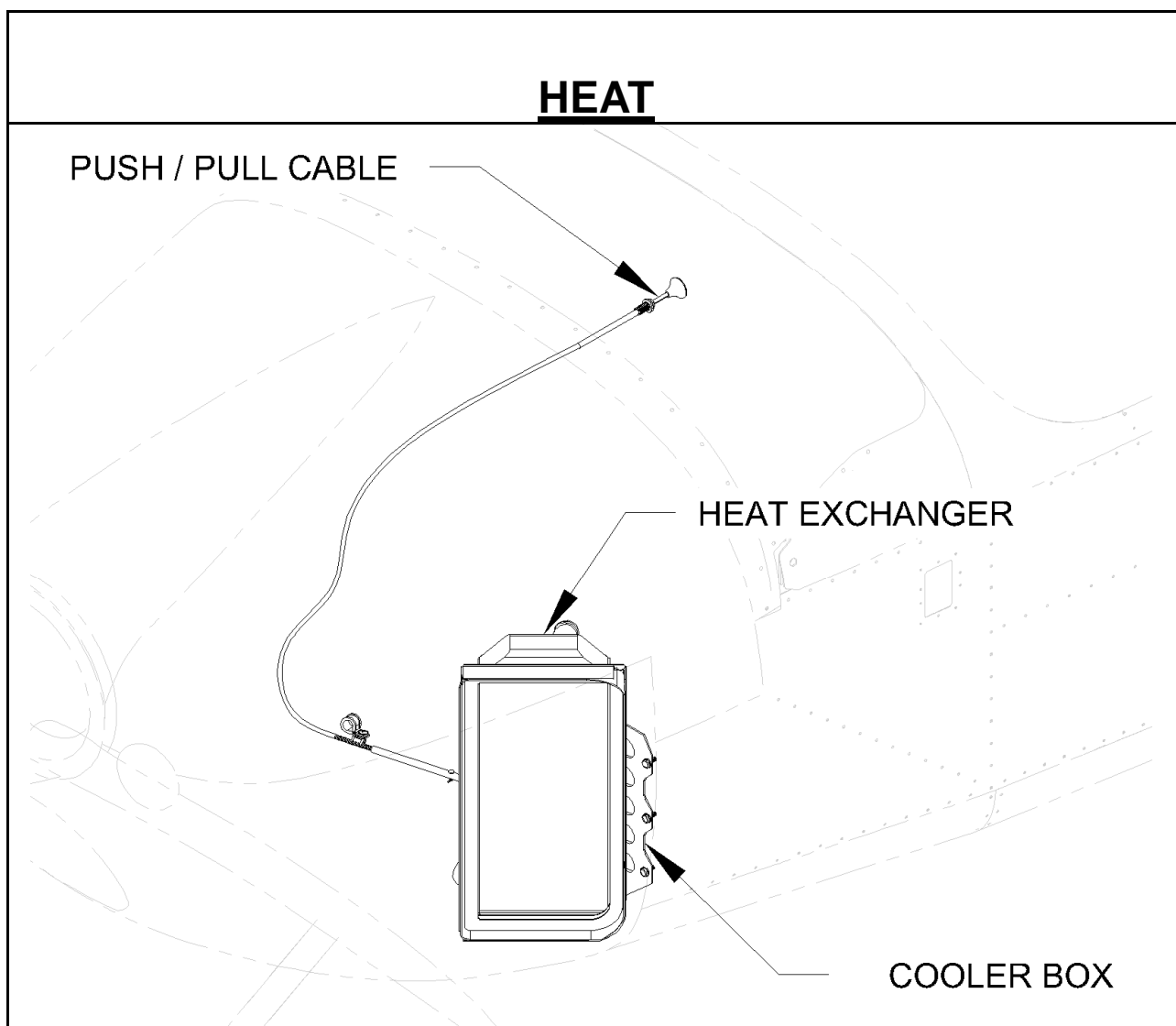


OVERVIEW	10-2
HEAT	10-2
Components	10-3
VENTILATION	10-3
Components	10-4
SERVICE	10-4
Supplies	10-4
Tools	10-4
Replaceable	10-4
Expendable	10-4
General	10-5
Vent door repair	10-5
Service Schedule Procedures	10-5
Push/pull cable lubrication	10-5

OVERVIEW

The aircraft utility systems are the systems that are not critical to flight. The heat system enables the occupants to control the cockpit temperature with a push/pull cable. Hot air diverted from the heat exchangers provides cockpit heat. Cabin ventilation air can be controlled with either of the two vents, one on each side of the fuselage.

• **NOTE:** *This maintenance manual is intended to be used in conjunction with the RV-12 Kit Assembly Instructions (KAI) when completing maintenance or repair processes.*

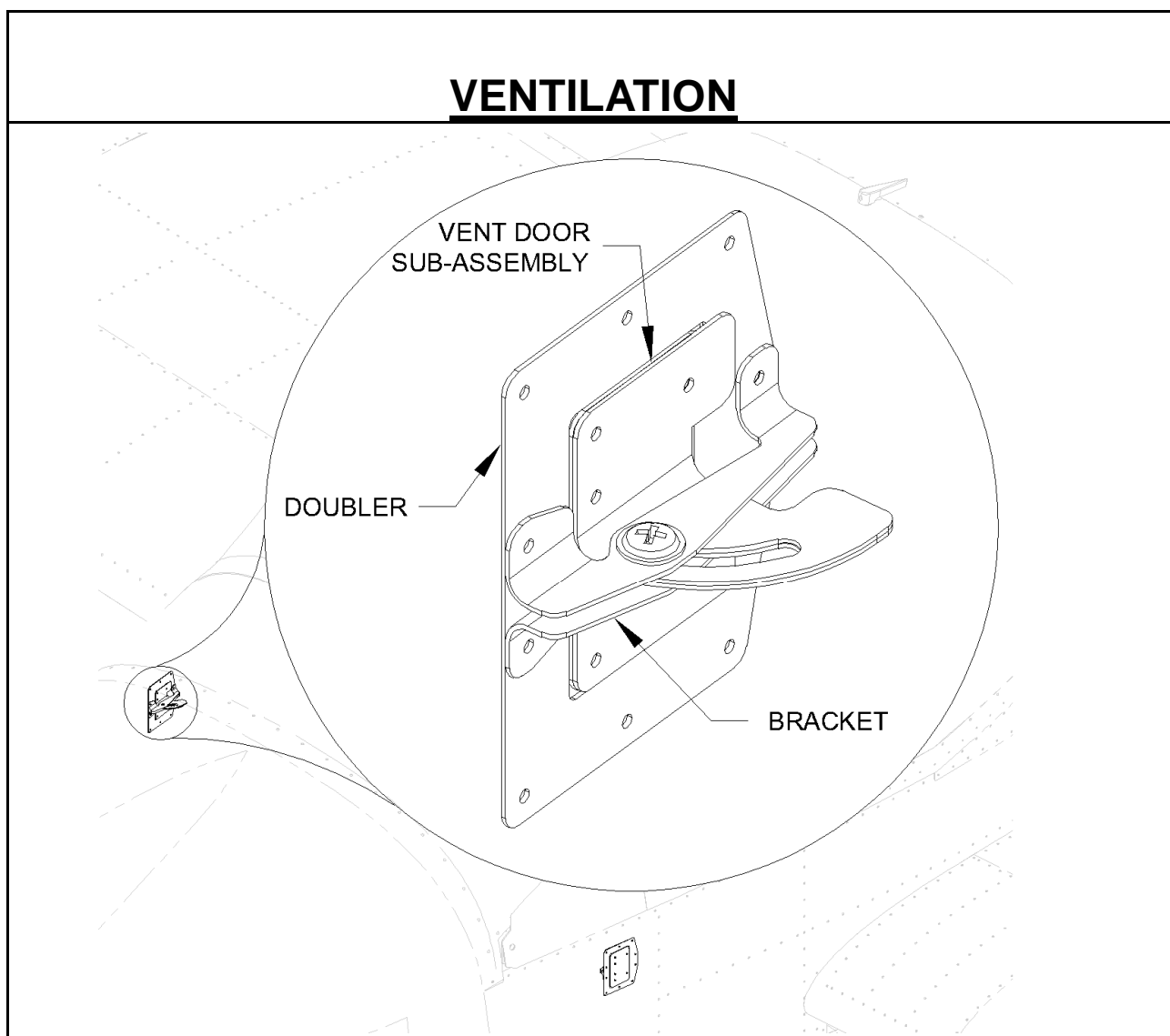


Air that passes through the engine coolant heat exchanger is heated. The heated air continues into the cooler box. A push / pull cable controls a door in the cooler box that diverts the heated air into, or away from the cockpit.

COMPONENTS

Quantity	Part or Assembly Name	Part Number or Reference
1	Cooler box	FF-1204
1	Cooler box door	FF-1205
1	Cooler box bracket	FF-1205BC
1	Cooler box hinge	FF-1206
1	Push / Pull Cable	CT A-740

VENTILATION



A hand-operated vent on each side of the cockpit provides cockpit ventilation. Each vent is a tip-out door installed on each fuselage side skin.

COMPONENTS

Quantity	Part or Assembly Name	Part Number or Reference
2	Vent brackets	F-1086
2	Vent doubler	F-1096
	Vent door sub-assembly	See shaded items below
2	Vent slide	F-1087
2	Vent door doubler	F-1092
2	Vent door	F-1093

SERVICE

The heating system does not require regular maintenance. If the push / pull cable operation is not smooth at the time of the annual condition inspection, lubricate the moving parts. If the heated air temperature is noticeably cooler than previous uses, see troubleshooting.

The pre-flight and annual condition inspections are necessary to ensure all of the components remain in good condition.

No maintenance is required on either of the fresh-air vents. A damaged vent is replaceable provided the fuselage skin is undamaged.

SUPPLIES

TOOLS	REPLACEABLE
<ul style="list-style-type: none"> ◆ Razor Knife ◆ #30 drill bit ◆ Blind rivet tool ◆ Combination wrench: <ul style="list-style-type: none"> ▪ 1/4 ◆ Screwdriver: <ul style="list-style-type: none"> ▪ #2 Phillips 	<ul style="list-style-type: none"> ◆ Connector (= to original) ◆ Tubing (= to original) ◆ Vent door sub-assembly ◆ Vent brackets
EXPENDABLE	
<ul style="list-style-type: none"> ◆ Spray lubricant ◆ Plastic tie wraps ◆ LP4-3 rivets 	

GENERAL

VENT DOOR REPAIR

Tools	#30 drill bit Blind rivet tool 1/4 combo wrench #2 Phillips screwdriver
Expendable	LP4-3 rivets (4) Screw Plastic washers (2) Metal washer Nut
Replaceable	Vent door sub-assembly Vent brackets (2)
Service Rating	Line
Minimum Certification	LSA-RM or A&P
Additional References	KAI

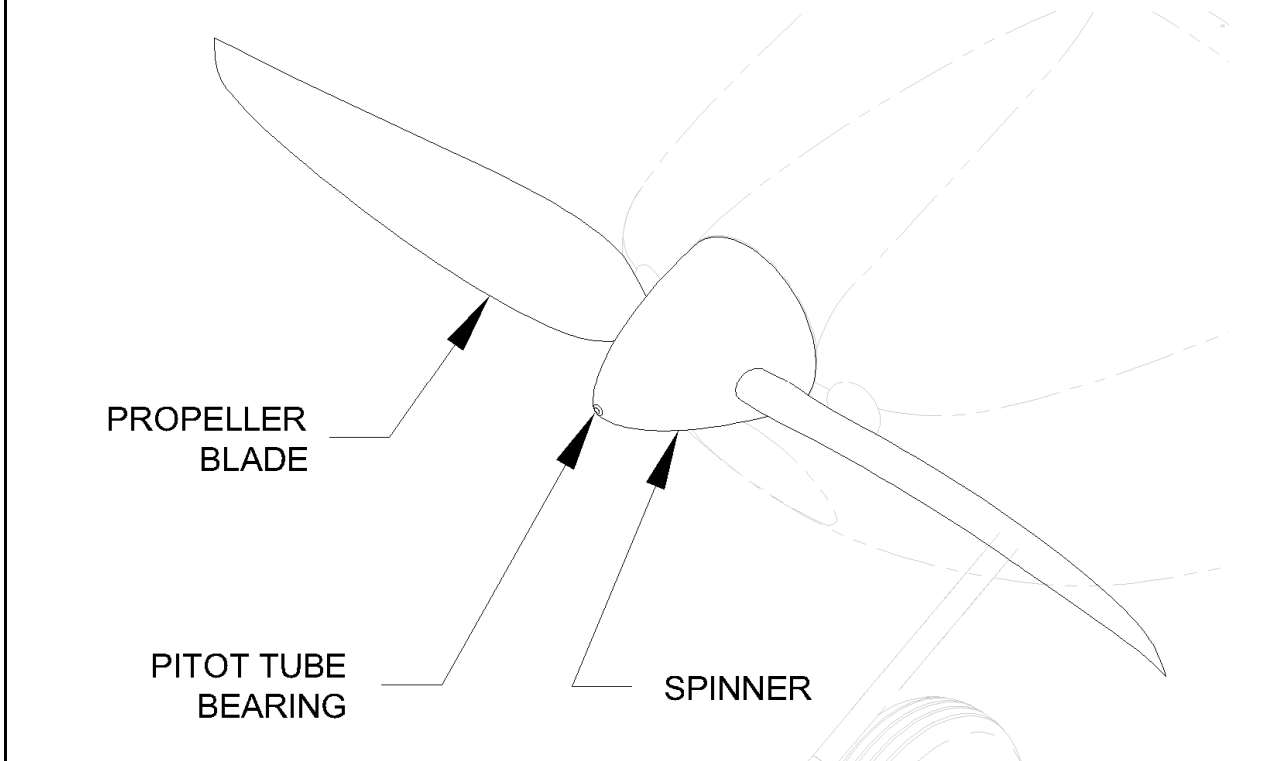
1. Remove the existing vent brackets and vent door sub-assembly by drilling out the rivets (4).
2. Rivet the new vent brackets to the vent doorframe.
3. Install a new vent door sub-assembly to the vent brackets using new hardware; screw, plastic washers (2), metal washer, and nut.

SERVICE SCHEDULE PROCEDURES

PUSH/PULL CABLE LUBRICATION - NONE

THIS PAGE INTENTIONALLY LEFT BLANK

CHAPTER 11 - PROPELLER



OVERVIEW	11-2
Components	11-2
SERVICE	11-2
Supplies	11-2
Tools.....	11-2
Expendable.....	11-2
Replaceable.....	11-2
Spinner and Pitot Tube	11-3
Prop & Hub.....	11-3

OVERVIEW

The RV-12 has a ground adjustable Sensenich propeller. For instructions to adjust the propeller pitch, refer to the user manual provided with the propeller.

The current propeller manuals and/or specifications take precedence over referenced information in this manual. Current revisions to products or specifications made by the propeller manufacturer will not be reflected in this manual.

• **NOTE: This maintenance manual is intended to be used in conjunction with the RV-12 Kit Assembly Instructions (KAI) when completing maintenance or repair processes.**

COMPONENTS

Quantity	Part or Assembly Name	Part Number or Reference
2	Propeller blade	2A0R5R70EN Blade
1	Propeller hub	Hub
1	Spinner cone	S-1201

SERVICE

Brief instructions, referenced from the propeller manual, about caring for the prop and hub are included below. For complete information, refer directly to the propeller manual.

The spinner cone is constructed with a bushing for the pitot tube. It has no scheduled maintenance requirement other than regular inspection and replacement of the bushing if excessive wear is detected.

SUPPLIES

TOOLS	EXPENDABLE
<ul style="list-style-type: none"> ♦ 7/16 diam. wood dowel ♦ Small hammer ♦ Screwdriver: <ul style="list-style-type: none"> ▪ #2 Phillips 	♦ Notebook paper
	REPLACEABLE
	<ul style="list-style-type: none"> ♦ Spinner cone ♦ Pitot tube bushing

SPINNER AND PITOT TUBE

Inspect the Pitot tube and bushing for excessive wear using a clearance gauge. Make the clearance gauge by cutting a $\frac{3}{4}$ inch X 4 inch paper strip from common note book paper (typical thickness is about .003 inch). Make a mark on the strip $\frac{3}{4}$ inch from one end. Lay the paper strip lengthwise on the portion of the pitot tube that protrudes out of the spinner with the marked end positioned nearest to the spinner. Wrap the paper strip tightly around the radius of the pitot tube and attempt to insert it between the pitot tube and the bushing. If the paper strip can be inserted to the marked $\frac{3}{4}$ inch depth further inspection is needed.

Remove the spinner and inspect the portion of the pitot tube that turns within the bushing for wear damage. If any is present the pitot tube and the bushing should be replaced. To replace them see Section 47 of the KAI.

If no wear damage is present on the pitot tube, just the bushing should be replaced.

Remove the worn bushing by driving it out from the aft side of the spinner using a 7/16 in. diameter dowel. Install the new bushing per Section 47 of the KAI.

PROP & HUB

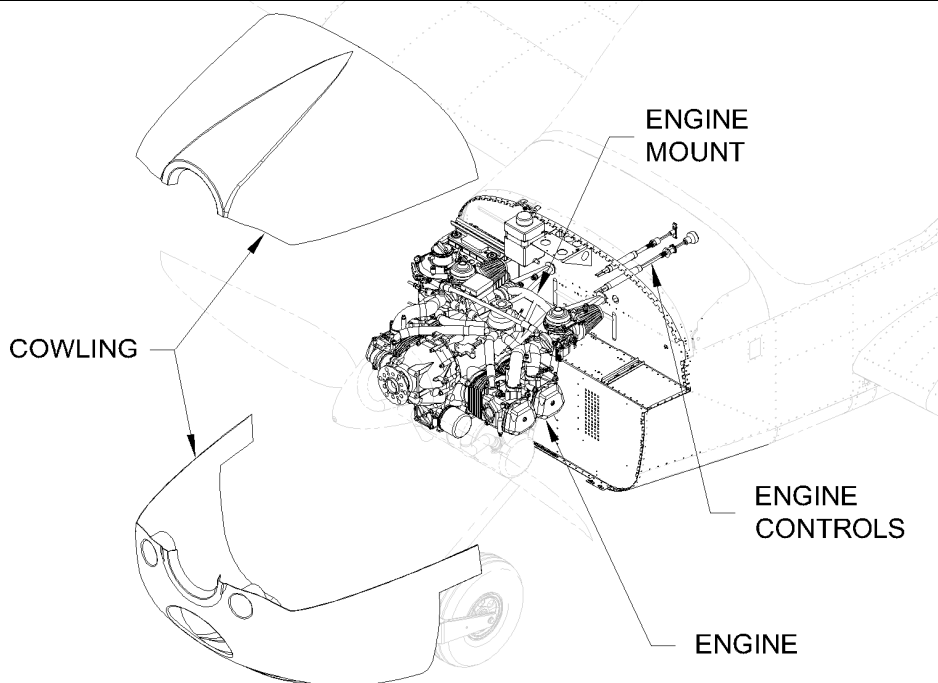
●NOTE: THERE IS NO SPECIFIED SERVICE LIFE FOR THE PROPELLER. HOWEVER IT IS TO BE REMOVED FROM SERVICE WHEN IT NO LONGER MEETS THE CONTINUED AIRWORTHINESS REQUIREMENTS SPECIFIED BY THE MANUFACTURER.

The following will aid in the safe operation, longevity and appearance of the propeller.

- Do not spin your propeller above the Propeller RPM Limits specified by the manufacturer
- Check the hub clamping bolt torque after the first 5 hours and at each condition inspection. Always check in the tightening direction.
- Before each flight carefully Inspect the propeller blades and hub for looseness, any signs of damage, excessive wear or any other condition that would make the propeller unsafe to operate.
- When the propeller is not in use position it horizontally. If it is exposed to weather cover it with a weatherproof cover.
- Do not use the propeller as a tow-bar to move your aircraft.
- Apply a good quality automotive paste wax to the blades at least once a year. Avoid liquid waxes.
- Avoid running-up in areas containing loose stones and gravel.
- Loss of surface finish from the leading edge is considered normal wear and is dependent upon the amount of operation in rain and grit.
- Immediately following an impact of any kind remove the propeller from service until it has been inspected and passed by qualified personnel.

- Whenever there is evidence of rough operation check for proper bolt torque. For new installations it often helps to remove the propeller, rotate it 180° and reinstall.
- If the propeller shows any of the following signs of damage it must either be repaired (if possible) or retired from service:
 - Cracks in the metal hub or bolts
 - Loose metal leading edge
 - A crack across the blade
 - A long or deep crack along the blade length
 - Any portion of composite material missing
 - Obvious damage or wear beyond economical repair

CHAPTER 12 - FIREWALL FORWARD



OVERVIEW	12-2
Components.....	12-2
Engine.....	12-3
Rotax 912ULS	12-3
Spark Plugs.....	12-3
Ignition.....	12-3
SERVICE	12-3
Supplies	12-4
Tools.....	12-4
Expendable.....	12-4
Replaceable.....	12-4
General.....	12-4
Cowling removal.....	12-4
Spark plug replacement.....	12-5
Oil filter replacement.....	12-5
Engine oil level check.....	12-6
Engine coolant level check.....	12-6
Air filter removal.....	12-7
Installation.....	12-7
Carburetor Synchronization.....	12-7
Throttle Cable Hookup.....	12-10
Vacuum Gauge Hookup.....	12-10
Off Idle Setting.....	12-12
Idle Speed Adjustment.....	12-12
Verify Functionality of Throttle Return Spring.....	12-14
Throttle Spring Replacement.....	12-15
Service Schedule Procedures.....	12-16
Cowl hinge pin lubrication.....	12-16
Oil Hose Replacement.....	12-16
Cooling Hose Replacement.....	12-17
Manifold Pressure Hose Replacement.....	12-17
Cylinder, Piston, and Valve Assembly Replacement.....	12-18
Engine Replacement.....	12-19

OVERVIEW

Engine information is taken from Rotax documentation. For complete engine information refer to the Rotax engine documentation. **Note: Rotax is the primary authority for specifying the level of certification required by an individual performing maintenance or repair on a Rotax 912 engine. Refer to the Rotax documentation to determine the qualifications or training required for any maintenance or repair action.**

The top and bottom engine cowling are a formed composite of fiberglass cloth and epoxy-resin. The cowl is attached using screws and segments of piano hinge. Hinge also attaches the top and bottom cowl halves together. Adhesive heat shielding protects the inner surface of the cowl. The throttle and choke are the only engine controls. Air duct and engine cooling shrouds of similar construction provide cooling to the cylinders and heat exchangers.

• **NOTE: This maintenance manual is intended to be used in conjunction with the RV-12 Kit Assembly Instructions (KAI) when completing maintenance or repair processes.**

COMPONENTS

Quantity	Part or Assembly Name	Part Number or Reference
1	Rotax 912ULS	Refer to Rotax documentation & See Figure 26.
1	Engine mount	WD-1220-PC
4	Vibration isolator	EA 22002-15
4	Engine Mount Bushing	Aluminum tube .376 X .525 X 1.9
	Engine controls	See shaded items below
1	Throttle cable	CT DUAL THROTTLE CABLE
1	Choke cable	CT DUAL CHOKE CABLE
	Cowling	See shaded items below
1	Top cowl	Cowl, 12 Top
1	Bottom cowl	Cowl, 12 Bottom
1	Air duct	Cowl, 12 Cooling Duct
1	Upper cowl hinge	F-1201J
1	Upper cowl hinge	F-1201K
2	Mid cowl hinge	F-12116
2	Lwr cowl hinge	F-12117
2	Cowl attach plate	F-12118
1	Cowl shield	EA EXHST/COWL SHIELD

ENGINE

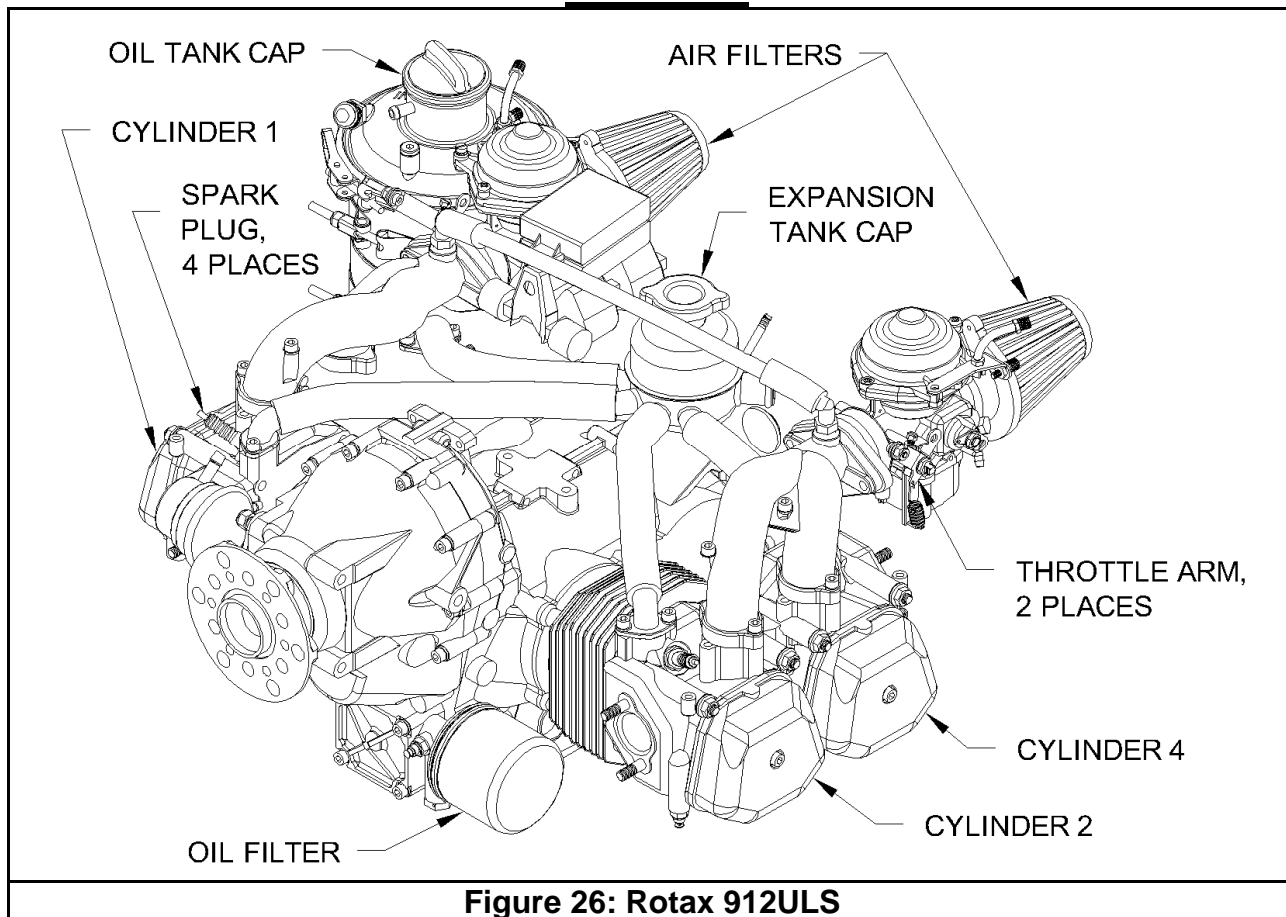


Figure 26: Rotax 912ULS

Current engine product manuals and/or specifications take precedence over any associated information referenced in this manual for convenience. This manual will not reflect current revisions to products or specifications made by the engine manufacturer. Refer to the engine manufacturer's operators manual for specifications.

SPARK PLUGS

Type: NGK DCPR8E

Socket: 16mm

Electrode Gap: See Rotax Documentation

IGNITION

Dual Breakerless Capacitor Discharge

Firing Order: 1 - 4 - 2 - 3

SERVICE

Refer to the engine manual for full engine service details. The cowling does not require regular maintenance. The cowl attach hinge pins may be lubricated with a dry lubricant to ease removal and installation.

SUPPLIES

TOOLS	EXPENDABLE	
<ul style="list-style-type: none"> ◆ Socket: <ul style="list-style-type: none"> ▪ 3/8 ▪ 5/16 ▪ 9/16 ▪ 16 mm (spark plug type) ◆ Combination wrench: <ul style="list-style-type: none"> ▪ 3/8 ▪ 9/16 ◆ Screwdriver: <ul style="list-style-type: none"> ▪ #2 Phillips ◆ Spark plug gap tool (wire type) ◆ Needle nose pliers 	REPLACEABLE	
	<ul style="list-style-type: none"> ◆ Spray lubricant ◆ Engine coolant ◆ Engine oil ◆ Dry lubricant ◆ Oil filter ◆ Safety wire ◆ Cotter pins 	<ul style="list-style-type: none"> ◆ Hinge pins ◆ Spark Plugs ◆ Vibration isolator ◆ Air filter ◆ Push/Pull cable

GENERAL

COWLING REMOVAL

Tools	#2 Phillips screwdriver
Expendable	None
Replaceable	Hinge pins
Service Rating	Preventative
Minimum Certification	Owner and SPC, LSA-RM or A&P
Additional References	KAI

1. Remove the screws (2) in the F-1240B Cover Plate located at the top rear of the cowling to access the cowl attach hinge pins.
2. **Top Cowl:** Remove the top cowl fwd. attach screws (6), side pin anchor screws (2), hinge pins (4) and the top cowl.
3. **Bottom Cowl:** Remove the bottom cowl attach screws (12) located on the bottom of the cowl, the oil cooler attach screws (2) located at the top of the oil cooler, the hinge pins (4) and the bottom cowl. **Note: The oil cooler will remain attached to the airplane, hanging in place by its associated oil hoses.**

INSTALLATION

1. Installation procedure is reverse of the removal procedure. **Note: As the lower cowl is lifted into place maneuver the oil cooler so that its lower notches drop onto the Cowl 12 Guides. The cooler should then self align to allow for installing the attach screws.**

SPARK PLUG REPLACEMENT OR RE-INSTALLATION

Tools	16mm socket Spark plug gap tool
Expendable	Heat conduction compound
Replaceable	Hinge pins Spark Plugs - if serviceable
Service Rating	Preventative
Minimum Certification	LSA-RM with Rotax Service certification or A&P with Rotax Service Certification.
Additional References	Rotax 912 Line Maintenance manual

1. Refer to the Rotax manual.

OIL FILTER REPLACEMENT OR RE-INSTALLATION

Tools	Oil filter wrench
Expendable	Oil Filter
Replaceable	None
Service Rating	Preventative
Minimum Certification	Owner and SPC, LSA-RM or A&P
Additional References	Rotax 912 Line Maintenance manual

ENGINE OIL LEVEL CHECK

▲ WARNING: BEFORE PERFORMING ANY INSPECTION OR SERVICE, ALLOW THE ENGINE COMPONENTS TO COOL.

▲ WARNING: TURN OFF MASTER POWER AND BOTH IGNITION SWITCHES. DISCONNECT THE NEGATIVE (-) GROUND WIRE TO THE BATTERY.

● NOTE: FOR ENGINE OIL CAPACITY SEE ROTAX 912 OPERATORS MANUAL.

Tools	None
Expendable	None
Replaceable	None
Service Rating	Preventative
Minimum Certification	Owner and SPC, LSA-RM or A&P
Additional References	Rotax 912 Operator Manual

1. Remove the oil tank cap.
2. Transfer oil from the crankcase to the oil tank by turning the propeller several times by hand in the direction of normal engine rotation. Transfer is complete when gurgling sounds come from the oil tank.

■ **CAUTION: FOR LONG FLIGHTS REPLENISH OIL TO THE 'MAX.' MARK ON THE DIPSTICK.**

● **NOTE: THE QUANTITY DIFFERENCE BETWEEN 'MAX.' AND 'MIN.' MARKS ON OIL DIPSTICK IS 0.45L (0.5 QUART).**

- Oil level must be between the 'Max' and 'Min' marks on the dipstick.

ENGINE COOLANT LEVEL CHECK

▲ **WARNING: DO NOT REMOVE THE RADIATOR CAP FROM A HOT COOLING SYSTEM. SCALDING COOLANT WILL SPRAY.**

▲ **WARNING: BEFORE PERFORMING ANY INSPECTION OR SERVICE, ALLOW THE ENGINE COMPONENTS TO COOL.**

Tools	None
Expendable	Engine coolant
Replaceable	None
Service Rating	Preventative
Minimum Certification	Owner and SPC, LSA-RM or A&P
Additional References	Rotax 912 Operator Manual

- Place a rag over the expansion tank cap.
- Loosen cap to the first detent then step back for a few seconds.
- Remove the expansion tank cap.
- The expansion tank must be full of coolant.
- Replace the cap.
- The coolant level in the overflow bottle must be between the 'Max' and 'Min' marks.

AIR FILTER REMOVAL

Tools	5/16" Socket
Expendable	None
Replaceable	Air filter
Service Rating	Line
Minimum Certification	LSA-RM or A&P
Additional References	Rotax 912 Line Maintenance manual

- Loosen the air filter clamp.
- Remove the air filter.

INSTALLATION

- Installation procedure is reverse of the removal procedure.

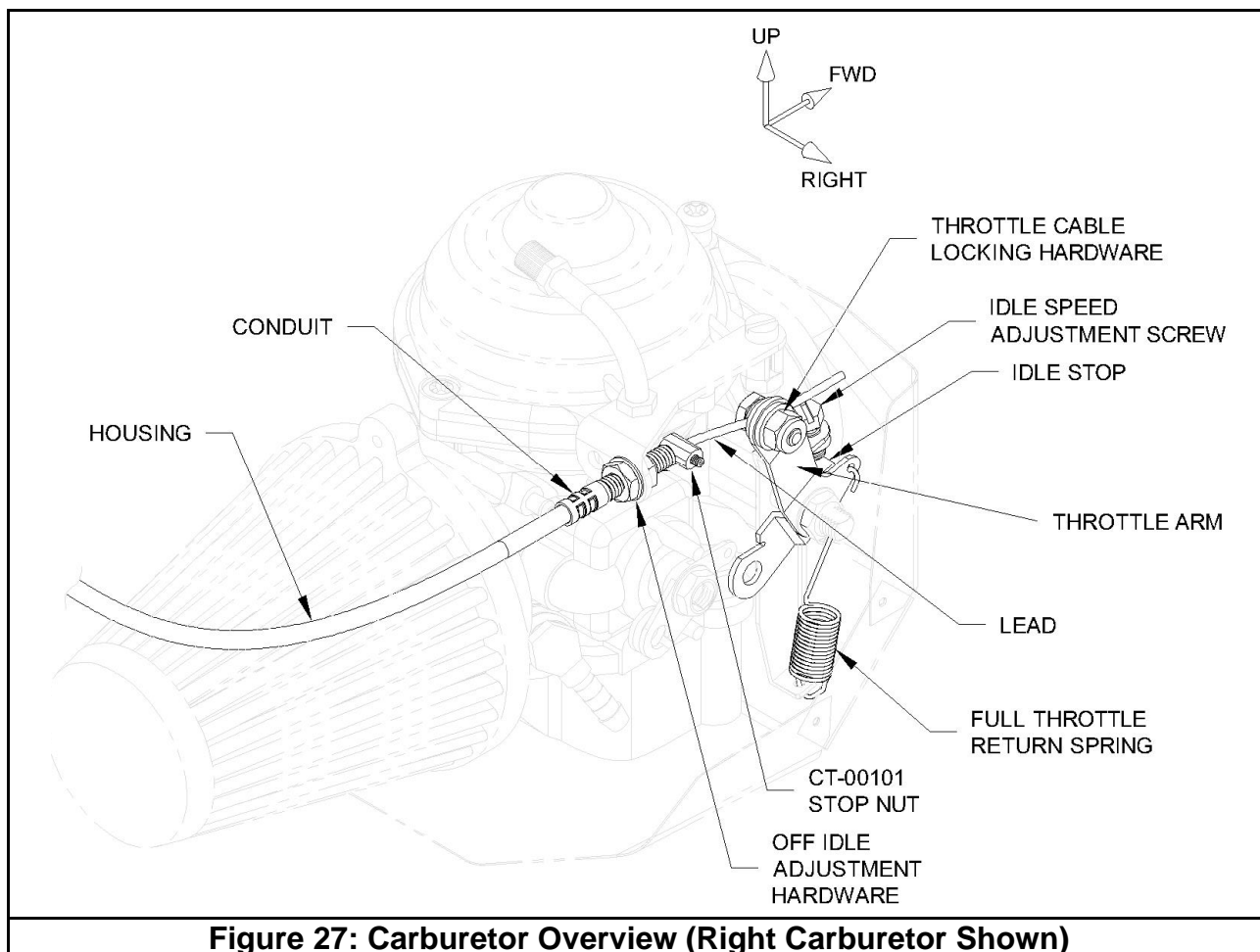
CARBURETOR SYNCHRONIZATION

Tools	1 - Vacuum gauge set 1 - .050 Allen wrench 2 - 3/8 in. combination wrench 2 - 10 mm combination wrench 1 - medium flat blade screwdriver 1 - #2 Phillips screwdriver
Expendable	None
Replaceable	None
Service Rating	Line
Minimum Certification	LSA-RM with Rotax Service certification or A&P with Rotax Service certification
Additional References	Rotax Maintenance Manual

● **NOTE: THIS PROCEDURE IS WRITTEN FOR A SINGLE CARBURETOR. ADJUST BOTH CARBURETORS SIMULTANEOUSLY.**

THE CARBURETOR SYNCHRONIZATION PROCEDURE IN THE ROTAX MAINTENANCE MANUAL SHOULD BE CONSIDERED THE PRIMARY INFORMATION SOURCE FOR ANY AND ALL ENGINE MAINTENANCE. THE FOLLOWING STEPS LIST THE SIMPLEST PROCESS VAN'S AIRCRAFT HAS FOUND TO ACHIEVE THE SMOOTHEST RUNNING ENGINE POSSIBLE.

MECHANICAL SYNCHRONIZATION

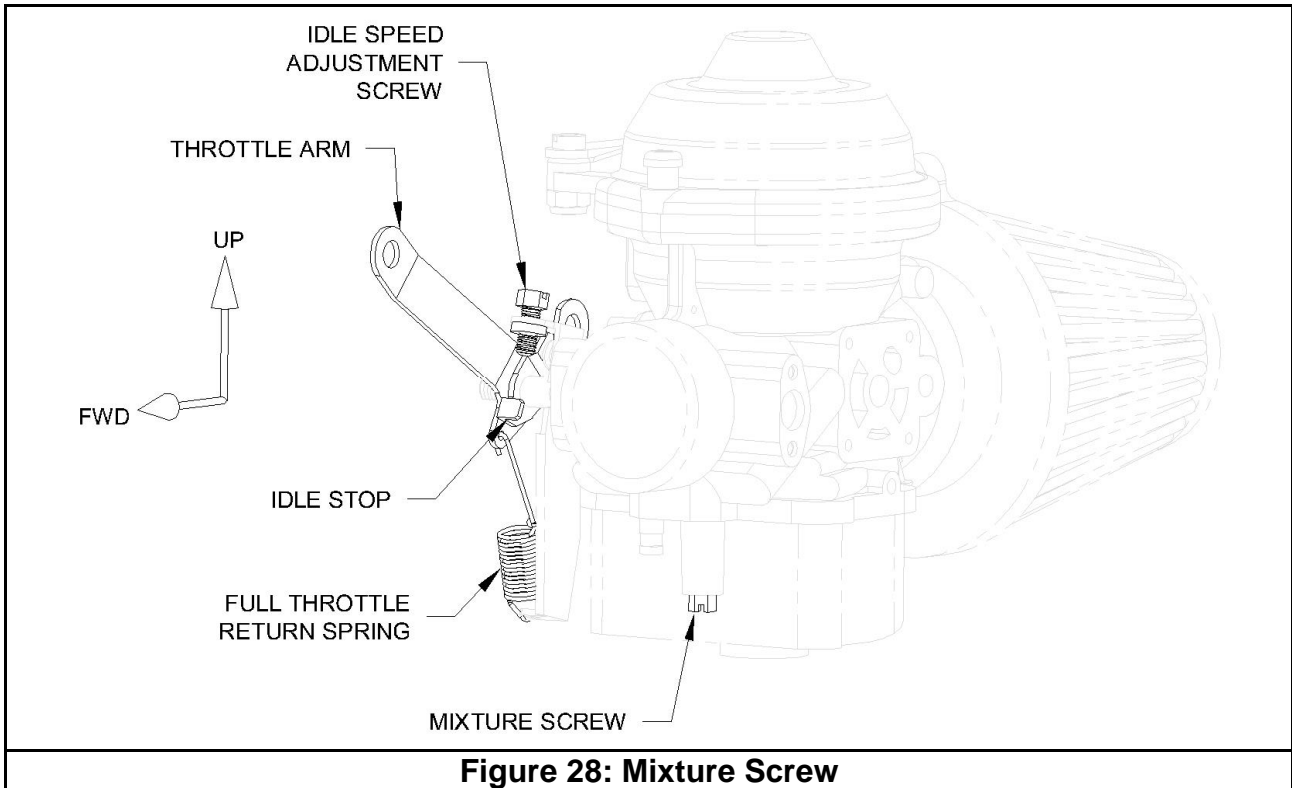


● **NOTE: FOR STEP 1 THROUGH STEP 8 REFER TO FIGURES 27 AND 28.**

1. Remove the throttle cable locking hardware from the throttle arm.
2. Release the full throttle return spring from its attachment on the throttle arm.
3. Return the throttle arm to its idle position limit of travel by hand, there should be no resistance during this procedure.
4. Turn the idle speed adjustment screw counterclockwise until it is no longer contacting the idle stop.
5. Hold the throttle arm lightly against its idle position limit of travel. Insert a .1mm (.004in) feeler gauge between the idle speed adjustment screw and the idle stop. Gently turn the idle speed adjustment screw clockwise until contact is made with the .1mm feeler gauge.
6. From this point turn the idle speed adjustment screw clockwise 1.5 turns.
7. Gently turn the mixture screw completely closed (clockwise) and then reopen by

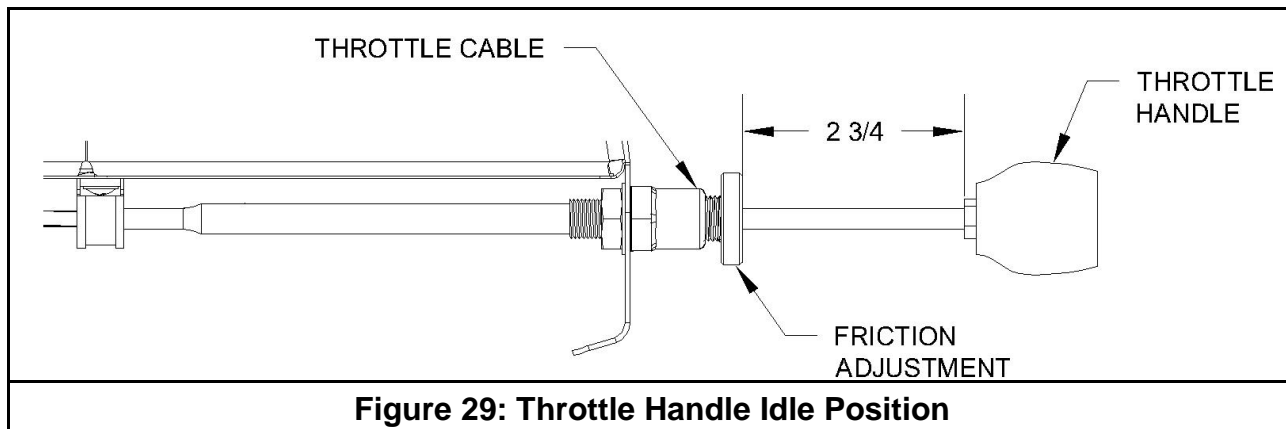
1.5 turns counter-clockwise. Note this step cannot be done without removing the carburetor from the manifold. With a new engine initially assume it is properly set at the factory.

8. Hook-up the full throttle return spring, previously disconnected, back to its original position on the throttle arm.



HOOKING THE THROTTLE CABLE LEAD TO THE THROTTLE ARM

9. Pull the throttle handle away from the instrument panel the distance prescribed in **Figure 29**, then tighten the friction adjustment. This is the idle position.

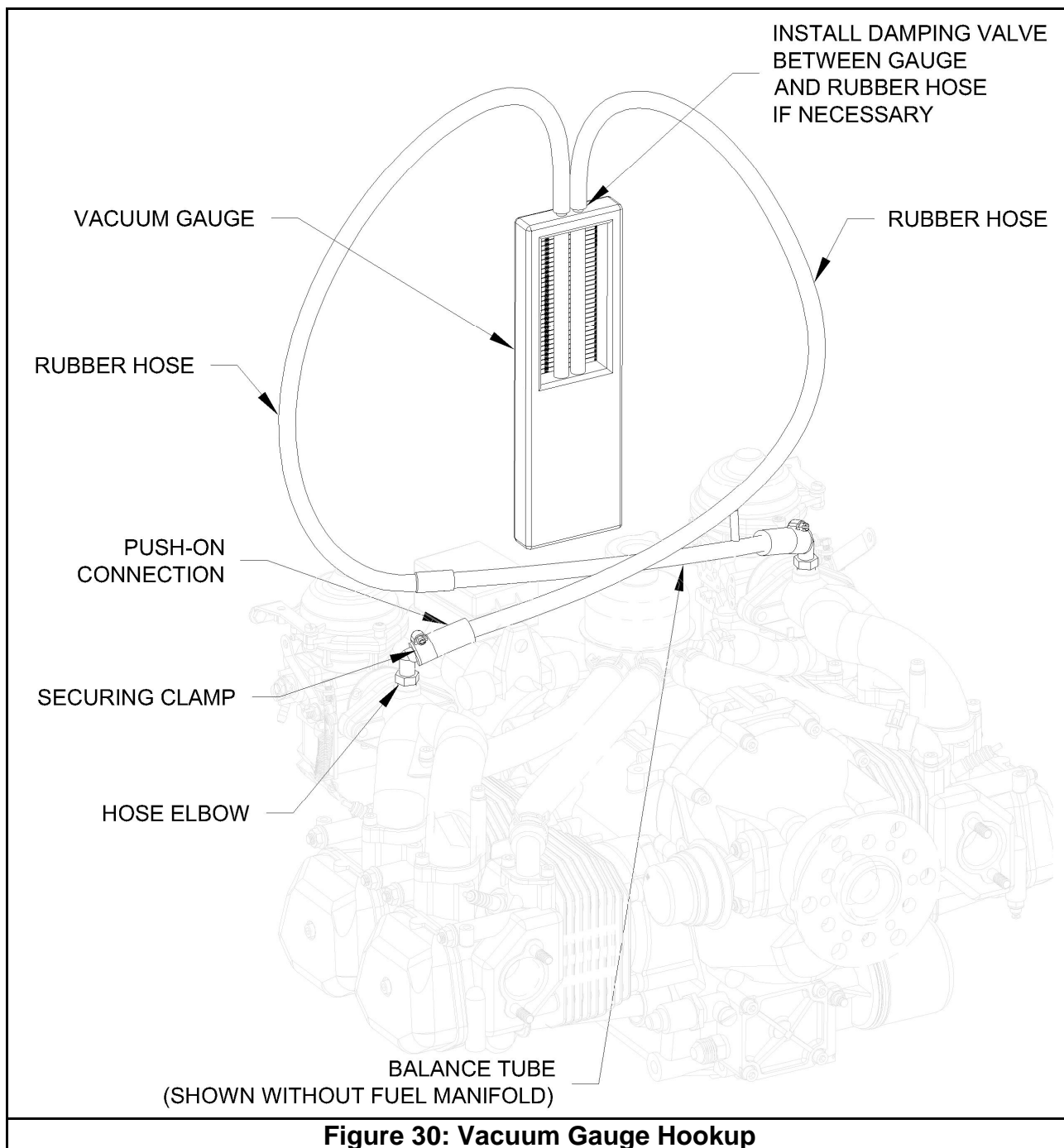


10. Actuate the throttle arm so that the idle stop is lightly contacting the idle speed adjustment screw. While holding tension on the throttle cable lead, tighten the throttle cable locking hardware to 8-10 in-pounds. See Figure 27. You must insure that the idle speed adjustment screw is resting on the idle stop and that there is no clearance between the two when the throttle handle is in the idle position.
11. Loosen the friction adjustment. See Figure 29.

VACUUM GAUGE HOOKUP

● ***NOTE: THERE ARE THREE WAYS TO CONNECT A VACUUM GAUGE AS DESCRIBED IN THE ROTAX MAINTENANCE MANUAL. THE FOLLOWING STEP ASSUMES THE USE OF OPTION 3.***

12. Unhook the balance tube at the right side end by removing the securing clamp from the push-on connection. Using the push-on connection and the hose elbows on the intake manifolds, install rubber hoses leading to a dual vacuum gauge. See Figure 30.



13. Secure the aircraft to the ground using chocks, ropes etc.

▲ WARNING: SECURE AND OBSERVE THE PROPELLER ZONE DURING ENGINE OPERATION!

14. Start the engine and warm it up until normal operating temperatures are achieved.

OFF IDLE SETTING

15. After warming the oil temp to the minimum required for takeoff power application, run the engine to full throttle and verify the engine is developing proper power with an indication of at least 4700 RPM.
16. Verify that both vacuum gauge readings are the same when the throttle is slowly moved between near idle and full power. Use of damping valves (see Figure 30) may be required to smooth out the vacuum gauge readings. Install valves if required and slowly close them until the vacuum gauge readings stop fluctuating rapidly.

If the vacuum gauge readings are not the same, shut down the engine and verify that the choke controls on both carburetors are in the full off position. Also verify that both throttle cable leads (see Figure 27) are resulting in full travel of the throttle arms to the full throttle position on both carburetors. If both are satisfactory move to step 17 for making adjustments.

17. Determine which carburetor has the higher vacuum reading. Loosen the aft nut on the off idle adjustment hardware of the carburetor with the higher vacuum (see Figure 27) and then tighten the fwd nut. This will adjust the throttle (for this carburetor) open an additional amount.
18. Restart the engine and run the engine through the middle of the throttle range. Repeat the adjustment done in step 17 until the vacuum gauge readings for both carburetors are closely matched. If you go too far and the carburetor that you have been adjusting ends up having a vacuum gauge reading lower than the other reverse the adjustment and bring it back to where the vacuum gauge readings match. Once the off idle vacuum gauge readings are balanced confirm that the nuts on the throttle cable locking hardware are tight on both carburetors.

IDLE SPEED ADJUSTMENT

▲ WARNING: DO NOT ADJUST THE IDLE SPEED SCREWS MORE THAN 1/2 TURN EITHER WAY TO ACHIEVE THE PROPER IDLE SPEED! IF A SETTING OF MORE THAN 1/2 TURN IS REQUIRED, REPEAT STEPS 1-8.

IF NO SATISFACTORY RESULT CAN BE ACHIEVED INSPECT THE IDLE JET FOR TRANSLUCENT, JELLY-LIKE CONTAMINATION AND FREE PASSAGE. CLEAN AS REQUIRED.

● **NOTE: WHEN CHECKING THE IDLE SPEED DURING THE ADJUSTMENT PROCEDURE ONLY PULL LIGHTLY ON THE THROTTLE CONTROL UNTIL YOU JUST FEEL THE IDLE STOPS ON THE CARBURETORS. A HEAVY PULL ON THE THROTTLE CONTROL WILL FLEX THE THROTTLE ARMS AND GIVE AN INACCURATE IDLE SPEED.**

● **NOTE: IF THE THROTTLE HANDLE IS HELD FULLY AT IDLE FOR AN EXTENDED PERIOD THE IDLE MAY CREEP DOWN TO APPROXIMATELY 1550 RPM. THIS IS PERMISSIBLE WHEN SETTING UP THE CARBURETORS BUT DURING NORMAL GROUND OPERATIONS THE IDLE SPEED SHOULD BE KEPT AT OR ABOVE 1650 RPM, OR WHATEVER IDLE SPEED IS REQUIRED TO ALLOW THE ENGINE TO RUN SMOOTHLY. OPERATING AT IDLE SPEEDS WHERE THE ENGINE IS MAKING A KNOCKING/RATTLE TYPE NOISE WILL CAUSE GEARBOX DAMAGE.**

● **NOTE: OFTEN TIMES WARMING THE ENGINE BY RUNNING IT ON THE GROUND DOES NOT QUITE BRING IT UP TO NORMAL OPERATING TEMPERATURES. THIS WILL HAVE A SLIGHT EFFECT ON WHAT THE ACTUAL IDLE RPM WILL BE ONCE THE AIRPLANE HAS BEEN FLOWN FOR A FEW MINUTES (FULLY WARMED UP). THE DIFFERENCE TENDS TO BE A 50 – 75 RPM INCREASE. FOR THIS REASON, UNLESS YOU ARE DOING THE CARBURETOR SYNCHRONIZATION PROCEDURE IMMEDIATELY AFTER FLYING THE AIRPLANE, ADJUSTING FOR AN IDLE SPEED NEAR THE BOTTOM OF THE RECOMMENDED RANGE WILL NET YOU A PROPER IDLE OF ABOUT 1650 RPM AFTER THE ENGINE IS FULLY WARMED.**

● **NOTE: VERIFY THE IDLE SPEED AND ADJUST AS NECESSARY TO ACHIEVE 1600-1650 RPM AND SMOOTH ENGINE OPERATION (REMEMBER TO ONLY PULL LIGHTLY AGAINST THE CARBURETORS IDLE STOPS).**

19. A final idle speed adjustment may be required by resetting the idle speed adjustment screws, accordingly. Turning the idle speed adjustment screw clockwise will increase the engine speed / counter clockwise will decrease it. Equal adjustments must be made to each carburetor. Any major adjustments require verification of all parameters in this procedure. Before moving on to the next step, verify that the vacuum gauge readings for the two carburetors are balanced at idle and at off idle throttle settings.
20. Use light pressure on the throttle control to hold it at the idle position, then tighten

the friction lock to hold the throttle control in place. Slide the CT-00101 Stop Nut back against the forward edge of the conduit in the orientation shown in Figure 27, then tighten the CT-00101 set screw.

21. Restart the engine and confirm that when the throttle is pulled hard to the idle stop the idle speed is correct and the vacuum gauge readings for the two carburetors are closely balanced. If they are not, loosen the CT-00101 Stop Nuts on both carburetors and then repeat steps 19 and 20 until they are.
22. Install the balance tube in the reverse sequence of removal. Any minor differences in balance at idle will be compensated for by the balance tube at low engine RPM.

VERIFY FUNCTIONALITY OF THROTTLE RETURN SPRINGS

1. This section must be done with the aircraft outside.
2. Chock main wheels, tie-down tail.
3. BRAKES: Apply FULL
4. Master switch "ON", avionics switch "ON" then power-down transponder, com radio, and GPS
5. Check EFIS for fuel pressure indication
6. Start engine, check for oil pressure functioning and showing pressure
7. Warm the engine to 122^o F
8. THROTTLE- Completely loosen throttle friction knob and observe throttle advance rate.

If the throttle advances rapidly to a partial position, then slowly advances the throttle to full, the springs are functioning correctly. This may take up to 15 seconds.

If the throttle is not pulled to full, the return springs and/or throttle cable need to be replaced before further flight. Consult the RV-12 KAI Section 50.

THROTTLE SPRING REPLACEMENT

Tools	Small Screw Driver
Expendable	None
Replaceable	None
Service Rating	Preventative
Minimum Certification	Owner and SPC, LSA-RM or A&P
Additional References	KAI and ROTAX Line Maintenance Manual

1. Release the friction on the cockpit throttle control and move it to the full open position.
2. Slip a small diameter screwdriver through the bottom end of the spring. Disengage the spring from the cable support and discard the spring.
3. Replace return springs on each carburetor with Van's PN: SPRING-00002.

SERVICE SCHEDULE PROCEDURES

COWL HINGE PIN LUBRICATION

Tools	#2 Phillips screwdriver
Expendable	Dry lubricant
Replaceable	None
Service Rating	Preventative
Minimum Certification	Owner and SPC, LSA-RM or A&P
Additional References	KAI

1. With the cowl hinge pins removed wipe each hinge pin clean.
2. Immediately prior to re-installation apply lubricant along the length of each hinge pin.

OIL HOSE REPLACEMENT

**▲ WARNING: BEFORE PERFORMING ANY INSPECTION OR SERVICE
ALLOW THE ENGINE COMPONENTS TO COOL.**

Tools	1/4, 3/8, 7/8 combo end wrenches, Phillips screwdriver , wire cutters
Expendable	Plastic tie-wrap 8in
Replaceable	Oil Supply Hose, Oil Cooler Hose, Oil Return Hose, Oil Tank Vent Tube, Oil Vent Interconnect
Service Rating	Preventative
Minimum Certification	Owner and SPC, LSA-RM or A&P
Additional References	KAI

REMOVAL

1. Remove Cowl (12-4).
2. Drain oil system per Rotax Line Maint. Manual including draining of the oil cooler.
3. Cut tie-wraps and detach cushioned clamps from oil hoses.
4. Disconnect and remove oil hoses from the oil tank cover assembly, engine and oil cooler.
5. Remove Oil Tank Vent Tube and Oil Vent Interconnect.

INSTALLATION

1. Installation of new hoses and tubes is reverse of removal procedure.
2. Perform oil purge procedure detailed in Rotax Service Instruction SI-912-018.

COOLING HOSE REPLACEMENT

**▲ WARNING: BEFORE PERFORMING ANY INSPECTION OR SERVICE
ALLOW THE ENGINE COMPONENTS TO COOL.**

Tools	3/8 open end wrench, screwdriver, wire cutters
Expendable	Plastic tie-wrap 8in
Replaceable	FF-1208A, FF-1208B, FF-1220
Service Rating	Preventative
Minimum Certification	Owner and SPC, LSA-RM or A&P
Additional References	KAI

REMOVAL

1. Drain cooling system per Rotax Line Maint. Manual.
2. Disconnect cushioned clamps and cut tie wraps from coolant hoses.
3. Loosen hose clamps and slide them away from the component.
4. Disconnect hoses from reservoir, engine, and radiator.
5. Cut new hoses to same length as old ones.
6. Remove springs from old hoses and install in new hoses.

INSTALLATION

1. Installation procedure is reverse of removal procedure.
2. Refer to Rotax Line Maint. Manual to refill coolant.

MANIFOLD PRESSURE HOSE REPLACEMENT

Tools	Wire cutters, straight slot screwdriver(for prying hose)
Expendable	Tie wrap
Replaceable	Manifold pressure hose
Service Rating	Preventative
Minimum Certification	LSA-RM with Rotax Service certification or A&P with Rotax Service certification
Additional References	KAI

REMOVAL

1. Cut the tie wrap attaching the manifold pressure hose to the manifold pressure sensor wires.
2. Remove the hose from the manifold pressure sensor and the from the compensating tube assembly.

INSTALLATION

1. Cut the new hose to the length specified in the KAI.
2. Installation is reverse of removal.

CYLINDER, PISTON AND VALVE ASSEMBLY REMOVAL

Tools	5 mm Allen wrench, 12,13 mm socket, wire cutters, pliers, #2 Phillips & straight slot screwdrivers, and others for engine disassembly
Expendable	Tie wraps, engine coolant
Replaceable	Coolant Hoses - reuse if serviceable, coolant
Service Rating	Heavy
Minimum Certification	LSA-RM with Rotax Maintenance certification or A&P with Rotax Maintenance certification
Additional References	KAI, Rotax Line and Heavy Maintenance Manuals

REMOVAL

▲ WARNING: ALLOW THE ENGINE AND APPLICABLE COMPONENTS TO COOL BEFORE PERFORMING SERVICE OR INSPECTION. HOT ENGINE COMPONENTS WILL CAUSE SERIOUS BURNS.

1. Remove the exhaust system, see Exhaust System chapter.
 2. Disconnect all wires and fuel pump drain tube from oil return tubes if/as required.
 3. Disconnect oil pressure, EGT, and CHT wires from cylinder heads as required.
- See Rotax Line and Heavy Maintenance Manuals for the remaining steps:
4. Drain coolant; remove intake manifolds, water hoses, valve covers, cylinders, pistons, and valve assemblies.

INSTALLATION

1. Installation is reverse of removal.
2. Refill coolant system to recommended level.

ENGINE REPLACEMENT

Tools	Torque wrench, many common tools as req'd.
Expendable	Loctite 221, coolant, engine oil
Replaceable	
Service Rating	Line
Minimum Certification	LSA-RM with Rotax Service certification or A&P with Rotax Service certification
Additional References	KAI, Rotax Line and Heavy Maintenance Manual

REMOVAL

1. Remove battery ground cable from negative battery terminal.
2. Remove exhaust system. See Exhaust System chapter.
3. Disconnect fuel pump drain tube and hose where attached to the engine.
4. Disconnect oil pressure, EGT, and CHT wires from cylinder heads. Cut tie-wraps securing wire runs to various engine components as required.
5. Move fuel selector valve to "UP-OFF" position.
6. Place suitable container under gascolator. Remove gascolator bottom plug and drain fuel from system. NOTE: This is a relatively slow process.
7. Disconnect fuel hose at firewall and gascolator. Some fuel may still be in hoses.
8. Place drain pan beneath engine and drain oil by disconnecting oil hose at pump. Elevate hose to prevent siphoning oil from tank.
9. Burp engine.
10. Disconnect oil return hose from bottom of engine case.
11. Disconnect oil return hose (where tank is marked "IN") from top of oil tank.
12. Drain cooling system per Rotax Line Maint. Manual.
13. Disconnect throttle and choke cables from carburetor per KAI.

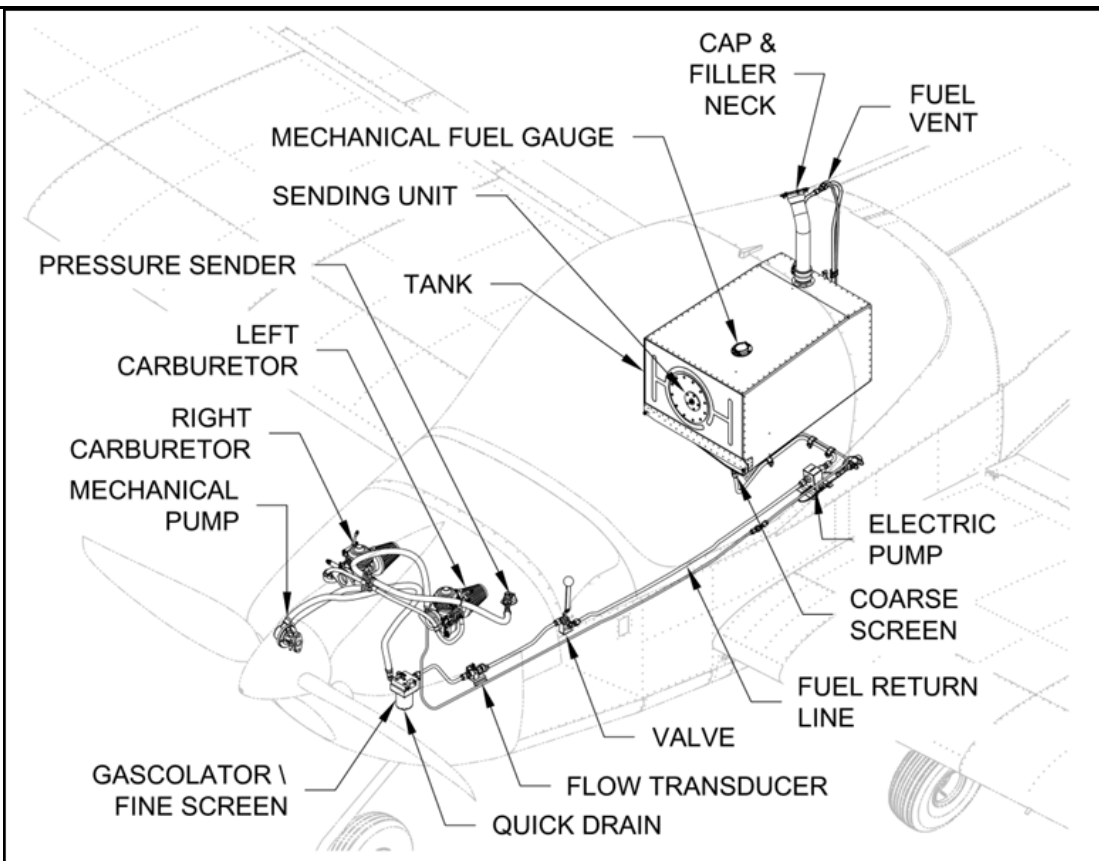
Refer to KAI for remainder of engine removal steps.

INSTALLATION

1. Installation is reverse of removal. Torque fasteners as specified.
2. Refill coolant system to recommended level.
3. Refill oil to recommended level.
4. Purge oil system, etc. refer to the Rotax Line Maintenance Manual for this and other procedures during and after installation. Also refer to applicable KAI sections throughout the installation.

THIS PAGE INTENTIONALLY LEFT BLANK

CHAPTER 13 - FUEL SYSTEM



OVERVIEW	13-2
Components	13-2
Fuel System Schematic.....	13-3
SERVICE	13-3
Supplies	13-4
Tools.....	13-4
Expendable.....	13-4
Replaceable.....	13-4
General	13-4
Draining the fuel system	13-4
Fuel tank removal	13-5
Installation	13-6
Fuel system component removal.....	13-6
Installation.....	13-7
Service Schedule Procedures	13-7
Gascolator cleaning.....	13-7
Installation.....	13-7
Fuel strainer removal.....	13-8
Installation.....	13-8
Fuel Return Assembly Replacement.....	13-8
Fuel Pressure Hose Flush.....	13-9
Fuel Drain Hose Replacement	13-10

OVERVIEW

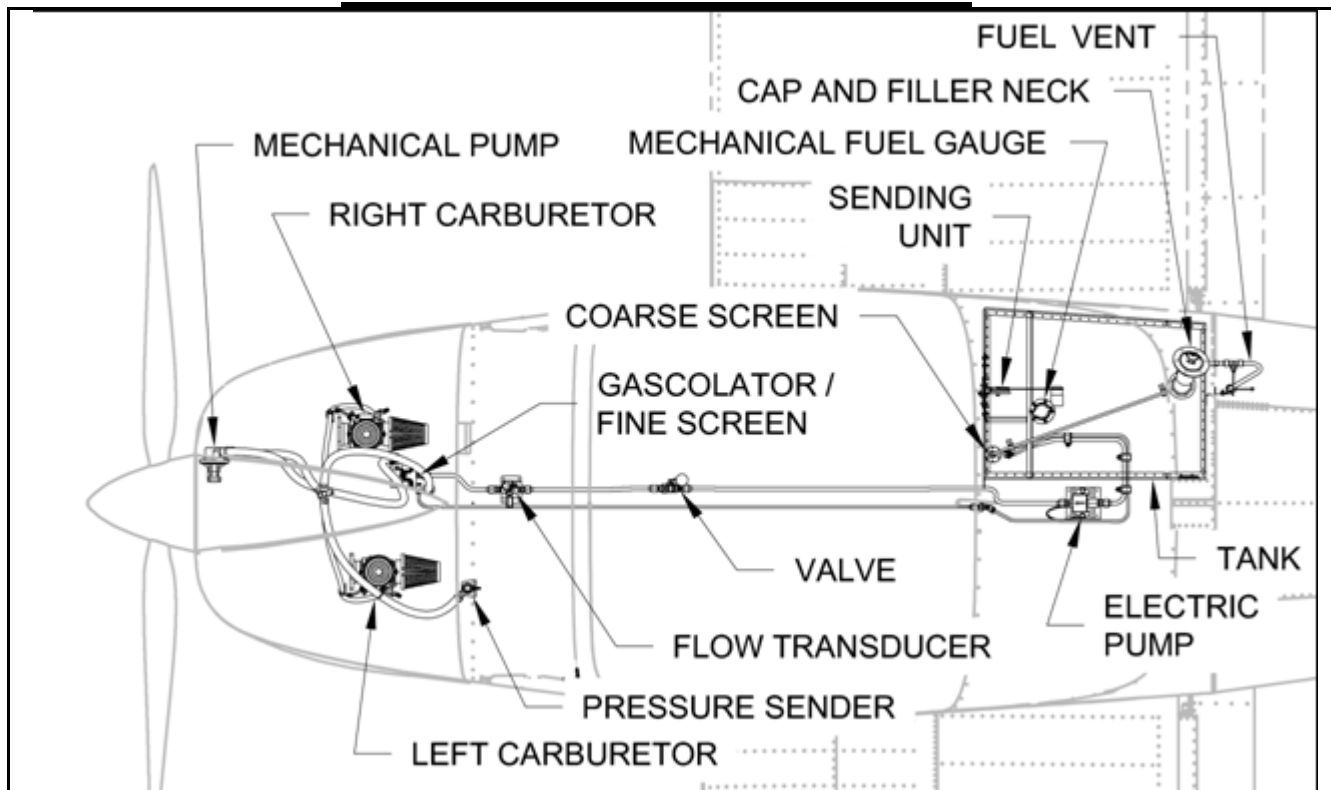
The fuel system consists of a fuel neck and cap, 20-gallon fuel tank, tank sending unit, mechanical fuel gauge and electric fuel pump aft of the center section. The ES 40105 Electric fuel pump is a 12V DC solid-state pump. This serves as an auxiliary fuel pump. The VA-261 Fuel Strainer at the outlet of the fuel tank prevents any large foreign objects from proceeding into the rest of the fuel system. Forward of the center section, in order; there is the fuel valve, fuel flow transducer, gascolator, Engine driven fuel pump, and the fuel manifold. The fuel valve provides the ability to permit or prevent fuel flow to the fuel system downstream of the fuel valve. The manifold feeds the fuel pressure sender, fuel return line and the left and right carburetors. The gascolator serves as the primary fuel filter and water trap. Sample the gascolator sump frequently to monitor the amount of water introduced into the fuel system. The gascolator and fine fuel screen requires inspection and cleaning at regular intervals (at least annually).

• **NOTE: This maintenance manual is intended to be used in conjunction with the RV-12 Kit Assembly Instructions (KAI) when completing maintenance or repair processes.**

COMPONENTS

Quantity	Part or Assembly Name	Part Number or Reference
1	Fuel cap	T-406A
1	Fuel neck	T-1211
1	Fuel tank	See KAI
1	Fuel strainer	VA-261
1	Electric fuel pump	ES 40105
1	Fuel valve	4161089
1	Gascolator	GAS-5
1	Fuel quick-drain	CAV-110
1	Fuel flow transducer	Flo-Scan or FT-60
1	Fuel sending unit	IE F-385B
1	Left carburetor	See Rotax Documentation
1	Right carburetor	See Rotax Documentation
1	Mechanical fuel pump	See Rotax Documentation
1	Fuel pressure sender	See KAI
1	Mechanical Fuel Gauge	IE-00001

FUEL SYSTEM SCHEMATIC



SERVICE

▲ **WARNING:** ALWAYS HAVE AN APPROPRIATE FIRE EXTINGUISHER READILY AVAILABLE.

▲ **WARNING:** BEFORE PERFORMING ANY MAINTENANCE OR REPAIRS TURN THE MASTER SWITCH 'OFF' AND DISCONNECT THE NEGATIVE (-) BATTERY CABLE FROM THE BATTERY.

■ **CAUTION:** REPLACEMENT FUEL SYSTEM COMPONENTS MUST BE EQUIVALENT TO THE ORIGINAL PARTS.

● **NOTE:** CLOSE THE FUEL VALVE TO SERVICE OR REMOVE COMPONENTS THAT ARE FORWARD OF THE FUEL VALVE. DRAIN THE FUEL SYSTEM TO SERVICE OR REMOVE COMPONENTS AFT OF THE FUEL VALVE.

SUPPLIES

TOOLS	EXPENDABLE
<ul style="list-style-type: none"> ◆ Sockets: <ul style="list-style-type: none"> ▪ 1/4 ▪ 3/8 ▪ 5/16 ▪ 7/16 ◆ Combination wrench: <ul style="list-style-type: none"> ▪ 3/8 ▪ 7/16 ▪ 1/2 ▪ 11/16 ▪ 3/4 ▪ 9/16 ◆ Screwdriver <ul style="list-style-type: none"> ▪ #2 Phillips ▪ 3/16 Standard ▪ Hex. flat blade screw bit ◆ Safety wire pliers ◆ Fuel Container ◆ 1/2 ID fuel hose 	REPLACEABLE
	<ul style="list-style-type: none"> ◆ Safety wire ◆ Gas-5 Screen ◆ Gas-5 O-ring gasket

GENERAL

▲ WARNING: ALWAYS HAVE AN APPROPRIATE FIRE EXTINGUISHER READILY AVAILABLE.

▲ WARNING: BEFORE PERFORMING ANY MAINTENANCE OR REPAIRS TURN THE MASTER SWITCH 'OFF' AND DISCONNECT THE NEGATIVE (-) BATTERY CABLE FROM THE BATTERY.

DRAINING THE FUEL SYSTEM

Tools	1/2, 3/4 combo wrench Fuel Container
Expendable	1/2 ID fuel hose
Replaceable	None
Service Rating	Preventative
Minimum Certification	Owner and SPC, LSA-RM or A&P
Additional References	KAI

● NOTE: IF THERE IS A FAIR AMOUNT OF FUEL IN THE TANK, REDUCE THE DRAIN TIME BY

FIRST SIPHONING OUT AS MUCH AS POSSIBLE. A SMALL WEIGHT SECURELY ATTACHED TO THE END OF A FLEXIBLE SIPHON HOSE WORKS WELL FOR REACHING THE TANK'S BOTTOM FORWARD END.

1. Put the fuel valve in the 'OFF' position.
2. Remove the engine cowling. (12-4)
3. Place a container beneath the gascolator with sufficient capacity for the fuel in the fuel tank.

● **NOTE: POSITION A RAG UNDER THE GASCOLATOR FITTING TO CATCH SPILLED FUEL . IMMEDIATELY AFTER DISCONNECTING THE HOSE MOVE IT UPWARD AND POSITION THE END AS HIGH AS POSSIBLE TO MINIMIZE THE LOSS OF FUEL FROM THE HOSE.**

4. Disconnect the fuel hose from the 90° fitting on the output side of the gascolator.
5. Temporarily connect a length of 1/2" ID hose to the 90° fitting. Place the loose end in the fuel container.
6. Put the fuel valve in the 'open' position.
7. Remove the fuel cap from the fuel neck.

■ **CAUTION: TURN OFF THE ELECTRIC FUEL PUMP IMMEDIATELY WHEN A CHANGE IN SOUND IS HEARD, (THE LOUDER CLACKING SOUND INDICATES THE FUEL PUMP IS NO LONGER PUMPING FUEL) DO NOT ALLOW THE FUEL PUMP TO OPERATE WITHOUT FUEL OR PERMANENT DAMAGE MAY OCCUR.**

8. Turn on the master switch and operate the ES 40105 Electric Fuel Pump until the fuel pump stops pumping fuel.
9. Put the fuel cap back in place in the fuel filler opening **but do not latch it**. Just allow the cap to lay in the opening. To aid in clearing the fuel lines use low pressure (5-10 PSI max) air applied to the open end of the fuel hose that was disconnected from the gascolator's outlet fitting.

Repeat the previous two steps several times, waiting for about 30 seconds between repetitions to give the fuel time to flow past the tank's internal baffle.

Also, the fuel valve may be partially closed, reducing the flow rate to equal or slightly less than the tank drainage rate (for fuel behind the internal baffle), helping to reduce the number of 'run - wait' cycles.

10. Reconnect the fuel line at the gascolator.

FUEL TANK REMOVAL

Tools	5/16, 3/8, 7/16 socket 11/16, 9/16 combo wrench
-------	--

	#2 Phillips screwdriver 3/16 Standard screwdriver
Expendable	None
Replaceable	None
Service Rating	Line
Minimum Certification	LSA-RM or A&P
Additional References	KAI

1. Drain the fuel system. (13-4)
2. Remove the two aft access covers from the fuselage bottom skin. (3-4)
3. Remove the screws (6) that attach the fuel neck to the fuselage. Loosen the hose clamps and slide the rubber collar up to remove the fuel neck from the fuselage and fuel tank.
4. Disconnect the fuel sending unit wire.
5. Remove the ELT Antenna Bracket, disconnect the coax cable and set aside.

■ CAUTION: DOUBLE WRENCH DURING THE REMOVAL OF THE SMALLER OF THE TWO FUEL LINES TO PREVENT ACCIDENTAL ROTATION OF THE FITTING IN THE FUEL TANK.

6. Disconnect the two fuel lines from the bottom of the tank.
7. Remove the two bolts from the forward fuel tank attach bracket.
8. Remove the bolt from the aft fuel tank attach bracket.
9. Remove the fuel tank.

INSTALLATION

1. Installation procedure is reverse of the removal procedure.

FUEL SYSTEM COMPONENT REMOVAL

▲ WARNING: BEFORE PERFORMING ANY MAINTENANCE OR REPAIRS TURN THE MASTER SWITCH 'OFF' AND DISCONNECT THE NEGATIVE (-) BATTERY CABLE FROM THE BATTERY.

Tools	3/8, 7/16 sockets 3/8, 7/16 combination wrenches
Expendable	None
Replaceable	None
Service Rating	Line
Minimum Certification	LSA-RM or A&P
Additional References	KAI

1. Isolate the component from fuel flow with either the fuel shutoff valve or by draining the fuel tank.

2. Label, then disconnect the electrical connections attached to the component, if applicable.
3. Disconnect the fuel line(s) attached to the component, if applicable.
4. Remove the attaching hardware and component.

INSTALLATION

1. Installation procedure is reverse of the removal procedure.

SERVICE SCHEDULE PROCEDURES

▲ WARNING: ALWAYS HAVE AN APPROPRIATE FIRE EXTINGUISHER READILY AVAILABLE.

GASCOLATOR CLEANING

Tools	3/16 Standard screwdriver 1/4" drive socket extension, 1/4" socket, flat blade screw bit Safety wire pliers Fuel catch container
Expendable	Safety wire
Replaceable	Gas-5 Screen Gas-5 O-ring gasket
Service Rating	Preventative
Minimum Certification	Owner and SPC, LSA-RM or A&P
Additional References	KAI

1. Remove the engine cowling. (12-4)
2. Move the fuel valve to the OFF position.
3. Remove the fuel quick-drain to drain the existing fuel from the gascolator bowl.
4. Remove the safety wire and screws (4) from around the gascolator bowl. **(Note: The inboard aft screw can be accessed through the hole provide in the bottom plate of the nose gear assembly by using a 1/4" drive socket extension, a 1/4" socket, and a screw bit inserted in the socket).**
5. Remove the collar and the gascolator bowl. **(Note: Have a container available to catch any spillage of fuel that still remains in the gascolator and fuel lines).**
6. Use a small pointed tool to lift the edge of the filter screen and remove it for cleaning.

INSTALLATION:

1. Installation procedure is reverse of the removal procedure.

FUEL STRAINER REMOVAL

Tools	3/4 combo wrench or deep socket
Expendable	Thread sealant paste
Replaceable	None
Service Rating	Line
Minimum Certification	LSA-RM or A&P
Additional References	KAI

NOTE: IT IS NOT NECESSARY TO REMOVE THE FUEL TANK IN ORDER TO REMOVE THE FUEL STRAINER.

1. Drain the Fuel System. (13-4)
2. Remove the two aft access covers from the fuselage bottom skin. (3-4)
3. Disconnect the fuel line (forward most fitting) from the bottom of the tank.
4. Remove the fuel strainer.
5. Clean the screen and inspect same for breakage or separation from fitting.

Installation:

1. Installation procedure is reverse of the removal procedure. Apply thread sealant paste to fuel strainer pipe threads before installation.

FUEL RETURN ASSEMBLY REPLACEMENT

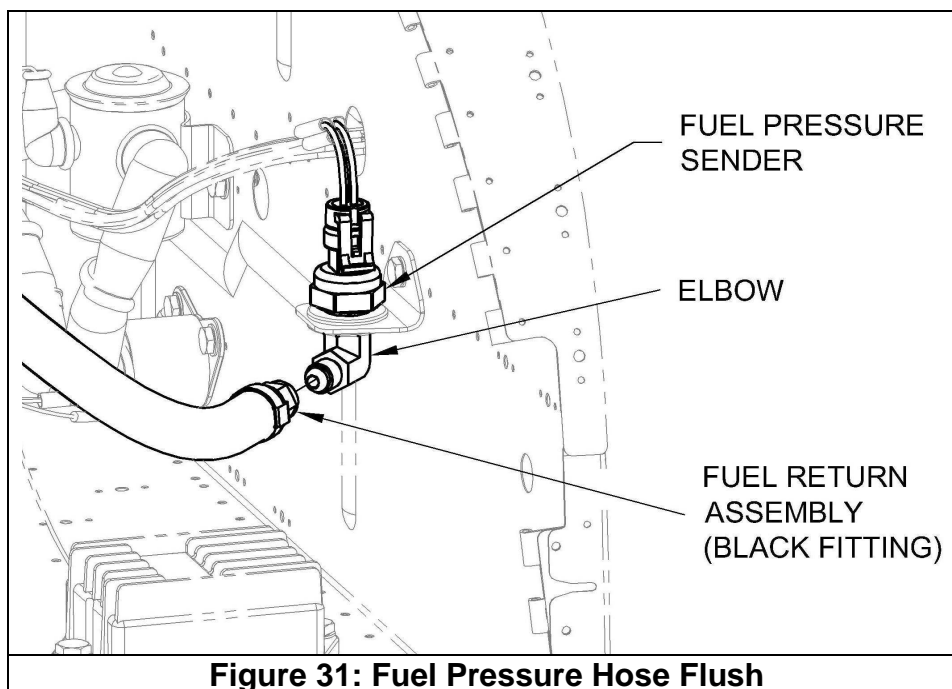
Tools	2X 9/16, 11/16, 7/8, 14mm open end wrench 12mm socket, torque wrench(in-lb) , wire cutters
Expendable	Plastic tie-wrap 8in
Replaceable	Fuel Return Assembly
Service Rating	Preventative
Minimum Certification	LSA-RM with Rotax Service certification of A&P with Rotax Service Certification
Additional References	KAI

NOTE: WHEN LOOSENING OR TIGHTENING THE BANJO BOLT SUPPORT THE CLAMP BLOCK (FUEL MANIFOLD) APPROPRIATELY.

1. Drain fuel system forward of fuel valve. (13-4)
2. Disconnect both ends of Fuel Return Assembly.
3. Remove banjo bolt M8X1X17 from top of clamp block.
4. Cut tie-wraps and remove Fuel Return Assembly.

Installation:

1. Installation of new hose assembly is reverse of removal procedure. Rotax specifies that new copper crush washers be used.
2. Torque banjo bolt M8X1X17 to 90 in-lbs.



FUEL PRESSURE HOSE* FLUSH (* Left Side of Fuel Return Assembly)

Tools	2X 9/16 combination wrenches
Expendable	Fuel, rags, temporary fuel container
Replaceable	NA
Service Rating	Preventative
Minimum Certification	LSA-RM with Rotax Service certification or A&P with Rotax Service certification
Additional References	KAI

Removal

1. Place rags beneath the Fuel Pressure Sender.
2. Loosen VA-216 Fuel Return Assembly hose coupling while supporting elbow with second wrench.
3. Place container beneath hose and remove hose from fitting.
4. With end of hose inside container, flush hose by turning on fuel boost pump for two seconds.

Installation

1. Reinstall hose to elbow.

FUEL DRAIN HOSE REPLACEMENT

Tools	1/4 socket or Phillips screwdriver
Expendable	Tie wraps (2)
Replaceable	Fuel interconnect and drain hoses
Service Rating	Preventative
Minimum Certification	LSA-RM with Rotax Service certification or A&P with Rotax Service certification
Additional References	KAI

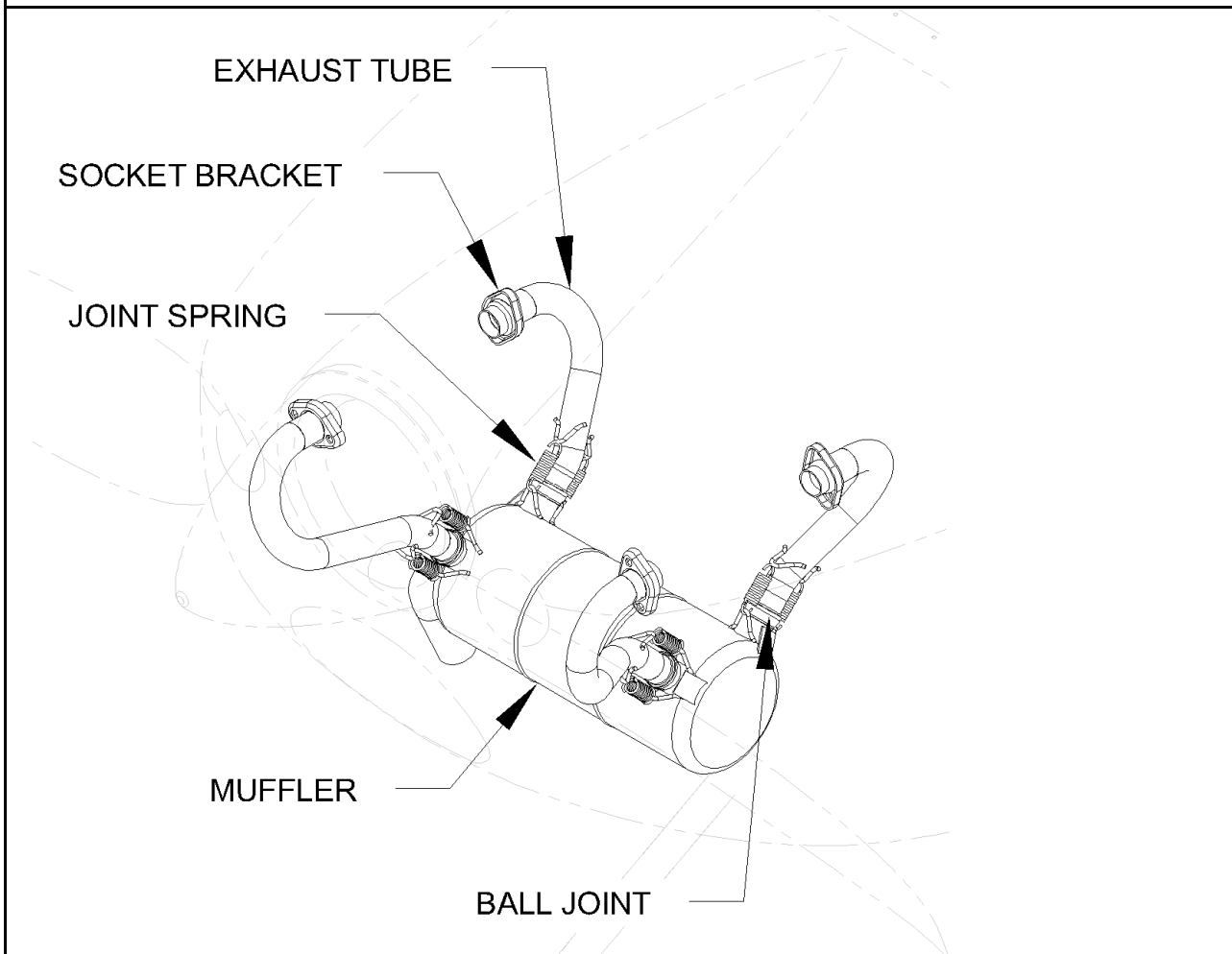
Removal

1. Cut the tie wraps attaching the drain hose to the gascolator-to-fuel-pump hose.
2. Loosen two hose clamps on the interconnect hose and one clamp on the drain hose and slide the clamps onto the aluminum drain tube.
3. Remove the hoses.

Installation

1. Install new hoses onto the fuel pump drain fitting and the drain tube.
2. Slide hose clamps back into position over the hoses and tighten.
3. Secure the drain hose to the gascolator-to-fuel-pump hose using tie wraps.

CHAPTER 14 - EXHAUST SYSTEM



OVERVIEW	14-2
Components	14-2
SERVICE	14-2
Supplies	14-2
Tools	14-2
Expendable	14-2
Replaceable	14-2
General	14-3
Exhaust system removal	14-3
Installation	14-3
Service Schedule Procedures	14-4
Ball joint lubrication	14-4

OVERVIEW

The primary purpose of the exhaust system is to direct engine combustion gasses and heat away from the aircraft, components and occupants. The purpose of the muffler is to reduce engine noise.

• **NOTE: THIS MAINTENANCE MANUAL IS INTENDED TO BE USED IN CONJUNCTION WITH THE RV-12 KIT ASSEMBLY INSTRUCTIONS (KAI) WHEN COMPLETING MAINTENANCE OR REPAIR PROCESSES.**

COMPONENTS

Quantity	Part or Assembly Name	Part Number or Reference
4-SB "1"	Cylinder #x Exhaust	EX-00015, EX-00016, EX-00017, EX-00018,
1	Muffler	EXH-12
8	Joint spring	938-795
8	Exhaust M8-WS12 Lock Nut	842 950

SERVICE

SUPPLIES

TOOLS	EXPENDABLE
<ul style="list-style-type: none"> ◆ 13 mm socket ◆ Locking pliers 	<ul style="list-style-type: none"> ◆ Anti-seize compound, high temp ◆ Exhaust M8-WS12 Lock Nuts
	REPLACEABLE
	<ul style="list-style-type: none"> ◆ See component list above except M8 Nuts.

GENERAL

EXHAUST SYSTEM REMOVAL

▲ WARNING: ALLOW THE EXHAUST COMPONENTS TO COOL BEFORE PERFORMING INSPECTION OR SERVICE.

Tools	13 mm socket Locking pliers
Expendable	Anti-seize compound, high temp
Replaceable	Joint spring M8-12WS Nuts
Service Rating	Line
Minimum Certification	LSA-RM or A&P
Additional References	KAI

1. Remove the engine cowling. (12-4)
2. Remove the muffler attachment springs (8) and muffler. Note: To avoid nicking the springs clamp a short loop of safety wire in locking pliers. Hook the loop onto the spring and then pull to remove the spring.
3. Remove the two nuts, two washers and the exhaust tube from each cylinder exhaust port.

INSTALLATION

1. Lubricate the ball joints and all exhaust hardware. (14-4)
2. Installation procedure is reverse of the removal procedure.

SERVICE SCHEDULE PROCEDURES

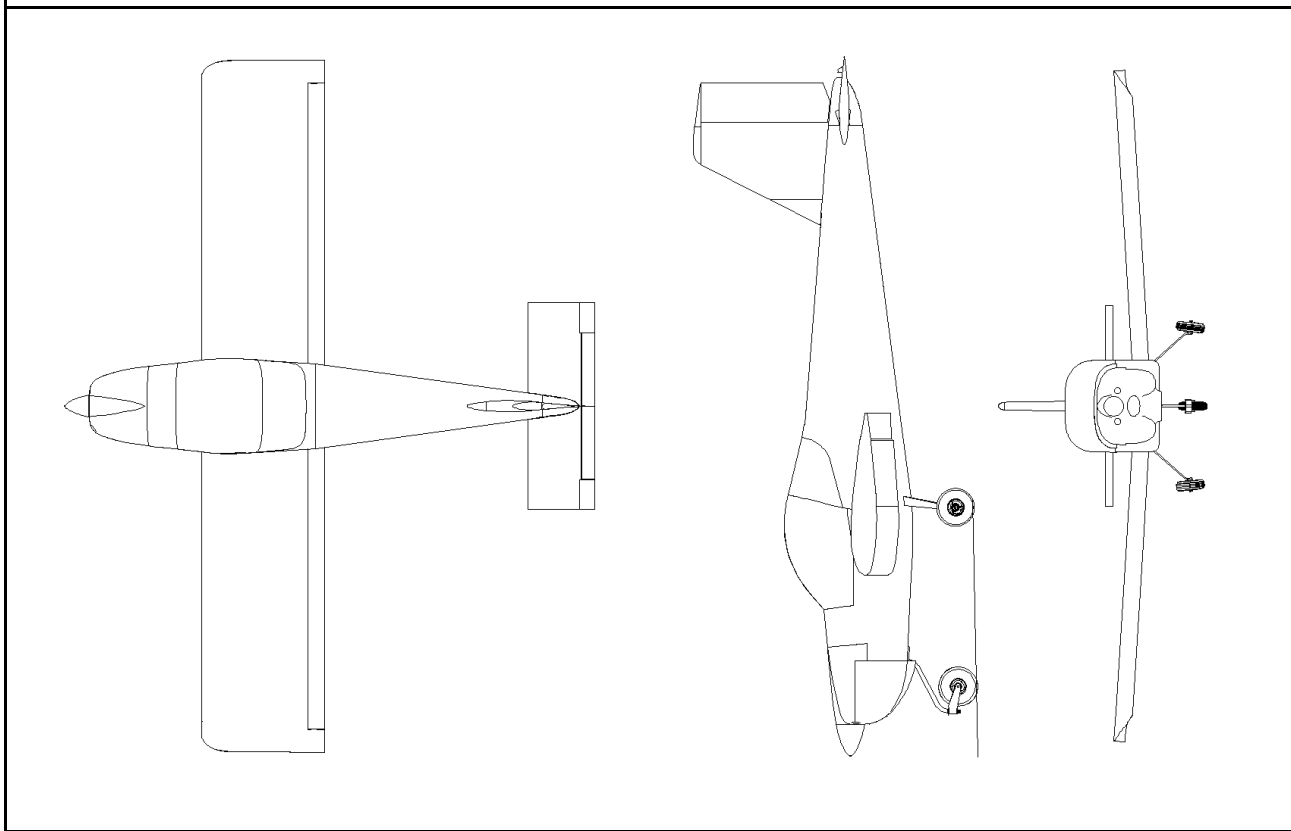
BALL JOINT LUBRICATION

▲ WARNING: ALLOW THE EXHAUST COMPONENTS TO COOL BEFORE PERFORMING INSPECTION OR SERVICE.

Required tools	Locking pliers
Required expendables	Anti-seize compound
Replaceable	None
Service rating	Line
Minimum Certification	LSA-RM or A&P
Additional Reference	KAI

1. Remove the muffler attachment springs (8) and muffler. **Note: Use locking pliers for a tight grip on the springs during removal and installation.**
2. Apply a generous amount of lubricant to the exhaust tube where it meets the muffler flange.
3. Reinstall the muffler.

CHAPTER 15 - PAINTING AND COATINGS



OVERVIEW	15-2
SERVICE	15-3
Supplies	15-3
Tools.....	15-3
Expendable.....	15-3
Replaceable.....	15-3
Service Schedule Procedures	15-3
Powder coat repair	15-3
Primer repair.....	15-4
Decorative paint repair	15-5

OVERVIEW

• **NOTE: REFER TO KAI – SECTION 4 AND 5 FOR ADDITIONAL INFORMATION.**

The aluminum skins used on RV aircraft are all 2024-T3 alloy. They are "alclad" meaning both sides of the sheet are coated with pure aluminum during manufacture. The thickness of the alclad layer on aluminum sheet 1/16 inch thick or less is 5% of the sheet thickness. Alclad on aluminum sheet greater than 1/16 inch thick is 2.5% of the sheet thickness.

All non-alclad aluminum parts such as 6061-T6 must be primed for corrosion protection. Aluminum tubing (other than fluid lines) must be primed on both the interior and exterior surfaces.

Aluminum bar, angle and tube used in the RV-12 are not alclad and must be primed to ensure corrosion resistance. Zinc Chromate has been the traditional primer used on aircraft aluminum. With proper surface cleaning this is still a good choice. There are however many superior primers now available. Most of these are two part, catalytic curing primers. Generally speaking it's preferable to replace a coated part with a coated part.

Following is a partial list of suitable primers:

- ♦ *DUPONT VERI-PRIME (PRIMER #615 and CONVERTER #616S)*
- ♦ *DITZLER DP-40/50 EPOXY PRIMER*
- ♦ *TEMPO brand Chromate in a spray can*
- ♦ *PRATT & LAMBERT Vinyl Zinc Chromate, EX-ER-7 and T-ER-4 Reducer*
- ♦ *SHERWIN WILLIAMS WASH PRIMER #P60G2 and Catalyst Reducer #R7K44*
- ♦ *MARHYDE self-etching primer, available in a spray can as well as quarts*

Decorative paint on the structure of the aircraft can be touched-up by the sport pilot certified owner or a certified repairman with 'maintenance' rating. Control surfaces can only be repainted by an LSA repairman with a 'maintenance' rating or an A&P.

Part replacement must be consistent with the original KAI from Van's Aircraft. Priming factory alclad replacement parts remains at the repairman's discretion. Non-alclad parts must be primed per the KAI. Any parts that require replacement due to corrosion warrant additional corrosion protection on the replacement part. When in doubt, prime the part.

SERVICE

▲ WARNING: PAINT OR SOLVENT MUST USED IN ACCORDANCE WITH THE MANUFACTURERS INSTRUCTIONS.

▲ WARNING: DO NOT USE ANY TYPE OF BODY FILLER ON THE AIRCRAFT.

▲ WARNING: DO NOT DAMAGE ANY RIVET HEADS WHEN PREPARING A SURFACE FOR TOUCH-UP PAINT.

■ CAUTION: EXPOSED STEEL MUST BE CLEANED AND COATED WITH PRIMER OR POWDER COAT TOUCH-UP PAINT.

■ CAUTION: ANY SCRATCH THAT MAY HAVE PENETRATED THE ALCLAD COATING MUST BE CLEANED AND PRIMED PROPERLY.

SUPPLIES

TOOLS	EXPENDABLE
<ul style="list-style-type: none"> ◆ Scouring pad ◆ Sandpaper (various grades) 	<ul style="list-style-type: none"> ◆ Touch-up paint ◆ Primer ◆ Decorative touch-up paint
REPLACEABLE	
<ul style="list-style-type: none"> ◆ None 	

SERVICE SCHEDULE PROCEDURES

POWDER COAT REPAIR

▲ WARNING: IF CRACKS, PENETRATING RUST OR CORROSION ARE FOUND IN THE COATING SURFACE OF POWDER-COATED, PRIMED OR PAINTED PARTS, THE PART SHOULD BE CAREFULLY INSPECTED UNDER THE COATING FOR MATERIAL DAMAGE. IF IN DOUBT THE PART SHOULD BE REPLACED.

Tools	Sandpaper
Expendable	Touch-up paint
Replaceable	None
Service Rating	Line
Minimum Certification	Total area 4 in ² or less - Owner and SPC Total area greater than 4 in ² - LSA-RM or A&P
Additional References	KAI

1. Use coarse grit sandpaper to remove the entire area of loose, stained or cracked coating. Discolored powder coat could conceal underlying rust damage and requires removal.
2. Gradually progress to finer grit sandpaper to achieve a smooth, gradual taper to undamaged coating.
3. Clean and dry the entire prepared area.
4. Apply touch-up paint to the entire prepared area.

PRIMER REPAIR

• NOTE: WHEN PRIMING A REMOVABLE PART BETTER RESULTS CAN BE ACHIEVED BY REMOVING THE PART.

Tools	Sandpaper
Expendable	Primer
Replaceable	None
Service Rating	Line
Minimum Certification	Static structure: Total area 56 in ² or less - Owner and SPC Total area greater than 144 in ² - LSA-RM or A&P Control surface: Total area 10 in ² or less - Owner and SPC Total area greater than 10 in ² - LSA-RM or A&P
Additional References	KAI

1. Remove any loose or damaged primer.
2. Use progressively finer grit sandpaper to achieve a smooth, gradual taper to undamaged primer.
3. Clean and dry the entire prepared area.
4. Apply primer to the entire prepared area.

DECORATIVE PAINT REPAIR

■ **CAUTION: ANY SCRATCH THAT HAS PENETRATED TO THE METAL MUST BE CLEANED AND PRIMED PRIOR TO APPLYING DECORATIVE PAINT.**

● **NOTE: WHEN PRIMING A REMOVABLE PART BETTER RESULTS CAN BE ACHIEVED BY REMOVING THE PART.**

Tools	Sandpaper
Expendable	Applicable touch-up paint
Replaceable	None
Service Rating	Line
Minimum Certification	<p>Static structure: Total area 64 in² or less - Owner and SPC Total area greater than 64 in² - LSA-RM, or A&P</p> <p>Control surface: Total area 16 in² or less - Owner and SPC Total area greater than 16 in² - LSA-RM, or A&P</p>
Additional References	KAI

1. Remove any loose or damaged paint.
2. Use progressively finer grit sandpaper to achieve a smooth, gradual taper to undamaged paint.
3. Clean and dry the entire prepared area.
4. Apply primer and touch-up paint to the entire prepared area.

THIS PAGE INTENTIONALLY LEFT BLANK

CHAPTER 16 - TROUBLESHOOTING

Symptom	Possible Causes	Related Chapter
Recurring blown fuse	<ul style="list-style-type: none"> ◆ Short in circuit ◆ Overloaded circuit 	8
Engine will turn over, fails to start	<ul style="list-style-type: none"> ◆ Insufficient ignition source ◆ Insufficient fuel supply to engine ◆ Insufficient air supply to engine 	8 13 12
Engine fails to turn over	<ul style="list-style-type: none"> ◆ Insufficient battery power ◆ Blown 'Start' fuse ◆ Master or starter relay malfunction ◆ Starter malfunction 	8
Heater air is cool	<ul style="list-style-type: none"> ◆ Low engine coolant ◆ Engine below operating temperature. ◆ Blockage in coolant system ◆ Air leak around heater box 	12
Vent door stuck	<ul style="list-style-type: none"> ◆ Damage to fuselage ◆ Damage to vent ◆ Over tightened vent hardware 	3 5 KAI
Wing attach pin very difficult to insert or remove	<ul style="list-style-type: none"> ◆ Insufficient lubrication ◆ Structural damage ◆ Wing not fully inserted ◆ Force applied to wing 	5 3 5
Pulls to one side during taxiing (level surface)	<ul style="list-style-type: none"> ◆ Low tire pressure ◆ Dragging brake ◆ Damage to landing gear ◆ Axle nut over tightened 	1 7 KAI KAI
Difficult to turn while taxiing	<ul style="list-style-type: none"> ◆ Brake malfunctioning ◆ Nose fork over tightened 	7 KAI
Shudder after touch-down	Nose fork under tightened	5

Symptom	Possible Causes	Related Chapter
Vibration at idle	<ul style="list-style-type: none"> ◆ Propeller installed incorrectly ◆ Idle RPM too low ◆ Carb. synchronization out of balance ◆ Engine suspension loose 	11 12 Rotax line maint. 3
Vibration at specific RPM	<ul style="list-style-type: none"> ◆ Carburetor malfunction ◆ Ignition malfunction 	12 Rotax line maint.
Excessive rattling	<ul style="list-style-type: none"> ◆ Loose fasteners ◆ Loose baggage 	3
Corrosion	<ul style="list-style-type: none"> ◆ Loose electrical connection ◆ Exposure to contamination ◆ Failing protective coating ◆ Unlike metals exposed to moisture 	8 3 15 15
Flight control resistance	<ul style="list-style-type: none"> ◆ Insufficient lubrication ◆ Control surface hinge axis not aligned ◆ Failing control system components ◆ Improper control system adjustments 	2 5-17 6 KAI
Erroneous engine status	<ul style="list-style-type: none"> ◆ Malfunctioning sensor ◆ Loose connection ◆ Malfunctioning EMS 	8 3 9
Abnormal engine noise	<ul style="list-style-type: none"> ◆ Damaged or leaking exhaust system ◆ Open passage in firewall 	14 3

CHAPTER 17 - FEEDBACK & REPLACEMENT PARTS

FEEDBACK

To maintain the highest level of safety the FAA requires and Van's Aircraft Inc. requests notification of any safety of flight issue, service or maintenance difficulty that could compromise airworthiness of the RV-12 aircraft. **A feedback form is provided in the Supplement section of this manual.**

A valuable description will include:

- Specific flight condition if applicable.
- List of the parts identified as affected by the anomaly.
- Description of the apparent condition of the parts prior to the anomaly (de-burred, primed, modified, etc.)
- Statement as to whether the aircraft has remained within the operating limitations defined in the POH.
- Brief description of the type and frequency of aircraft use (may include; runway conditions, flying conditions, storage methods, etc.)

REPORTING METHODS

Mail to:

ATTN: RV-12 Safety Alert
Van's Aircraft, Inc.
14401 Keil Road, NE
Aurora, OR 97002 USA

Fax to:

'RV-12 Safety Alert' (on cover page)
503.678.6560
Hours: 24 hours per day

E-mail to:

'RV-12 Safety Alert' (in subject line)
engineering@vansaircraft.com

REPLACEMENT PARTS

Van's Aircraft Inc. reserves the right to update, modify or discontinue any part without notice. Van's Aircraft Inc. is not liable for the use of any part or material by the owner that does not appear on the kit's part list. Use of any unauthorized part or material will be at the owner/operators own risk.

For replacement parts contact Van's Aircraft Inc. using the following information:

Van's Aircraft, Inc.
14401 Keil Road, NE
Aurora, OR 97002 USA

Phone: 503.678.6545
Fax: 503.678.6560
Website: www.vansaircraft.com
email: orders@vansaircraft.com

Part number and description may be obtained from the Kit Assembly Instructions. Whenever ordering replacement parts please provide the following information:

- Name
- Builder Number
- Day Phone
- Fax (if applicable)
- Email
- Ship to Address:
 - Address
 - City
 - State/Province
 - Zip/Postal Code
 - Country
- part number
- description
- quantity
- payment method and corresponding account #, & exp. date (if applicable)

SUBSTITUTE PARTS

The following parts are approved for substitution. Either the original part or substitute part is acceptable for installation in the aircraft.

Brake System

F 271-N-04X02 Male Nylon Tee ↔ Van's FLF-00004 Male Nylon Tee ↔ MCMASTER-CARR 5779K204 ↔ LEGRIS 3103 56 11

Avionics System

FN4MC-2 Nylon 1/4 Straight ↔ Van's FLF-00007 Elbow ↔ MCMASTER CARR 5779K151 ↔ LEGRIS 3109 56 11

SV-D1000 (T) ↔ SV-HDX1100

Oil System (*Note: There was no 'original part' in this case.*)

FUMOTO F107N 12mm-1.75 Quick Oil Drain Plug ↔ CCA-2450 Valve and CCA-2474 Extension ↔ SAF-AIR M12175 Valve and RM12175 Extension.

Torx Drive Screw

AN526C832-R8 Phillips Truss SS X 1/2 in ↔ Fastenal 0175181 Torx, Pan Head, SS X 1/2 in (0175180, 3/8 in) NOTE: May be used in place of screws that hold all interior panels.

Rivets

AN470AD rivets may be substituted for specified LP4 rivets.

AN426AD4 rivets may be substituted for specified CS4 rivets

Cherry Max CR series rivets may be substituted for any AN470AD rivet or LP4 rivet.

CCR rivets and solid AN426AD3 rivets, used for attaching nutplates, may be used interchangeably. AN426AD3 rivets are preferred for strength wherever they can be accommodated.

THIS PAGE INTENTIONALLY LEFT BLANK

CHAPTER 18 - SUPPLEMENT

SERVICE SCHEDULE CHECKLIST.....18-3
INSPECTION CHECKLIST.....18-7
ELECTRICAL SYSTEM SCHEMATIC.....18-23
3 VIEW.....18-25
FEEDBACK FORM.....18-27

THIS PAGE INTENTIONALLY LEFT BLANK

SERVICE SCHEDULE CHECKLIST

What	Action	When	How	Service Date	Initial
Aircraft	Inspection	Annual or 100 hours	3-1		
AST attach hinge	Lubricate	Annual or 100 hours	5-24		
Battery	Charge	As needed	8-13		
Battery terminals	Clean	As needed	8-13		
Brake fluid	Flush & replace	5 years	7-5		
Brake pedal components	Lubricate	2 years or 200 hours	7-4		
Brake shoe linings	Replace	As needed	7-6		
Cable end hardware	Lubricate	Annual or 100 hours	6-8		
Control system rod ends	Lubricate	Annual or 100 hours	6-8		
Coolant Hoses	Replace	5 years	12-15		
Dynon	Check for updates	Annual or as needed	Dynon user's manual		
ELT	Self-Test	3 Months	See Mfr's Manual		
ELT	Inspection	12 Months	See Mfr's Manual		
ELT Remote Control Panel Battery Alkaline	Replace	5 years	See Mfr's Manual		
ELT Remote Control Panel Battery Lithium	Replace	10 years	See Mfr's Manual		
ELT Audio Alert Indicator Battery	Replace	10 years	See Mfr's Manual		
Engine service procedures	Check & perform	100 hours	Rotax maintenance manual		
Exhaust ball joints	Lubricate	Annual or 100 hours	14-4		
Flaperon bearings	Lubricate	6 months or as needed	5-24		
Flaperon control connection	Lubricate	Each removal	5-23		
Fuel Drain Hose	Replace	5 years or with fuel pump	13-10		
Fuel Strainer	Clean & inspect	Annual or 100 hours	13-8		

THIS PAGE INTENTIONALLY LEFT BLANK

SERVICE SCHEDULE CHECKLIST (CONTINUED)

What	Action	When	How	Service Date	Initial
Fuel Drain Interconnect	Replace	5 years or with fuel pump	13-10		
Fuel Return Assembly	Replace	10 years or engine overhaul	13-8		
Fuel Pressure Hose	Flush	Annual or 100 hours	13-9		
Garmin	Check for updates	Annual or 100 hours	Garmin user's manual		
Gascolator	Clean	Annual or 100 hours	13-7		
Landing gear attach hardware	Torque	Annual or 200 hours	3-11		
Main wheel bearings	Lubricate	2 years or as needed	5-25		
Manifold Pressure Hose	Replace	10 years or engine overhaul	12-16		
Nose fork pivot	Lubricate	Annual or 100 hours	5-26		
Nose wheel bearings	Replace	As needed	5-24		
Wheel Balance	Balance	As needed	5-26		
Oil Supply Hoses	Replace	10 years or engine overhaul	12-14		
Propeller Hub Clamping Bolts	Torque	Annual or 100 hours	11-3		
Wing attach locations	Lubricate	Each removal	5-23		
Wing interface terminal tabs	Clean	Annual or 100 hours	8-13		
Throttle Return Springs	Verify Function	50 hours or after carburetor maintenance	12-14		
Throttle Return Springs	Replace	100 hours	12-15		
End of service schedule					

THIS PAGE INTENTIONALLY LEFT BLANK

INSPECTION CHECKLIST

RV-12 Aircraft Inspection

Reg. Number:	
Airframe S/N:	Engine S/N:
Airframe TT:	Engine TT:
Inspection Date:	Inspector:

Check all that apply to inspector and inspection:

Owner Operator Pilot A&P LSA Repairman Inspection LSA Repairman Maintenance
 100 hour Annual Extreme Conditions After Hard Landing

Category:

Check:

Documents		Pass	Fail
Certificate of Airworthiness	Onboard and Displayed		
Registration	Onboard and Accurate		
POH	Onboard		
Operating Limitations	Onboard		
Switch and control placards	Secure / Legible		
Identification Plate	Secure / Legible / Accurate		
Light Sport Placard (Experimental for E-LSA)	Displayed		
Weight & Balance / Equipment List	Onboard		
Service Schedule	Items due for service		

Systems & Controls Test

Operations / Values

Pre-Inspection

Post-Inspection

Engine Start Procedure	Effective / Complete		
Starter	Operational / Strong		
Oil Pressure & Temperature @ 1800 RPM			
Engine Run-Up	Refer to Rotax Line Maintenance Manual		

Continued next page

THIS PAGE INTENTIONALLY LEFT BLANK

Oil Pressure & Temperature	Pre-Values: Pressure_____ Temp_____		
	Post-Values: Pressure_____ Temp_____		
Left and Right CHT (idle & operating temp)	Pre-Values: Left_____ Right_____		
	Post-Values: Left_____ Right_____		
Left and Right EGT (idle & operating temp)	Pre-Values: Left_____ Right_____		
	Post-Values: Left_____ Right_____		
Left and Right Wing	Secure / Smooth operation of ailerons and flaps		
Brake System	Operation		
Fuel	Correct Indication		
Idle RPM at normal operating temp.	_____ @ RPM		
Verify function of throttle return springs	Springs pull throttle to wide open with friction control off (see procedure page 12-14)		
Static RPM at full throttle	Operational / RPM _____		
Electrical System	Operational / Volts: _____		
	Amps: _____		
Cool Down & Shut Down	Effective / Normal		
Fluids (Oil, Hydraulic, Fuel, Coolant)	Leak / Level Check		
Stall warning	Tone present in headphones when stall sense switch is lifted		
Angle-Of-Attack System	Pressure Check		

Continued next page

THIS PAGE INTENTIONALLY LEFT BLANK

Notes:

Cockpit	Check	Pass	Fail
Aft Face of Firewall	Cracks / Deformation		
Canopy Latch	Security / Cracks / Proper operation		
Fwd & Aft Canopy	Cracks / Deformation / Deterioration		
Pre-Inspection procedure	Step 1-5 (Page 3-3)		
Seats & Seat/Shoulder Harness	Wear / Fraying		
Cockpit Control Markings	Clear / Correct		
Roll Bar and canopy frame	Cracks / Deformation		

Continued next page

THIS PAGE INTENTIONALLY LEFT BLANK

Cockpit Control markings	Clear / Correct		
Control Panel	Security / Connections		
Fuses	Security / Condition / Spares		
Control Cable Links & Push / Pull Rods	Tension / Wear / Fatigue		
Control Stops	Security / Deformation / Alignment		
Flight Control Cables	Swages / Kinks / Interference / Alignment		
Engine Control Cables	Operation / Kinks / Interference / Alignment		
Cable Pulleys	Smooth Operation / Alignment / Security		
Control Stick	Smooth Operation		
Flap Lever	Smooth Operation		
Air & Heat Vents	Operation / Security		
Wiring Harness	Condition / Connections / Continuity		
System Lines (Fuel, Brake, Static)	Security / Routing / Condition / Fittings		
Fuel System Components	Security / Leaks		
Fuel Strainer	Clean/Secure		
Rudder Pedals & Brakes	Operation / Security		
Avionics & Radio		Inspect per Manufacturer Manual	
		Pass	Fail
Each Main Unit	Condition / Security		
Wiring & Conduit	Chafing / Routing / Security		
Connections	Corrosion / Security		
Antenna Mounts	Condition / Security		
Optional Equipment Throughout		Inspect per Manufacturer Manual	
		Pass	Fail

Continued next page

THIS PAGE INTENTIONALLY LEFT BLANK

Emergency Locator Transmitter	Comply with current FAR 91.207	Pass	Fail
"G" Switch	Also refer to current CFR 91.207		
Calendar date	Also refer to current CFR 91.207		
Battery Condition	Also refer to current CFR 91.207		
Audio Alert Indicator Battery	See Manufacturer's Manual		
Remote Control Panel Ind. Battery	See Manufacturer's Manual		
Self-Test	See Manufacturer's Manual		
<hr/>			
Propeller	Refer to Sensenich Manual	Pass	Fail
Spinner / Back-plate	Cracks / Deformation		
Blades	Delamination / Cracks / Damage		
Hardware	Condition / Torque		
Hub	Fasteners / Security		
Gear Box	Leaks / Fasteners / Security		
Prop Track	Perpendicular to Axis		

Continued next page

THIS PAGE INTENTIONALLY LEFT BLANK

Engine	Refer to Rotax Manual	Pass	Fail
Engine and components	Comply with Rotax manufacturer inspection recommendations (Rotax Line Maintenance Manual)		
<hr/>			
Firewall Forward	Fasteners / Deformation / Corrosion	Pass	Fail
Fwd Face of Firewall	Deformation / Cracks / Unsealed holes		
Studs & Nuts	Torque / Condition		
Engine Mount	Cracks / Signs of Fatigue / Corrosion		
Vibration Isolators	Cracks / Deterioration		
Mount & Isolator Hardware	Condition / Torque		
Wiring Harness	Condition / Connections / Continuity		
Battery	Condition / Corrosion / Security / Charge		
Cylinder Cooling Shroud	Security / Condition		
Cabin Heat Door	Security / Condition / Operation		
Left Carburetor	Condition / Secure Connections		
Right Carburetor	Condition / Secure Connections		
Carburetor Drip Trays	Cracks / Deformation		
System Lines (Fuel, Pitot)	Security / Routing / Condition		
Gascolator	Security / Contamination / Leaks		
Control Cables (throttle, choke, etc)	Operation / Condition / Connection		
Air Filters (left & right)	Clean / Secure		
Heat Exchangers (oil & coolant)	Leaks / Condition / Security		
Exhaust System	Leaks / Condition / Security		
Cowling	Condition / Fasteners		
<hr/>			
Empennage	Fasteners / Attachment / Corrosion	Pass	Fail
Vertical Stabilizer	Deformation / Cracks / Signs of Wear / Corrosion		
Rudder and bellcrank tube interior	Deformation / Cracks / Signs of Wear / Corrosion		
Stabilator and c' balance tube interior	Deformation / Cracks / Signs of Wear / Corrosion		

Continued next page

THIS PAGE INTENTIONALLY LEFT BLANK

Fuselage	Fasteners / Corrosion / Deformation	Pass	Fail
Skins	Deformation / Cracks / Signs of Wear / Corrosion		
Footprint Area of Left & Right Wing	Signs of Wear		
Bulkheads & Stringers	Deformation / Cracks / Signs of Wear / Corrosion		
Left & Right Static Ports	Clean / Clear / Secure		
Left & Right Boarding Step	Security / Seal		
Landing Gear			
	Fasteners / Corrosion / Refer to Matco manual	Pass	Fail
Main Gear Legs / Brackets	Security / Wear / Corrosion or Bubbled Paint		
Landing Gear Attach Hardware	Torque		
Brake Hydraulic Lines	Leaks / Security		
Wheel Bearings	Lubrication / Free Play / Refer to Matco manual		
Brake Calipers	Condition / Refer to Matco manual		
Brake Shoes	Lining Limit / Refer to Matco manual		
Brake Disks	Cracks / Deformation / Refer to Matco manual		
Wheels	Alignment / Cracks / Refer to Matco manual		
Tires & Valve Stem	Wear / Cracks / Air Pressure		
Nose Gear and Fork	Travel / Security / Break-out Force / Internal* Cor.		
Wings / Center Section			
	Fasteners / Corrosion / Deformation	Pass	Fail
Skins	Deformation / Cracks / Signs of Wear / Corrosion		
Ribs & Attach Angles	Deformation / Cracks / Signs of Wear / Corrosion		
Main, Fwd & Aft Spars	Deformation / Cracks / Signs of Wear / Corrosion		
Flaperon and Torque Tubes	Smooth Operation / Security / (Internal* Corrosion)		
Hinges	Smooth Operation / Lubrication		
Stall Warning	Secure / Connection / Condition		
Wing Retention Pins & Bushings	Signs of Fatigue / Wear / Maximum I.D. 1.505 inch		
Center Section (Channel & Bulkheads)	Deformation / Cracks / Signs of Wear / Corrosion		

* tube interior

Continued next page

THIS PAGE INTENTIONALLY LEFT BLANK

Hinges & Rod Ends	Free-play / Smooth Operation		
Component Skins	Deformation / Cracks / Signs of Wear / Corrosion		
Control Cable Links & Push / Pull Rods	Tension / Wear / Fatigue		
Control Stops	Security / Deformation / Alignment		
Rear Spar Doubler	Check for Gap		

Paperwork		Pass	Fail
Record Findings	Aircraft Log		
Record Inspection	Aircraft Log		
Record Maintenance	Aircraft Log		

Notes and explanation of discrepancies found:

End of inspection checklist

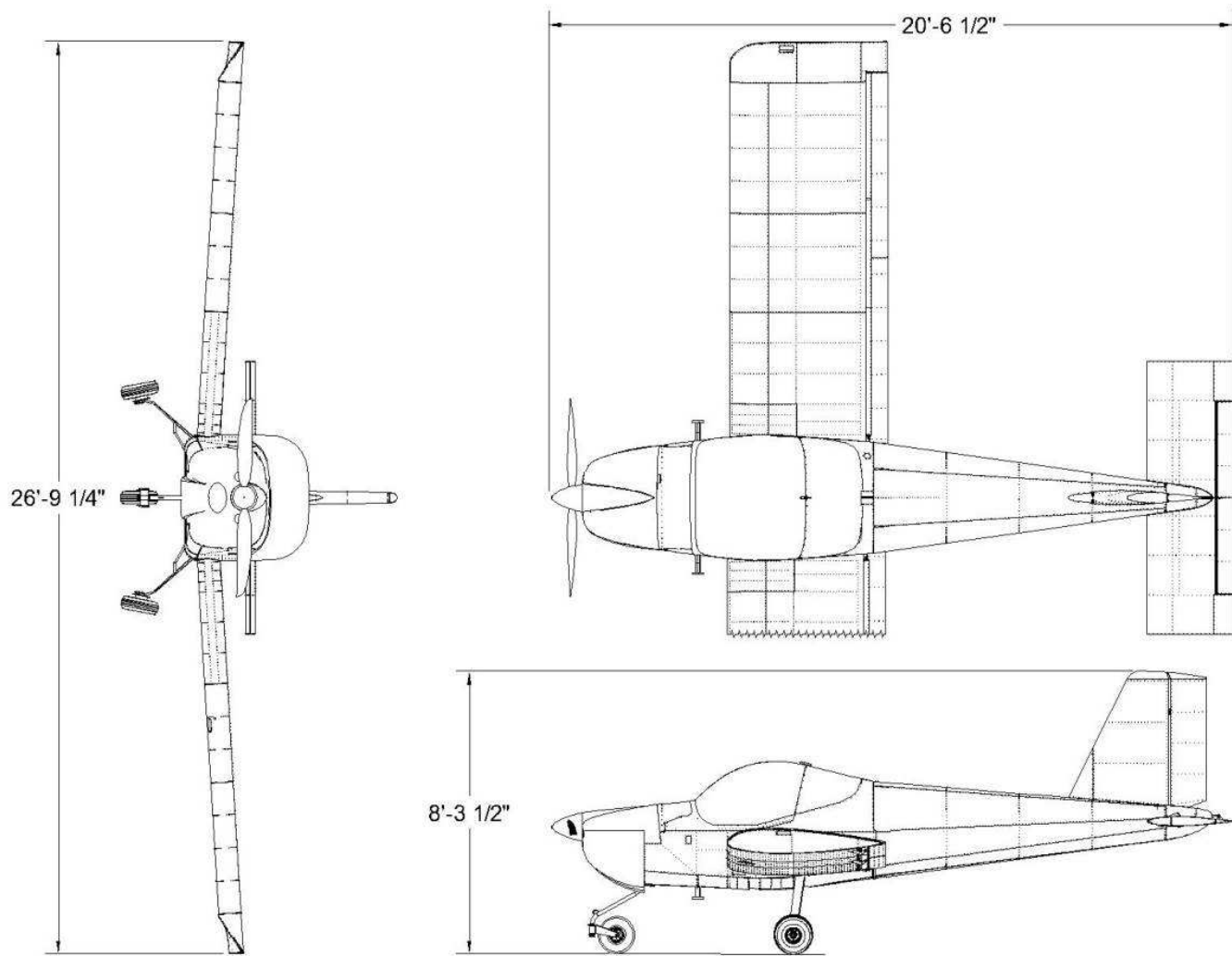
THIS PAGE INTENTIONALLY LEFT BLANK

ELECTRICAL SYSTEM SCHEMATICS

Refer to P. O. H. or
<http://www.vansaircraft.com/public/downloads.htm>

THIS PAGE INTENTIONALLY LEFT BLANK

3-VIEW



THIS PAGE INTENTIONALLY LEFT BLANK

Feedback Form

Owner:	Name	Phone:	Number	Aircraft:	Model
Contact:	Name	Phone:	Number	Total Time	Serial Number
Inspector:	Name	Phone:	Number	Engine:	Model
Inspection:	Date	Storage:	Inside/outside/etc	Total Time	Serial Number
Location:	City	State	Country		
Affected Parts:					
Problem Description:					

THIS PAGE INTENTIONALLY LEFT BLANK

CHAPTER 19 - GLOSSARY

100-hr Inspection	Comparable to an annual condition inspection, except that the interval of inspection is 100 hrs of operation instead of 12 calendar months. This inspection applies to LSA used for commercial operations such as flight instruction or rental, or both.
A&P technician	Airframe and power plant technician as defined in the U.S. by 14 CFR Part 65 or equivalent certification in other countries.
Approved Owner	Some aircraft maintenance may be performed by an "Approved Owner" found competent by Van's Aircraft. Approval will be for a specific task, person(s) and aircraft.
F39	Refers to the FAA Advisory Circular 'Acceptable Methods, Techniques, and Practices – Aircraft Inspection and Repair.
Adverse conditions	Includes, but not limited to, conditions that could cause build up of foreign matter or contamination or removal of lubrications, such as; extreme weather, and dirty, sandy or salty conditions, thorough plane washing, etc.
Annual Condition Inspection	Detailed inspection performed once a year on an LSA in accordance with instructions provided in the maintenance manual supplied with the aircraft and F39 Appendix D. The purpose of the inspection is to identify any wear, corrosion, or damage before it compromises the safe operation and airworthiness of the aircraft.
Anti-Servo/Trim tab	AST. The anti-servo/trim tab has two functions. It provides movement resistance (control force feed back), and also serves as a trim control surface. The trim function is controlled with the pitch-trim servo.
As needed	At first sign of wear or abnormal operation and/or following exposure to adverse conditions.
CFR 14	Code of Federal Regulations Title 14 Aeronautics and Space also known as the FAR's.
Check	To verify the correctness of, as by comparison to inspect or test the condition, performance, safety, etc., of
Electronic Flight Information System	EFIS. Refers to the Dynon D-180, Dynon Skyview or Garmin G3X. The unit receives signals from multiple sensors on the airframe and engine, then provides valuable engine and flight information based on the signals from the sensors.
Emergency Locating Transmitter	ELT. The electronic device unit that sends a distress signal when G loads exceed a critical value, or when activated manually.

Engine Management System	EMS. Refers to the Dynon D-180, Dynon Skyview or Garmin G3X. The portion of the EFIS unit that compiles and displays engine information.
Extreme conditions	Heavily contaminated air; dust, bugs, smoke, debris, ash, sand, etc. or adverse climatic conditions
Flaperon	A control surface that combines the aileron and flap functions into one component with both functions
Global Positioning System	GPS. A navigational system involving satellites and computers that can determine the latitude and longitude of a receiver on Earth.
Heavy Maintenance	Maintenance, inspection, repairs, or alteration that a manufacturer has designated to require special training, equipment, or facilities. Only a qualified person may perform heavy maintenance.
Kit Assembly Instructions	KAI. Refers to the original kit assembly instructions that are provided by the manufacturer to complete the assembly of a kit plane.
Line Maintenance	Any repair, maintenance, scheduled checks, servicing, inspections, or alterations not considered heavy maintenance by the manufacturer with instructions provided in the manufacturer's maintenance manual.
LSA Repairman Inspection	LSA-RI. U.S. FAA- certified repairman (light sport aircraft) with an inspection rating as defined by 14 CFR Part 65, authorized to perform the annual condition inspection on experimental light sport aircraft, or an equivalent rating issued by other civil aviation authorities. This requires a 16-hour course.
LSA Repairman Maintenance	LSA-RM. U.S. FAA-certified light sport aircraft technician with a maintenance rating as defined by 14 CFR Part 65. This certificate is authorization to perform line maintenance, inspections, and repairs on any LSA certified aircraft. The maintenance rating is category specific, I.E. Fixed wing, weight shift, lighter than air, etc.
Maintenance Manual(s)	Manual provided by an LSA manufacturer or supplier that specifies all maintenance, repairs, and alterations authorized by the manufacturer.
Major Repair, Alteration, or Maintenance	Only a qualified person may perform major repair, alteration, or maintenance tasks that are not included in this maintenance manual.
Manufacturer	Any entity engaged in the production of an LSA or component used on an LSA.
Minor Repair, Alteration, or Maintenance	Generally applies to repair, alteration, or maintenance covered by instructions provided in the maintenance manual(s) supplied to the consumer.

Overhaul	Maintenance, inspection, repair, or alterations that are only to be accomplished by the original manufacturer or a facility approved by the original manufacturer of the product.
Overhaul Facility	Facility specifically authorized by the aircraft or component manufacturer to overhaul the product originally produced by that manufacturer.
Pilot Operating Handbook	POH. The handbook provided with the aircraft that introduces the systems and features that are included in the RV-12. Includes air and ground operating procedures and defines performance and weight and balance information.
Preventative maintenance	Simple or minor preservation operations and the replacement of small standard parts not involving complex assembly operations
Special Light Sport Aircraft	S-LSA. Applies to the aircraft covered in this manual, provided it remains consistent with the manufacturers design specifications. Manufacturer design specifications are in accordance with ASTM standards; F2245 for airplanes.
Repair Facility or Repair Station	Facility specifically authorized by the aircraft or component manufacturer to repair the product originally produced by that manufacturer.
Sport Pilot Certified	SPC. A person who holds a current Sport Pilot Certificate. A certified sport pilot may perform preventative maintenance and approve for flight a private use S-LSA aircraft that they own or operate.
Stabilator	An aircraft control surface that combines the horizontal stabilizer and elevator into one fully movable component.

THIS PAGE INTENTIONALLY LEFT BLANK

CHAPTER 20 - INDEX

A

AOA (see Angle-Of-Attack)	
Abbreviations	1-6
Air filter	12-3
Oil.....	1-11
Inspection.....	3-9
Installation.....	12-7
Removal.....	12-7
Angle-Of-Attack Sys. Press. Check.....	3-12, 5-13
Anti-servo / trim tab	5-6, 5-7
Inspection.....	3-15
Lubrication	5-26
Avionics	9-1

B

Battery	8-5
Charging	8-14
Installation.....	8-5
Removal.....	8-5
Terminals	8-14
Bellcrank	
Bearing.....	6-8
Stops	3-6
Brake pedal	
Lubrication	7-4
Brake Shoe Lining	
Inspection.....	See Matco Manual
Replacement.....	7-6
Brake System.....	7-1
Drain	7-5
Flush	7-5
Substitute Parts.....	17-2

C

Canopy	5-3
Cleaning.....	1-11
Installation.....	5-14
Inspection.....	3-5
Latch Block	5-3, 5-23
Removal.....	5-14
Capacities.....	1-13
Carburetor Synchronization	12-7
Center Section	
Inspection.....	3-13
Cherry Rivet (see Rivet, Blind, ...)	
Cockpit	
Inspection.....	3-5

Control cable	
Replacement.....	6-6
Control Stops	3-6
Control system	6-1
Rod-End Lubrication	6-9
Coolant.....	See Engine
Cowl Hinge.....	12-2, 12-16
Cowling	
Installation.....	12-5
Removal.....	12-4
Cylinder Removal.....	12-18

D

Decorative paint	15-5
Dynon.....	9-2, 9-3, 9-4, 18-3

E

Electrical System.....	8-1
Schematic.....	see POH
Terminal Tab.....	8-10
Emergency Locator Transmitter	
Inspection.....	3-7
Empennage	5-6
Inspection.....	3-13
Engine	1-12, 12-3
Firing Order.....	12-3
Inspection.....	See Rotax Manual
Lubrication	
Coolant	12-6
Oil	1-13, 12-6
Operating limits.....	See Rotax Manual
Replacement.....	12-18
Specifications.....	See Rotax Manual
Equipment List	1-21
Exhaust System	14-1
Installation.....	14-3
Lubrication	14-4
Removal.....	14-3

F

Feedback.....	See Safety
Firewall Forward.....	12-1
Inspection.....	3-8
Flaperon	5-4
Lubrication	5-25
Fuel System	13-1
Draining.....	13-4
Fuel Tank	
Installation.....	13-6
Removal.....	13-5
Fuselage.....	5-2
Inspection.....	3-10

Lift and Support.....	1-16
Terminal Tab.....	8-14
Inspection	3-9
Fuselage Pins	5-3
Fuses.....	8-6

G

Garmin.....	9-2, 9-4
Gascolator	
Cleaning.....	13-7
Installation.....	13-7
Inspection.....	3-9
Removal.....	13-7

H

Harness, Shoulder	5-3
Inspection.....	3-5
Replacement.....	5-22
Heat.....	See Utilities
Hinge	
Cowl	12-16
Hinge	
Anti-Servo Tab	5-25
Flaperon.....	5-17
Rudder	5-18
Stabilator.....	5-19

I

Idle Setting	12-12
Inner tube	
Main	5-16
Nose.....	5-17
Inspection	3-1
Checklist	18-7

L

Landing Gear	5-8
Inspection.....	3-11
Lights.....	8-1
Lubricant.....	1-11
Lubrication.....	1-13

M

Main Landing Gear	
Bearings.....	5-27
Inspection.....	3-11
Installation.....	5-21
Removal.....	5-21
Main Wheel and Tire	
Inspection.....	3-11

Installation.....	5-15
Removal.....	5-15
Main Wheel Assembly	5-9
Master cylinder	
Installation.....	7-4
Removal.....	7-3

N

Nose Gear Leg Fairing.....	5-10
Nose Landing Gear	5-8
Inspection.....	3-11
Lubrication	5-26
Removal.....	5-21
Nose Wheel and Tire	
Bearings.....	5-26
Installation.....	5-16
Removal.....	5-16
Nose Wheel Assembly	5-9

O

Oil.....	See Engine
----------	------------

P

Paint	See Painting and coating
Painting and Coating.....	15-1
Panel Circuit Board	8-9
Piston Removal	12-18
Pitch-Trim Servo	
Replacement.....	8-7
Pitot & Static.....	9-3
Powder coat	
Repair	15-3
Primer	15-4
Propeller	11-1
Inspection.....	3-7, 11-3
Push/pull cable.....	10-2
Inspection.....	3-6, 3-9
Lubrication	10-5

R

Radio	
Inspection.....	3-7
Rear Spar	
Doubler Check	3-13
Doubler Replacement	5-23
Lubrication	5-23
Rivet	
Blind, Cherry Max Alternative	4-2
Inspection.....	3-10
Rod end	
Lubrication	6-9

Replacement.....	6-7
Rudder Pedals	
Installation.....	6-9
Removal.....	6-8
Rudder.....	5-7
Inspection.....	3-14
Removal.....	5-18
RV-12	
3-View	18-25
Summary.....	1-1

S

Safety	1-4
Feedback	17-1
Feedback Form.....	18-27
Sensenich.....	See Propeller
Service Schedule	2-1
Table	18-3
Snap bushing	8-13
Software	9-6
Spark Plug.....	12-3
Replacement.....	12-5
Stabilator	5-7
Control cable pulley	6-3
Inspection.....	3-15
Stub Spar	
Lubrication	5-23
Supplement	18-1
Substitute Parts.....	17-3

T

Throttle Cable Lead Hookup	12-10
Throttle Spring Replacement	12-15
Tire Assembly Balancing.....	5-29
Pressure.....	1-14
Torque	1-15
Troubleshooting	16-1

U

Units	1-7
Utilities.....	10-1
Heat	10-2
Ventilation	10-3
Vent door	10-5

V

Vacuum Gauge Hookup.....	12-11
Ventilation.....	See Utilities
Vertical Stabilizer	5-7
Inspection.....	3-13

W

Weight and Balance 1-18
Wheel Bearings
 Main 5-26
 Nose..... 5-25
Wing Attach Location Lubrication 5-25
 Fuselage Pins 5-25
 Stub Spar and Rear Spar 5-25